

Conductive Level Controller 61F-GPN-BT/-BC

CSM_61F-GPN-BT_BC_DS_E_2_1

Battery (24 VDC) allows use in locations without AC power supply. AC sine-wave voltage between electrodes enables stable detection with no electric corrosion.

- Outputs can be set to self-hold at ON or OFF using special circuits.
- Adjustable sensitivity, with an operating resistance range of 0 to 100 k Ω , allows use for a wide variety of liquids.
- Relay contact chattering conventionally caused by waves eliminated using open collector output, reducing contact wear.
- Meets CE marking and is a UL recognized component.



Refer to Safety Precautions for Floatless Level Controllers.

Features

The 61F can now run on DC power to allow energy savings, greater safety, and use in emergency situations.

Combines DC Power Supply with AC Sensing Method

AC sine-wave signals are sent to electrodes using a built-in DC-AC converter, preventing electric corrosion and ensuring safety.

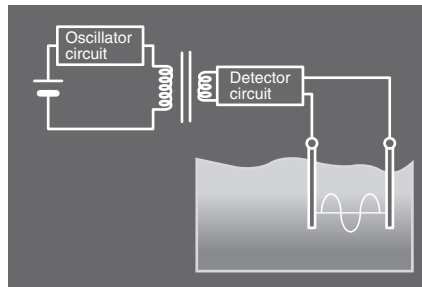

Open Collector Output

Signals can be used as direct input for a PLC. PNP output is also possible using the connection method.

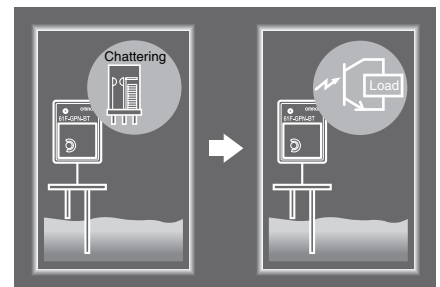

Supports Multi-channel Sensing

Power supply circuits and detection circuits are isolated, allowing more than one Controller to be used in the same tank.

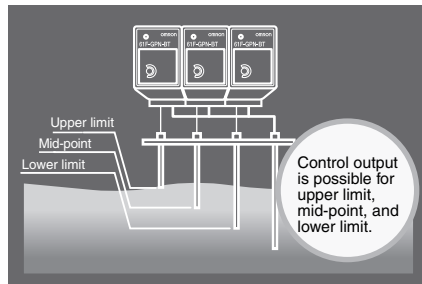

Same Wiring for Supply and Drainage

Supply control and drainage control can be performed with the same wiring (short terminals 7 and 8 for supply control). This makes it easy to perform wiring and confirm connection.

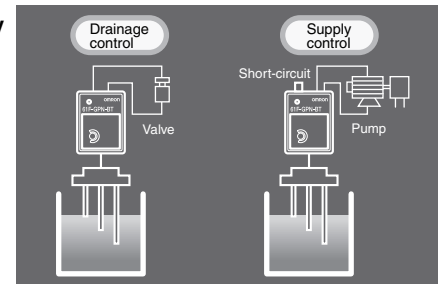

Ordering Information

Product name	Model number	
Conductive Level Controller	61F-GPN-BT 24VDC	61F-GPN-BC 24VDC
	Open collector (NPN)	Relay contact (SPST-NO)
Front Socket	PF113A-E	
Electrode Holder	(See note.)	

Note: A variety of Holders are available to suit different types of application. For details, refer to *61F Floatless Level Controller (F030-E1-8)*.

Specifications

■ Ratings

	61F-GPN-BT	61F-GPN-BC
Rated voltage	24 VDC	
Allowable voltage range	85% to 110% of the rated voltage	
Interelectrode voltage	5 VAC max.	
Operation resistance (See note 1.)	Variable (0 to 100 kΩ)	
Error	For scale of 0: +10 kΩ; For scale of 100: ±10 kΩ	
Release resistance	200% max. of the operation resistance	
Switching between supply and drainage	Terminals 7 and 8 open: Automatic drainage operation Terminals 7 and 8 shorted: Automatic supply operation	
Output specifications	Open collector (NPN) 30 VDC, 100 mA max. Leak current: 100 μA max.	Relay output, SPST-NO 5 A, 240 VAC (Resistive load) 5 A, 30 VDC
Life expectancy	---	Electrical: 100,000 operations min. Mechanical: 20,000,000 operations min.
Wiring distance (See note 2.)	100 m max.	

- Note:** 1. The 61F may not operate at resistance settings close to zero. Adjust the sensitivity to match actual usage conditions.
2. The figure for wiring distance above is for when 600-V 3-core cable with a cross-sectional area of 0.75 mm² is used.

■ Characteristics

Ambient operating temperature	-10 to 55°C
Ambient operating humidity	25% to 85%
Insulation resistance	100 MΩ min. (at 500 VDC)
Dielectric strength (See note.)	2,000 VAC, 50/60 Hz for 1 minute
Power consumption	2 W max.
Response time	Operating: 1.5 s max. Releasing: 3.0 s max.

Note: The dielectric strength is measured between power terminals and electrode terminals, power terminals and output terminals, and between electrode terminals and output terminals.

Connections

■ Automatic Drainage Operation

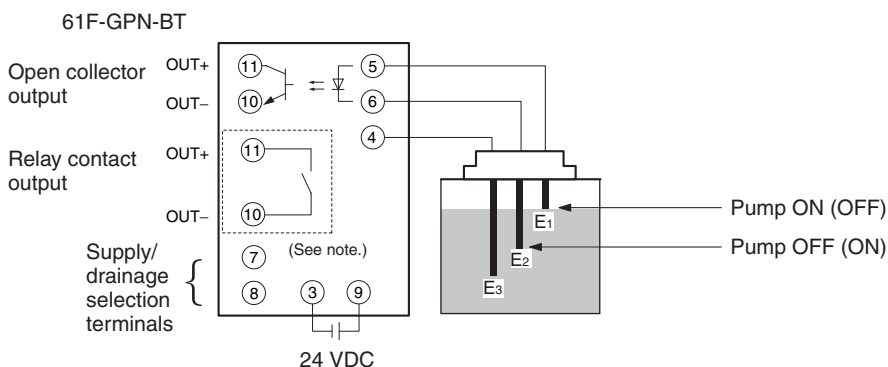

Note: [] The part within the dotted-line box is for the 61F-GPN-BC (relay-output type) only.

■ Automatic Water Supply Operation

Short terminals 7 and 8 for automatic water supply operation. (Operation shown in parentheses in the diagram above.)

■ Reading Signals for the Liquid Level Only (No Control)

Only E1 and E3 are used. Output will turn ON when the liquid level reaches E1 if terminals 7 and 8 are open, and will turn OFF if terminals 7 and 8 are closed. Also, to take signals for liquid level at several points, use terminal 4 as a common for all of the Controllers and use terminal 5 of each Controller as an electrode.

Note: If terminals 7 and 8 are shorted, operation of the 61F relay is “de-energizing” (i.e., energized normally and de-energized when liquid is present across the electrodes). Therefore, if the power supply connected across terminals 3 and 9 is interrupted, the output from terminals 10 and 11 will turn OFF, enabling detection of power interruptions.

Dimensions

61F-GPN-BT/-BC

Use a PFC-N8 Mounting Bracket to mount the Level Controller to a PF113A Rail-mounted Socket.

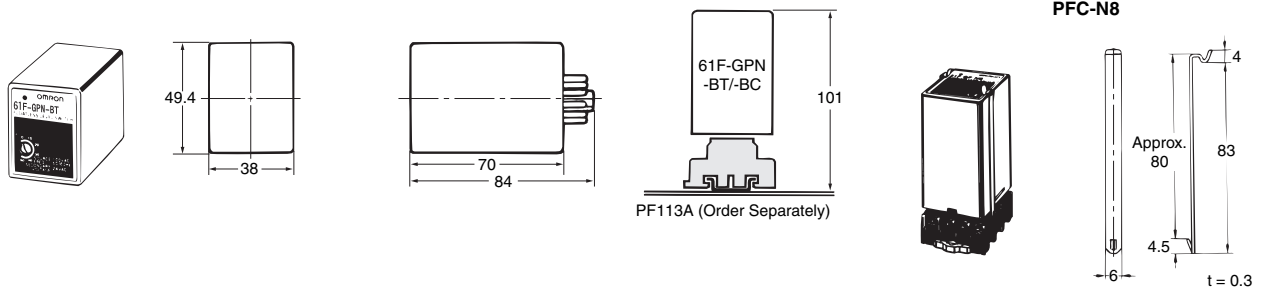

Note: PFC-N8 Mounting Bracket (provided with the Level Controller)

Application Examples

Applications

Drainage control for semiconductor wafer cleaning installations.

Meet safety standards by using DC power supply for all devices in a panel.

Liquid level control for waste-heat recovery boilers in co-generation systems.

Liquid level control for solar power generation systems.

Liquid level control for remote regions without AC power supply.

Cut costs by using the 61F in situations where ultrasonic/electrostatic capacity level controllers were used because only DC power supply was available.

Number of controllers required:
2
↓
1

Safety Precautions

Refer to *Safety Precautions for Floatless Level Controllers*.

General Precautions

Before using the Controller under conditions not described in the relevant documents or applying the Controller to nuclear control systems, railroad systems, aviation systems, vehicles, combustion systems, medical equipment, amusement machines, safety equipment and other systems, machines, and equipment that may have a serious influence on lives and property if used improperly, consult your OMRON representative.

Make sure that the ratings and performance characteristics of the Controller are sufficient for the systems, machines, and equipment and be sure to provide the systems, machines, and equipment with double safety-mechanisms.

Safety Precautions

In order to ensure safe operation, be sure to observe the following points.

- Use a power supply voltage within the specified range.
- Do not use the Controller in locations subject to flammable gases or objects.
- Insert the Socket until it securely clicks into place.
- Do not short the load connected to the output terminals.
- Do not connect the power supply in reverse.

Correct Use

Mounting

Mount to a panel of thickness 1 to 5 mm.

Do not mount the Controller in the following places.

- Locations subject to strong vibrations or shocks.
- Locations outside the specified temperature and humidity ranges, or locations prone to condensation. (The Controller detects high impedances. Do not use in locations subject to high humidity levels.)
- Locations subject to dust.
- Locations subject to corrosive gases (in particular, sulphurized gas or ammonia gas).
- Outdoors, or in locations subject to direct sunlight.
- Near devices that generate strong, high-frequency noise (e.g., high-frequency welders, machines).

ALL DIMENSIONS SHOWN ARE IN MILLIMETERS.

To convert millimeters into inches, multiply by 0.03937. To convert grams into ounces, multiply by 0.03527.

In the interest of product improvement, specifications are subject to change without notice.

Read and Understand This Catalog

Please read and understand this catalog before purchasing the products. Please consult your OMRON representative if you have any questions or comments.

Warranty and Limitations of Liability

WARRANTY

OMRON's exclusive warranty is that the products are free from defects in materials and workmanship for a period of one year (or other period if specified) from date of sale by OMRON.

OMRON MAKES NO WARRANTY OR REPRESENTATION, EXPRESS OR IMPLIED, REGARDING NON-INFRINGEMENT, MERCHANTABILITY, OR FITNESS FOR PARTICULAR PURPOSE OF THE PRODUCTS. ANY BUYER OR USER ACKNOWLEDGES THAT THE BUYER OR USER ALONE HAS DETERMINED THAT THE PRODUCTS WILL SUITABLY MEET THE REQUIREMENTS OF THEIR INTENDED USE. OMRON DISCLAIMS ALL OTHER WARRANTIES, EXPRESS OR IMPLIED.

LIMITATIONS OF LIABILITY

OMRON SHALL NOT BE RESPONSIBLE FOR SPECIAL, INDIRECT, OR CONSEQUENTIAL DAMAGES, LOSS OF PROFITS OR COMMERCIAL LOSS IN ANY WAY CONNECTED WITH THE PRODUCTS, WHETHER SUCH CLAIM IS BASED ON CONTRACT, WARRANTY, NEGLIGENCE, OR STRICT LIABILITY.

In no event shall the responsibility of OMRON for any act exceed the individual price of the product on which liability is asserted.

IN NO EVENT SHALL OMRON BE RESPONSIBLE FOR WARRANTY, REPAIR, OR OTHER CLAIMS REGARDING THE PRODUCTS UNLESS OMRON'S ANALYSIS CONFIRMS THAT THE PRODUCTS WERE PROPERLY HANDLED, STORED, INSTALLED, AND MAINTAINED AND NOT SUBJECT TO CONTAMINATION, ABUSE, MISUSE, OR INAPPROPRIATE MODIFICATION OR REPAIR.

Application Considerations

SUITABILITY FOR USE

OMRON shall not be responsible for conformity with any standards, codes, or regulations that apply to the combination of products in the customer's application or use of the products.

At the customer's request, OMRON will provide applicable third party certification documents identifying ratings and limitations of use that apply to the products. This information by itself is not sufficient for a complete determination of the suitability of the products in combination with the end product, machine, system, or other application or use.

The following are some examples of applications for which particular attention must be given. This is not intended to be an exhaustive list of all possible uses of the products, nor is it intended to imply that the uses listed may be suitable for the products:

- Outdoor use, uses involving potential chemical contamination or electrical interference, or conditions or uses not described in this catalog.
- Nuclear energy control systems, combustion systems, railroad systems, aviation systems, medical equipment, amusement machines, vehicles, safety equipment, and installations subject to separate industry or government regulations.
- Systems, machines, and equipment that could present a risk to life or property.

Please know and observe all prohibitions of use applicable to the products.

NEVER USE THE PRODUCTS FOR AN APPLICATION INVOLVING SERIOUS RISK TO LIFE OR PROPERTY WITHOUT ENSURING THAT THE SYSTEM AS A WHOLE HAS BEEN DESIGNED TO ADDRESS THE RISKS, AND THAT THE OMRON PRODUCTS ARE PROPERLY RATED AND INSTALLED FOR THE INTENDED USE WITHIN THE OVERALL EQUIPMENT OR SYSTEM.

PROGRAMMABLE PRODUCTS

OMRON shall not be responsible for the user's programming of a programmable product, or any consequence thereof.

Disclaimers

CHANGE IN SPECIFICATIONS

Product specifications and accessories may be changed at any time based on improvements and other reasons.

It is our practice to change model numbers when published ratings or features are changed, or when significant construction changes are made. However, some specifications of the products may be changed without any notice. When in doubt, special model numbers may be assigned to fix or establish key specifications for your application on your request. Please consult with your OMRON representative at any time to confirm actual specifications of purchased products.

DIMENSIONS AND WEIGHTS

Dimensions and weights are nominal and are not to be used for manufacturing purposes, even when tolerances are shown.

PERFORMANCE DATA

Performance data given in this catalog is provided as a guide for the user in determining suitability and does not constitute a warranty. It may represent the result of OMRON's test conditions, and the users must correlate it to actual application requirements. Actual performance is subject to the OMRON Warranty and Limitations of Liability.

ERRORS AND OMISSIONS

The information in this document has been carefully checked and is believed to be accurate; however, no responsibility is assumed for clerical, typographical, or proofreading errors, or omissions.

2008.12

In the interest of product improvement, specifications are subject to change without notice.

OMRON Corporation
Industrial Automation Company

<http://www.ia.omron.com/>

(c)Copyright OMRON Corporation 2008 All Right Reserved.