

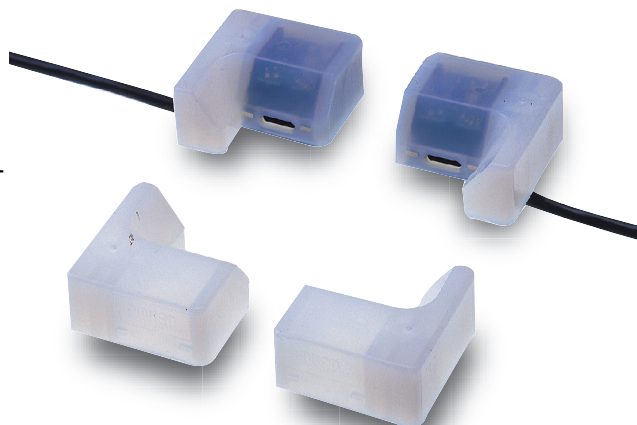

# EE-SPY801/802

## Photomicrosensors for detecting wafer-carrier mounting.

- The mounting position is set with a pedestal.
- The contact surface with the wafer carrier uses a special chemical-resistant fluororesin.
- The unique optical system enables stable detection of almost all wafer-carriers.
- Light modulation effectively reduces external light interference.
- Utilizes talc-free clean cables.





 Be sure to read *Safety Precautions* on page 3.

## Ordering Information

### Sensors

 Infrared light

Appearance	Sensing method	Sensing distance		Output configuration	Cable length	Model
	Reflective type	 0 to 3 mm		Turns ON when wafer carrier is present.	2 m	EE-SPY801 2M
						EE-SPY802 2M

### Accessories (Order Separately)







Item	Model
Pedestal	EE9-C01
	EE9-C02

Note: There are no sensor functions provided.

## Ratings and Specifications

Item	Models	EE- SPY801/802
Sensing distance (Standard sensing object)		0 to 5 mm (White paper: 15 × 15 mm <sup>2</sup> , reflection factor: 90%) 0 to 3 mm (Black paper: 15 × 15 mm <sup>2</sup> , reflection factor: 10%)
Sensing object		Transparent or opaque wafer carriers
Operation indicator		Lit orange when object is detected.
Light source		GaAs infrared LED with a peak wavelength of 940 nm
Supply voltage		12 to 24 VDC ±10%, ripple (p-p): 5% max.
Current consumption		30 mA max.
Control output		NPN open collector: Load power supply voltage: 5 to 24 VDC Load current: 100 mA max. OFF current: 0.5 mA max. 100 mA load current with a residual voltage of 0.8 V max. 40 mA load current with a residual voltage of 0.4 V max.
Response time		5 ms max.
Ambient illumination		3,000 lx max. with incandescent light or sunlight on the surface of the receiver
Ambient temperature range		Operating: -10 to +55°C Storage: -25 to +65°C (with no icing)
Ambient humidity range		Operating: 5% to 85% Storage: 5% to 95% (with no condensation)
Vibration resistance		Destruction: 1 to 500 Hz, 1.0-mm single amplitude or 150 m/s <sup>2</sup> each in X, Y, and Z directions 3 times and for 11 min. each
Shock resistance		Destruction: 500 m/s <sup>2</sup> for 3 times each in X, Y, and Z directions
Degree of protection		IEC IP30
Connecting method		Pre-wired (Standard length: 2 m)
Weight (packaged)		Sensor: Approx. 43 g; Accessory (Pedestal): Approx. 9 g
Material	Case	Ethylene tetrafluoro ethylene (ETFE)
	Base plate	Polybutylene phthalate (PBT)
Accessories		Instruction Manual

## I/O Circuit Diagrams

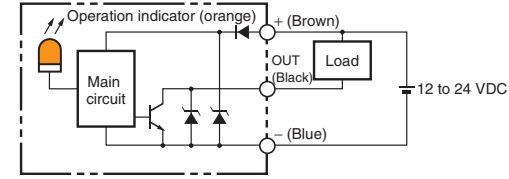
Model	Output configuration	Timing charts	Output circuit
EE-SPY801 EE-SPY802	Turns ON when wafer carrier is present.	<p>With wafer carrier</p>  <p>Without wafer carrier</p>  <p>Operation indicator (orange) ON</p>  <p>OFF</p>  <p>Output transistor ON</p>  <p>OFF</p>  <p>Load Operates</p> <p>(etc., relay) Releases</p>	

## Standard Usage

This sensor is designed to detect wafer-carrier mountings. The bottom of the wafer carrier has a ribbed construction for the leg section, as shown in the following diagram. The EE-SPY801/802 detects the wafer-carrier mounting using a reflective optical sensor that detects the leg section of the wafer-carrier.

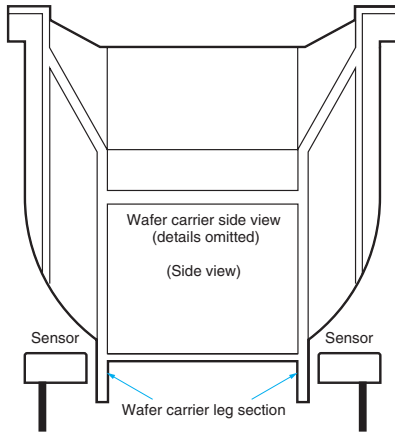

Install a Sensor (or Pedestal) at each of the four corners indicated by a circle in the following diagram.

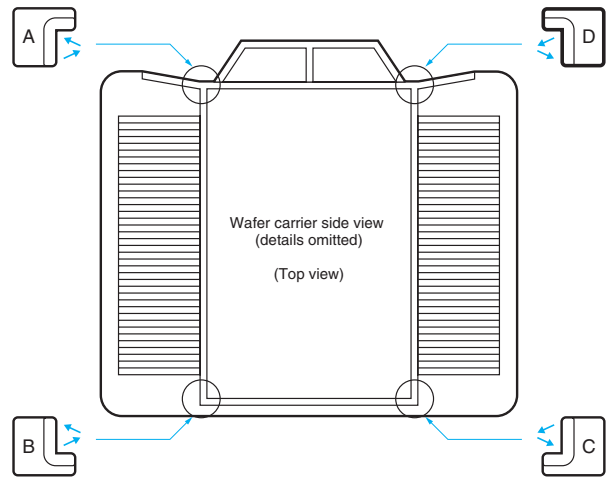

<b>A and C</b>	EE-SPY801 or EE9-C01
<b>B and D</b>	EE-SPY802 or EE9-C02

## Safety Precautions

Refer to *Warranty and Limitations of Liability*.

**⚠ WARNING**

This product is not designed or rated for ensuring safety of persons either directly or indirectly. Do not use it for such purposes.



**Precautions for Correct Use**

Make sure that this product is used within the rated ambient environment conditions.

● **Wiring**

When extending the cable, use an extension cable with conductors having a total cross-section area of 0.15 mm<sup>2</sup> (AWG26 equivalent). The total cable length must be 5 m maximum.

To use a cable length longer than 5 m, attach a capacitor with a capacitance of approximately 10 μF to the wires as shown below. The distance between the terminal and the capacitor must be within 5 m.

● **Mounting**

Mount the Photomicrosensors securely on a flat surface, and tighten the mounting screws using a tightening force of 0.30 N·m max. (Using a spring washer is recommended to prevent the screws from becoming loose.)

● **Adjustment**

The EE-SPY801/802 requires 10 ms to be in stable operation after power is supplied.

If separate power supplies are used for the EE-SPY801/802 and load, be sure to supply power to the EE-SPY801/802 before supplying power to the load.

● **Operating Environment**

Do not use the EE-SPY801/802 in locations subject to salty air or corrosive gases, such as hydrogen chloride gas.

## Dimensions

Tolerance class IT16 applies to dimensions in this datasheet unless otherwise specified.

### Sensors

#### EE-SPY801

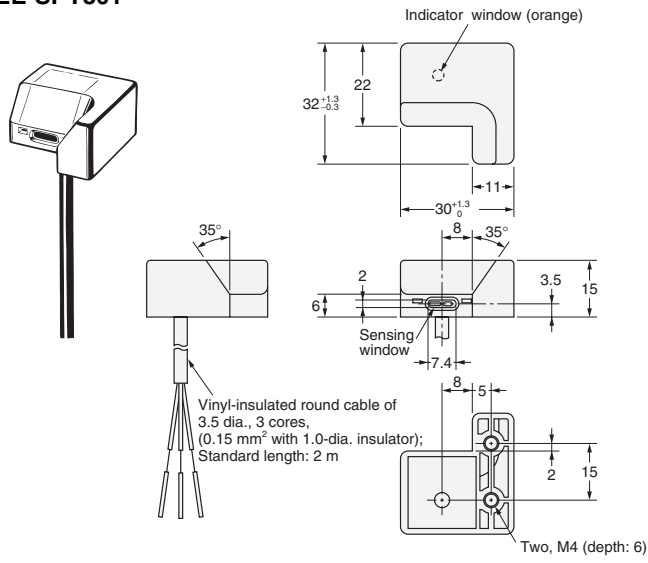

#### EE-SPY802

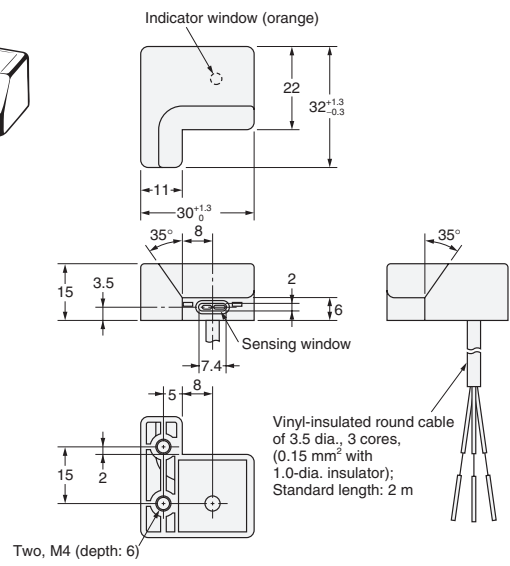

### Accessories (Order Separately)

#### Pedestal

##### EE9-C01

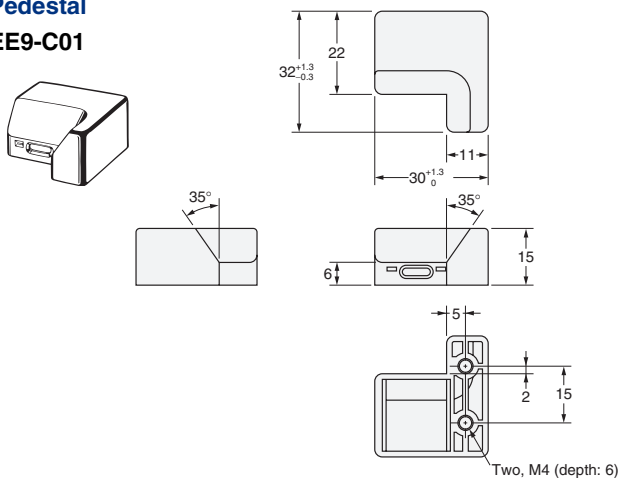

#### Pedestal

##### EE9-C02

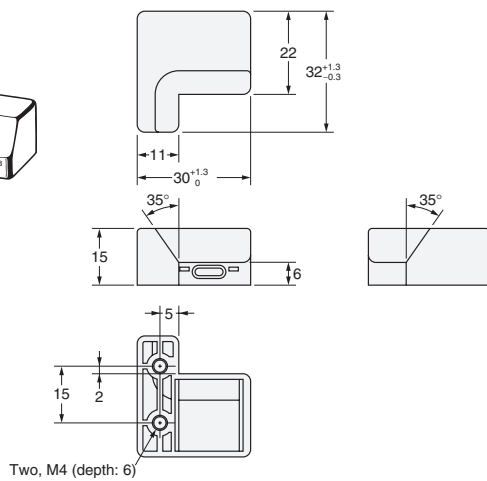

## Read and Understand This Catalog

Please read and understand this catalog before purchasing the products. Please consult your OMRON representative if you have any questions or comments.

## Warranty and Limitations of Liability

### WARRANTY

OMRON's exclusive warranty is that the products are free from defects in materials and workmanship for a period of one year (or other period if specified) from date of sale by OMRON.

OMRON MAKES NO WARRANTY OR REPRESENTATION, EXPRESS OR IMPLIED, REGARDING NON-INFRINGEMENT, MERCHANTABILITY, OR FITNESS FOR PARTICULAR PURPOSE OF THE PRODUCTS. ANY BUYER OR USER ACKNOWLEDGES THAT THE BUYER OR USER ALONE HAS DETERMINED THAT THE PRODUCTS WILL SUITABLY MEET THE REQUIREMENTS OF THEIR INTENDED USE. OMRON DISCLAIMS ALL OTHER WARRANTIES, EXPRESS OR IMPLIED.

### LIMITATIONS OF LIABILITY

OMRON SHALL NOT BE RESPONSIBLE FOR SPECIAL, INDIRECT, OR CONSEQUENTIAL DAMAGES, LOSS OF PROFITS OR COMMERCIAL LOSS IN ANY WAY CONNECTED WITH THE PRODUCTS, WHETHER SUCH CLAIM IS BASED ON CONTRACT, WARRANTY, NEGLIGENCE, OR STRICT LIABILITY.

In no event shall the responsibility of OMRON for any act exceed the individual price of the product on which liability is asserted.

IN NO EVENT SHALL OMRON BE RESPONSIBLE FOR WARRANTY, REPAIR, OR OTHER CLAIMS REGARDING THE PRODUCTS UNLESS OMRON'S ANALYSIS CONFIRMS THAT THE PRODUCTS WERE PROPERLY HANDLED, STORED, INSTALLED, AND MAINTAINED AND NOT SUBJECT TO CONTAMINATION, ABUSE, MISUSE, OR INAPPROPRIATE MODIFICATION OR REPAIR.

## Application Considerations

### SUITABILITY FOR USE

OMRON shall not be responsible for conformity with any standards, codes, or regulations that apply to the combination of products in the customer's application or use of the products.

At the customer's request, OMRON will provide applicable third party certification documents identifying ratings and limitations of use that apply to the products. This information by itself is not sufficient for a complete determination of the suitability of the products in combination with the end product, machine, system, or other application or use.

The following are some examples of applications for which particular attention must be given. This is not intended to be an exhaustive list of all possible uses of the products, nor is it intended to imply that the uses listed may be suitable for the products:

- Outdoor use, uses involving potential chemical contamination or electrical interference, or conditions or uses not described in this catalog.
- Nuclear energy control systems, combustion systems, railroad systems, aviation systems, medical equipment, amusement machines, vehicles, safety equipment, and installations subject to separate industry or government regulations.
- Systems, machines, and equipment that could present a risk to life or property.

Please know and observe all prohibitions of use applicable to the products.

NEVER USE THE PRODUCTS FOR AN APPLICATION INVOLVING SERIOUS RISK TO LIFE OR PROPERTY WITHOUT ENSURING THAT THE SYSTEM AS A WHOLE HAS BEEN DESIGNED TO ADDRESS THE RISKS, AND THAT THE OMRON PRODUCTS ARE PROPERLY RATED AND INSTALLED FOR THE INTENDED USE WITHIN THE OVERALL EQUIPMENT OR SYSTEM.

### PROGRAMMABLE PRODUCTS

OMRON shall not be responsible for the user's programming of a programmable product, or any consequence thereof.

## Disclaimers

### CHANGE IN SPECIFICATIONS

Product specifications and accessories may be changed at any time based on improvements and other reasons.

It is our practice to change model numbers when published ratings or features are changed, or when significant construction changes are made. However, some specifications of the products may be changed without any notice. When in doubt, special model numbers may be assigned to fix or establish key specifications for your application on your request. Please consult with your OMRON representative at any time to confirm actual specifications of purchased products.

### DIMENSIONS AND WEIGHTS

Dimensions and weights are nominal and are not to be used for manufacturing purposes, even when tolerances are shown.

### PERFORMANCE DATA

Performance data given in this catalog is provided as a guide for the user in determining suitability and does not constitute a warranty. It may represent the result of OMRON's test conditions, and the users must correlate it to actual application requirements. Actual performance is subject to the OMRON Warranty and Limitations of Liability.

### ERRORS AND OMISSIONS

The information in this document has been carefully checked and is believed to be accurate; however, no responsibility is assumed for clerical, typographical, or proofreading errors, or omissions.

2008.11

In the interest of product improvement, specifications are subject to change without notice.

**OMRON Corporation**  
Industrial Automation Company

<http://www.ia.omron.com/>

(c)Copyright OMRON Corporation 2008 All Right Reserved.