

Overview of Timers

■ What is a Timer?

A timer is a control device that outputs a signal at a preset time after an input signal is received.

Timer Mechanisms

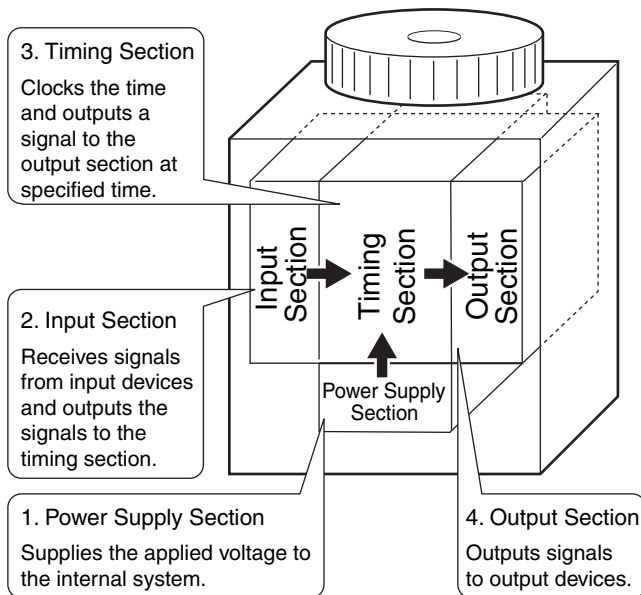

■ Settings and Indicators

Example for the H3CR-A

Settings

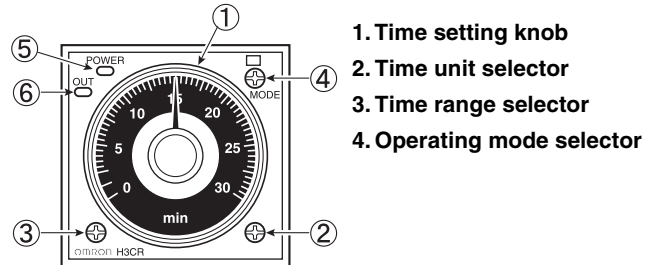

Note A variety of time ranges can be set with the H3CR-A using the time unit selector and time range selector.

Indicators

The pointers on the timer do not move along with time as the hands of a clock do. Time progression cannot be discerned. Therefore, two operation indicators are provided on the upper left of the timer to identify the timer status.

5. Run/Power Indicator (Green)

Run indicator: Indicates whether the time is being clocked or the time has been reached.

Power indicator: Indicates whether power is being supplied to the timer.

Fundamentally, the indicator will be lit when the power is being supplied and will flash when the time is being counted.

6. Output Indicator (Orange)

Used to see the status of the output. Lit when a signal is output.

■ Operating Modes

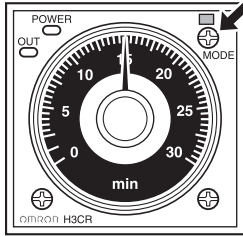

The operating mode selector is in the upper-left corner on the H3CR-A.

The operating mode determines the output method to use when the set time has been reached.

The following four basic operating modes are the most commonly used.

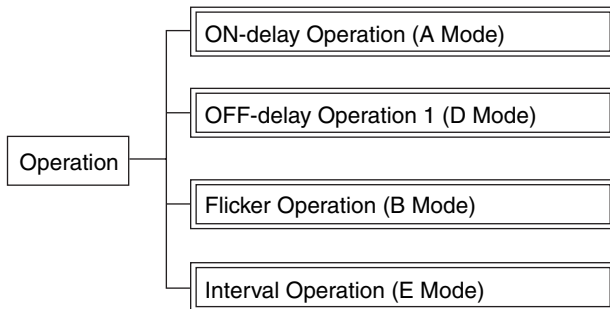

ON-delay Operation

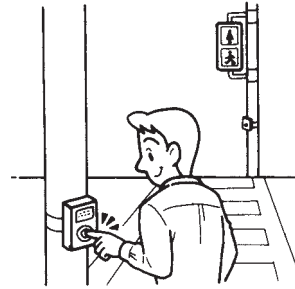

A traffic signal equipped with a pedestrian push button turns green after a delay when the button is pressed.

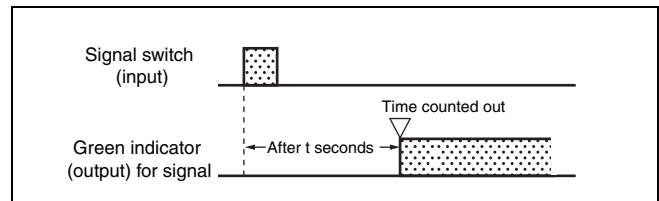

An operation in which a timer receives an input and then the output signal is output by the switching of the timer contacts after a set time delay is called "ON-delay operation."

This name is used because there is a delay between when the input signal is received (i.e., turns ON) and when the output signal is output.

ON-delay operation is the operating mode most often used for automated machines.

OFF-delay Operation



When you get in your car, the ceiling light turns ON when the door is opened. The light remains lit for several seconds after you get into the car and close the door. The light remains lit to avoid the inconvenience of having to search for the car keys in the dark.

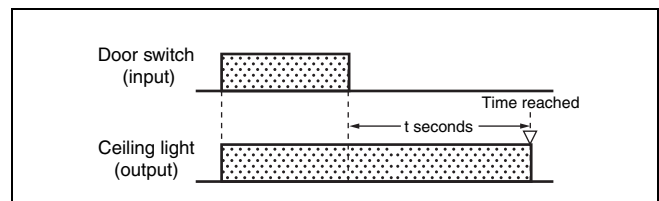

The ceiling light turns ON at the same time the door switch turns ON by opening the door. The light remains lit even when the door switch is turned OFF by closing the door. In other words, the ceiling light turns OFF after a set time delay. This type of operation, in which the output turns ON at the same time as the input and then the output turns OFF when the timer contacts switch after the set time has expired (with the set time being calculated from when the input turns OFF) is called "OFF-delay operation."

This name is used because there is a delay between when the input turns OFF and when the output turns OFF.

Flicker Operation

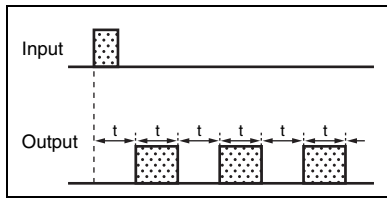

An operation in which an output repeatedly turns ON and OFF once an input is received (as shown in the time chart at the left) is called "flicker operation."

Application

Automatic Control of Fountains

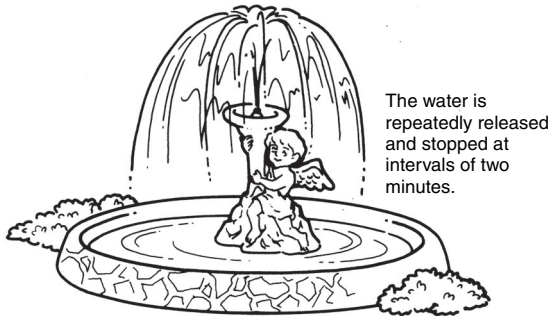

The water is repeatedly released and stopped at intervals of two minutes.

Interval Operation

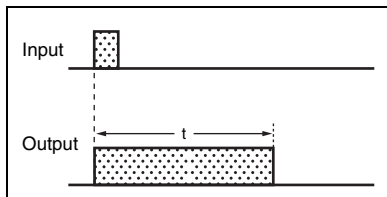

An operation in which the input and output turn ON at the same time and the output turns OFF after a set time (as shown in the time chart at the left) is called "interval operation."

Applications

Amusement Park Rides



The ride operates for five minutes when 100 yen is inserted.

Timer Starting Methods

There are two starting methods for the operating modes.

Example: ON-delay Operation

Signal ON-delay operation: The time clocking starts when the input section receives an input while voltage is being applied to the timer power supply section.

Power ON-delay operation: The time clocking starts when voltage is applied to the timer power supply section.

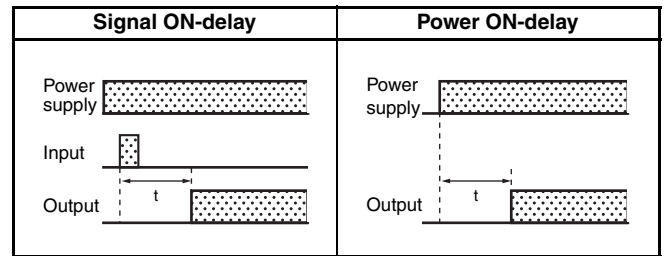

Differences between Signal ON-delay Operation and Power ON-delay Operation

1. **Accuracy (See note.):** Operation will not be stable unless a brief period elapses after the power supply is turned ON to the timing section of the timer.

Power supply start: Operation is unstable because the time clocking starts at the same time that the power supply turns ON. Therefore, deviation will occur in the operation time immediately after starting the Timer.

Signal start: Stable time accuracy is ensured because voltage is applied to the timer before starting the Timer.

The accuracy of the signal start is generally considered better. For some models, however, such as the H3CR, there is no change in accuracy.

Note: Accuracy is the correctness of the time.

2. Terminal Arrangement

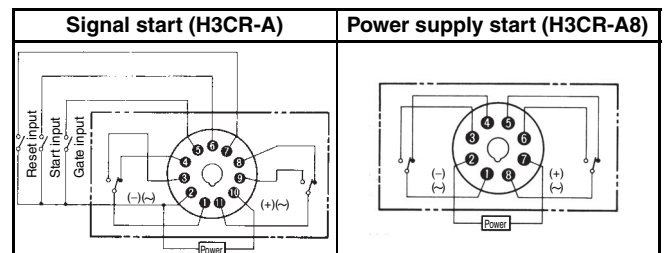

- Models with a signal start require three external inputs, so they have many terminals.
- Models with a power supply start (H3CR-A8) are the H3CR Timers most often used for automated machines.