

## Introduction

### What Is a Digital Panel Indicator?

A Digital Panel Indicator digitally processes measurement data, such as an analog signal from a linear sensor (including a voltage and current), or a pulse signal. It then converts and displays the data.

They can also act as interfaces (see note) by performing operations such as comparisons with user-set values, and transmitting data to computers and PLCs.

OMRON Digital Panel Indicators have good visibility in the field, are easy to use, are waterproof, and conform to international standards. Communications with host computers or programmable controllers have been improved to provide functionality for advanced information systems, such as data collection to increase operating rates and data recording capabilities to provide for implementing measures for PL laws and ISO.

**Note:** An interface is the boundary between two devices.

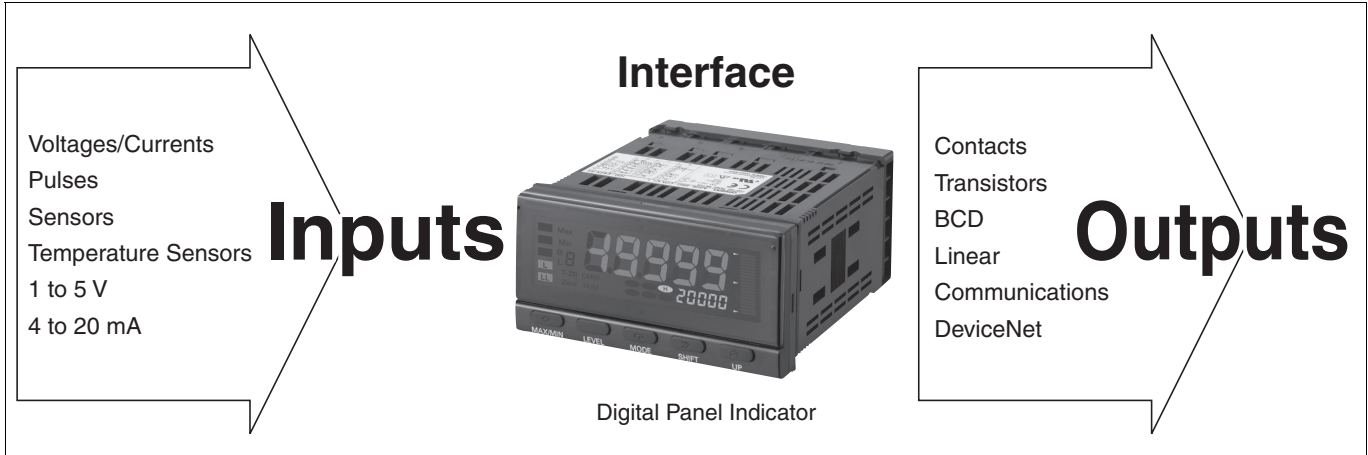

### Analog Signals

An analog signal is a signal that changes continuously.

- Types: 4 to 20 mA DC  
 1 to 5 VDC  
 0 to 5 VDC  
 0 to 10 VDC  
 etc.

#### A Wide Range of Voltages/Currents

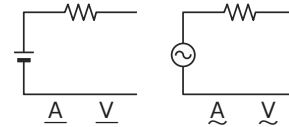

#### Infrared Thermosensors



#### Proximity Sensor or Rotary Encoder

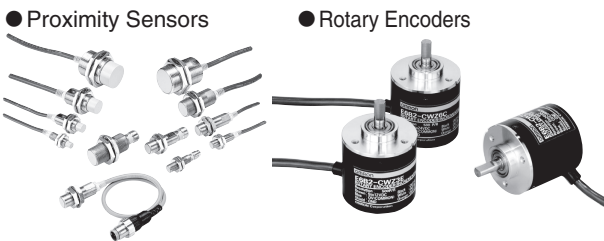

#### Displacement, Length Measurement, or Linear Output Sensors

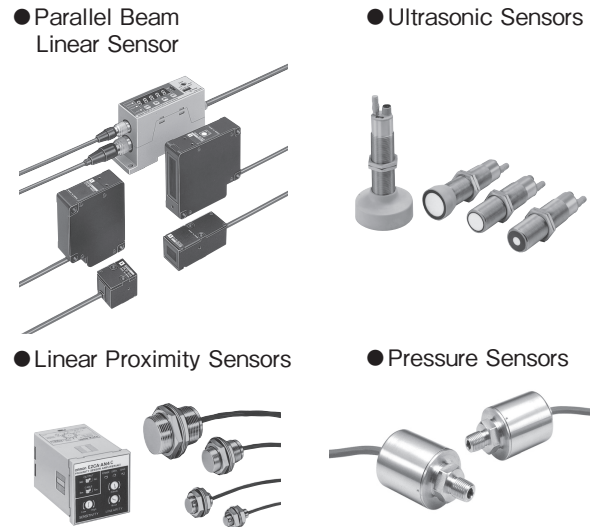

## Measurement Methods

An input signal that is within the measurement range of the Digital Panel Indicator can be directly connected to the input terminals. The following methods can be used to measure signals that exceed the measurement ranges.

### Measuring High DC Currents

A shunt resistor can be used in the input section to convert a DC current to a DC voltage to measure a high DC voltage.

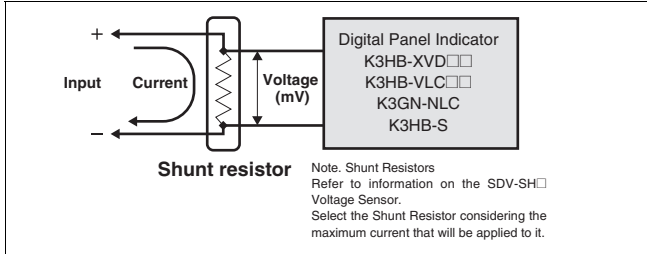

### Measuring DC voltages

Install an external voltage dividing circuit to divide the voltage for measurement.

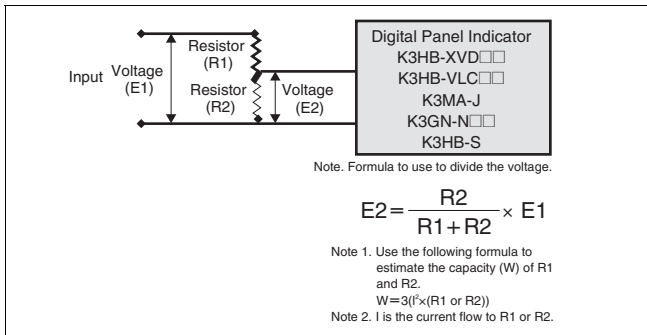

## Main Functions

### Scaling

Scaling is a function that converts the signal output from various sensors into physical measurement units (pressure, level, flow, etc.) before displaying it.

There are two scaling methods, one of which sets two points: any input value and its corresponding converted value. The other method is teaching by actual inputs.

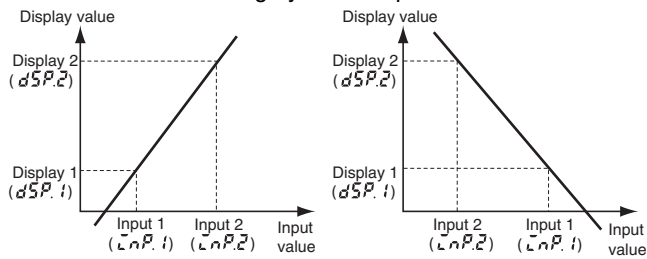

### Position Meter

The present measurement value is displayed as a position in relation to the scaling width on a 20-gradation position meter.

### Average Processing

Average processing of input signals with extreme variations eliminates flicker in the display and reduces the effect of noise in the input signal.

There are two types of averages that can be used, the simple average and the moving average.

### Measuring High AC Currents

Install an external current transformer (CT) to reduce the current flow for measurement.

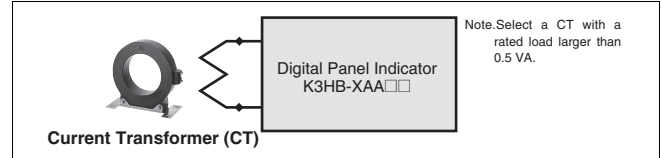

### Measuring High AC Voltages

Install an external power transformer (PT) to reduce the voltage for measurement.

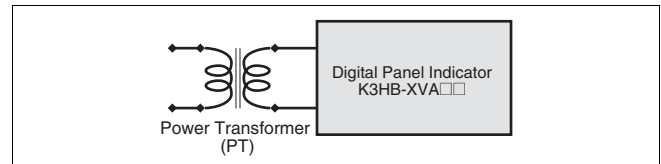

## Main Functions

### Forced Zero

It is possible to shift the present value to zero by selecting zero from the front-panel keys. It is useful for setting reference values for measurement.

#### Timing Chart of a Forced Zero

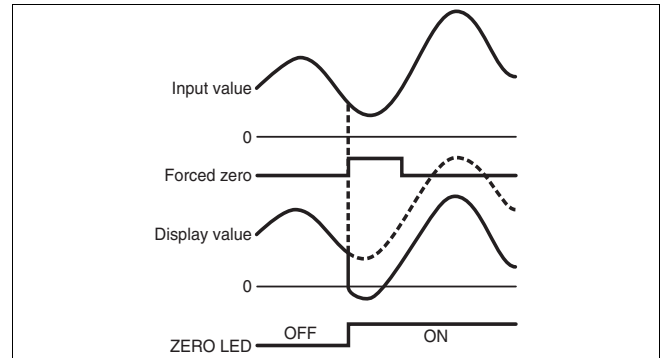

### Timing Hold

Prompted by an external timing signal, it can simultaneously measure the maximum value, minimum value, and the difference between maximum and minimum values.

### Maximum/Minimum Hold

Holds the maximum and minimum measurement values.

### Display Color Selection

The color of the PV display can be set to either green or red. It is also possible to set the current value to change color according to the status of the comparative output.

### Bank Selection

It is possible to switch between eight comparative value banks using the keys on the front-panel or external inputs.

## Settings and Displays

### Example Using the K3HB-X

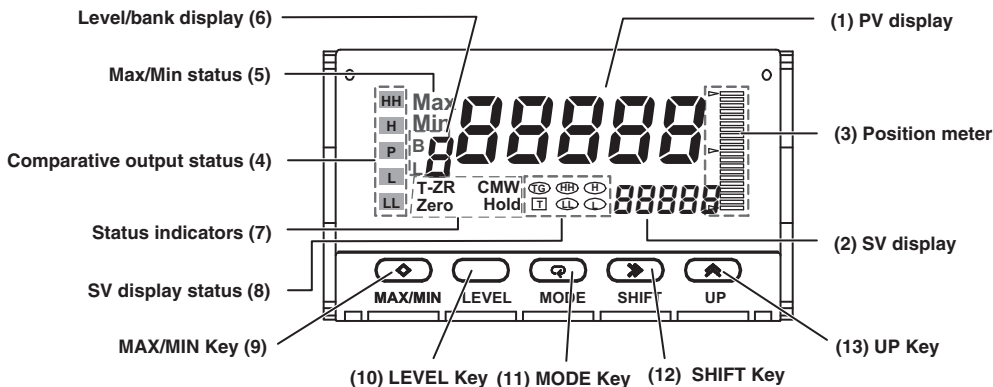

No.	Name	Function
(1)	PV display	Displays PVs, maximum values, minimum values, parameter names, and error names.
(2)	SV display	Displays SVs and monitor values.
(3)	Position meter	Displays the position of the PV with respect to a desired scale.
(4)	Comparative output status indicators	Display the status of comparative outputs.
(5)	Max/Min status indicator	Turns ON when the maximum value or minimum value is displayed in the RUN level.
(6)	Level/bank display	In RUN level, displays the bank if the bank function is ON. (Turns OFF if the bank function is OFF.) In other levels, displays the current level.
(7)	Status indicators	T-ZR: Turns ON when the tare zero function is executed. Turns OFF if it is not executed or is cleared. Zero: Turns ON when the forced-zero function is executed. Turns OFF if it is not executed or is cleared. Hold: Turns ON/OFF when hold input turns ON/OFF.

No.	Name	Function
(8)	SV display status indicators	TG: Turns ON when the timing signal turns ON. Otherwise OFF. T: Turns ON when parameters for which teaching can be performed are displayed. HH, H, L, LL: In RUN level, turn ON when the comparative set values HH, H, L, and LL are displayed.
(9)	MAX/MIN Key	Used to switch the display between the PV, maximum value, and minimum value and to reset the maximum and minimum values.
(10)	LEVEL Key	Used to switch level.
(11)	MODE Key	Used to switch the parameters displayed.
(12)	SHIFT Key	Used to change parameter settings. When changing a set value, this key is used to move along the digits.
(13)	UP Key	When changing a set value, this key is used to change the actual value. When a measurement value is displayed, this key is used to execute or clear the forced-zero function or to execute teaching.

## Configuration Examples

### Up/Down Counting Pulse Indicator K3HB-C Application Example

Counting the number of people entering an area

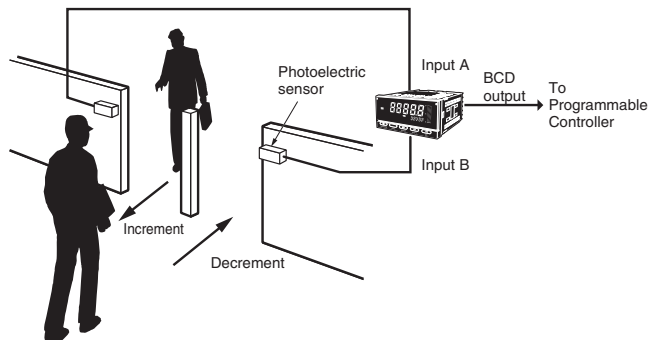

### Rotary Pulse Indicator K3HB-R Application Examples

Measuring roller winding speed

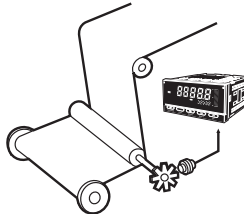

Measuring motor speed (for product testing)

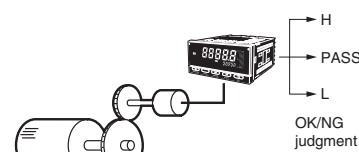

### Timer Interval Indicator K3HB-P Application Example

Measuring workpiece passing speed between A and B

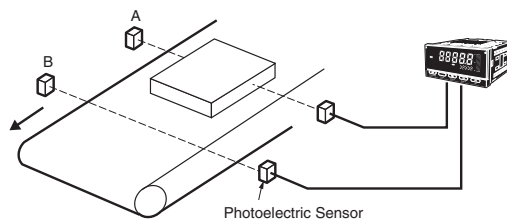

Sensors  
Switches  
Safety Components  
Relays  
Control Components  
Automation Systems  
Motion / Drives  
Energy Conservation Support / Environment Measure Equipment  
Power Supplies / In Addition  
Others  
Common

## Explanation of Terms

### **RS-232C (Recommended Standard 232C)**

RS-232C is a modem interface standard for serial communications defined by the Electronic Industries Alliance (EIA). It defines the electrical specifications, type, and function of the signal line, as well as the mechanical characteristics.

### **RS-422 and RS-485 (Recommended Standard 422 and 485)**

Both RS-422 and RS-485 are standards that specify the electrical characteristics of a balanced differential interface between drivers and receivers defined by the EIA, both are similar in many aspects.

RS-422 allows multiple signal receivers to connect to one driver (signal sender) on the same bus. It does not consider multiple drivers. RS-485 is an extension to RS-422, permitting multiple drivers with tri-state output, and allowing for a multi-drop (party line) structure.

It is possible to transmit at a higher speed with an RS-485 compared to the RS-232C standard, which is suitable only for transmission below 20 kbits/s.

### **RFI (Radio Frequency Interference)**

The effect from external electromagnetic fields. A type of EMI (Electromagnetic Interference).

### **Isolation**

DC isolation of the input and output signals of a device. For example, when using a thermocouple to measure the temperature within an electric oven, isolation is used to obtain accurate measurements.

### **Analog Signal**

A signal with a continuous amplitude.

### **Annunciator**

A process monitoring system whereby indicators are installed on the panel and control console to represent different stages of the process. If an error occurs, the corresponding indicator lights and an alarm sounds to provide notification of the error.

### **EMI (Electromagnetic Interference)**

The effect of external electromagnetic fields on device circuits and parts.

### **Impedance**

Refer to *Output Impedance* and *Input Impedance*.

### **SSR (Solid State Relay)**

Also called a non-contact relay, a solid state relay is an electronic switch that works without any moving parts. The most common is a photo-triac.

### **Response**

Refer to *Frequency Response* and *Step Response*.

### **Response Time**

For a step response, the response time is the time taken for a target value, display value, or an output signal to settle within a specified range of the final value.

(For DC output devices, it often means the time taken for the signal get from 0% to 90%.)

### **Temperature Coefficient**

For the ambient operating temperature of a device, the amount of temperature change due to the ambient temperature deviating from the reference temperature causes changes in the physical properties of the device. The temperature coefficient is the relative change of a physical property when the temperature is changed. (Often indicated as a percentage of the span per unit of temperature.)

### **Cascade Control**

Cascade control is a feedback control system that uses the output of one controller to manipulate the set point of other controllers.

### **Accuracy**

When using an OMRON signal generator and measurement device to take measurements under normal operating conditions, accuracy is defined as the difference between the ideal output and the actual output expressed as a percentage of the output span.

### **Allowable Load Resistance**

The range of load resistance values for which performance is given.

### **Common Mode Rejection Ratio**

Describes how well an instrument can reject the effect of common-mode voltage entering on the input from the output. It is usually expressed in decibels (dB). It is the ratio between the common-mode voltage on the input terminals of the device and the differential input signals required to achieve the same characteristics in the output signal.

### **Common Mode Voltage**

Noise voltage caused by external induction appears at the two input terminals. It has the same amplitude and phase at both input terminals. The common-mode voltage is the algebraic average of the instantaneous values of the two voltages.

### **Error**

The difference between measured value, set value, or rated value, and the measured or supplied true value.

### **Repeatability/Reproducibility**

The extent to which the measurements of the same item under the same conditions match when any or all of the following are changed; the person who is taking the measurements, the measuring device, the location, or time. (The degree of repeatability is usually expressed as a percentage of the span.)

### **Difference Input**

The difference between two input terminals when a common-mode voltage is applied to both terminals.

### **Cyclic Redundancy Check (CRC)**

A type of block check for data transmission. It is a popular error checking method as it is simple to implement and has an excellent error detecting ability.

### **Root-Mean-Square Value**

The square root of the mean of the squares of the instantaneous values of AC current or voltage. Also called RMS value.

### **Time Constant**

For a first-order linear time-invariant system, the time constant is the time taken for the step response to reach about 63% of its final value.

## **Frequency Response**

The change in gain and phase of the steady-state output as a response to the input frequency of a sinusoidal wave.

## **Output Impedance**

Impedance of an active device seen from its output terminals. Like input impedance, it can also be called output resistance.

## **Output Bias**

Output value when the product is idle (i.e., when the input is at the minimum value or there is no input).  
For example, if the output is 1 to 5 V, 1 V is the output bias. If the output is 0 to 5 V, 0 V is the output bias.

## **Signal**

Refer to *Analog Signal* and *Digital Signal*.

## **Step Response**

Response of a system to an instantaneous change in input from one constant value to another.

## **Span**

Difference between the maximum and minimum values of a range.

For example, if the range is  $-15$  to  $100^{\circ}\text{C}$ , the span is  $115^{\circ}\text{C}$ .

## **Split Control**

Controlling two or more different elements with one control signal.

For example, for a system that controls hot water temperature with separate control valves for hot and cold water, if both valve position motors are set at 0% to 50%, the hot water valve is controlled open at 100% to 0% but the cold water valve remains at 0%. If the setting is at 50% to 100%, the hot water valve remains at 0% and the cold water valve is controlled open at 0% to 100%.

## **Control**

Refer to *Cascade Control*, *Split Control*, and *PID Control*.

## **Insulation Resistance**

The electrical resistance between two conductors separated by insulating material. The electrical resistance between inputs, outputs, and power source circuits is often of concern for electrical measurements.

## **Zero Elevation**

Shifting the measurement range to the positive direction is called zero elevation.

For example, if the measurement range is  $-25$  to  $+100^{\circ}\text{C}$ , zero elevation is  $25^{\circ}\text{C}$ .

## **Zero Suppression**

Shifting the measurement range to the negative direction is called zero suppression.

For example, if the measurement range is 0.2 to 1.0  $\text{kgf/cm}^2$ , the zero suppression is 0.2  $\text{kgf/cm}^2$ .

## **Zero Bias**

Zero-suppression and zero-elevation together is called zero bias. (Generally it means that the bias is zero.)

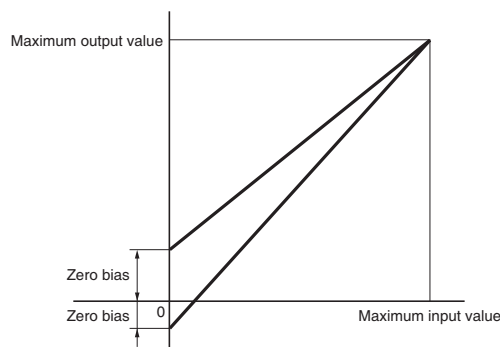

## **Resistance Temperature Sensor**

A temperature sensor that uses a resistor element which varies in resistance depending on the temperature. The resistor element may be made from platinum, nickel, or bronze. The platinum type is common used for measurements in the temperature range between  $-200$  and  $650^{\circ}\text{C}$ . In addition to the two-wire configuration, there are three-wire and four-wire configurations to compensate the lead-wire resistances. The three-wire configuration has one line connected to one end of the resistor and two on the other, and the four-wire configuration has two lines connected on either terminals of the resistor.

## **Time Sharing**

A technique used to run two or more processes concurrently with one processor by alternating the run time.

## **Dielectric Strength/Withstand Voltage**

The amount of voltage the insulation of an electrical device can withstand in a fixed period of time.

## **Neutral Zone**

The area between the two set points of a three-position switch.

## **Linearity**

The degree of deviation from a linear relationship between input and output signals. (The degree of linearity is generally indicated as a percentage of the span.)

## **Digital Signal**

Signals that express numbers in a discrete state.

## **Electric Power**

The amount of work done by electricity in one unit of time. In other words, the amount of electrical energy consumed in one unit of time.

Refer to *Reactive Power*, *Apparent Power*, and *Active Power*.

## **Input**

Refer to *Differential Input* and *Floating Input*.

## **Input Impedance**

Impedance of an active device seen from its input terminals. Often indicated by the equivalent impedance of the parallel resistance and capacitance. For DC measuring devices it is simply called input resistance.



## Thermocouple

A thermocouple is a type of temperature sensor that uses two conductors of different metals that generate a voltage across its junction due to the thermoelectric effect. The potential difference across the junction corresponds to the temperature at the measuring junction (thermocouple junction) compared to the temperature at the reference junction (also known as the cold junction), which is held at a constant temperature (e.g., 0°C). The potential difference depends on the type of metals used in addition to the difference in temperatures at the junctions. Common types of thermocouples are R (platinum/platinum rhodium), K (chromel/alumel), E (chromel/constantan), and T (copper/constantan).

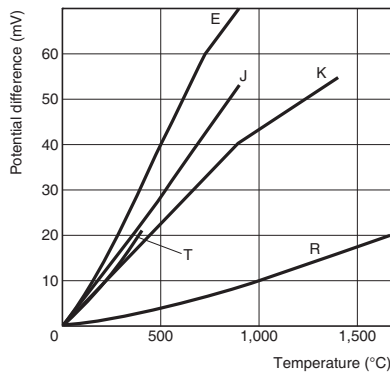

## Normal Mode Rejection Ratio

Describes how well an instrument can reject the effect of normal-mode voltage entering on the input from the output. It is usually expressed in decibels (dB). It is the ratio between the normal-mode voltage on the input terminals of the device and the increase required in the input signals to achieve the same characteristics in the output signal.

## Normal Mode Voltage

Undesirable input voltage superimposed on the measurement voltage, such as potential difference of the measuring conductors or induction voltage. Also called series mode voltage.

## Burnout (Protection)

When there is no input, the output is increased or decreased, to whichever way is safe.

For example, when temperature is controlled using a thermocouple as the sensor, if the thermocouple breaks down due to a burnout, the input is cut off. When this is detected, it may be incorrectly determined as a temperature drop, resulting in the heat controller increasing the temperature and causing overheating. By implementing a burnout protection function, this kind of overheating can be prevented.

## Byte

A group of adjacent bits treated as one unit. Often consists of 8 bits.

## Bus

A signal communications line where many devices share the same connection. Data can be transferred from any of the signal sources to any of the receivers connected to the bus.

### • GP-IB

One of the buses established by IEEE-USA. IEEE-488

### • VME Bus

One of the buses established by IEEE-USA. IEEE-1014

### • Multibus

One of the buses established by IEEE-USA. IEEE-796

## Parity Check

A parity bit is added to a data set as a binary digit to indicate whether the number of ones in a given set of bits is even or odd. It acts as an error detecting code.

## Proportional Plus Integral Plus Derivative Control (PID Control)

A control loop that uses signals proportional to the linear combination of the input, the time integral of the input, and the time derivative of the input to control the output.

## Binary Coded Decimal (BCD)

Each digit of a decimal number is represented by four binary bits.

For example, decimal number 23 would be expressed as 0010 0011.

## Hysteresis

Properties of equipment and devices where the output value depends on the immediately preceding history of the applied input.

## Apparent Power

Apparent power is the simple product of voltage and current supplied to an AC device and is expressed in VA (volt-amperes). It describes the ability of AC devices and power sources to supply current at a given voltage to transformers and motors.

## Bit

Short for "binary digit." It is either 1 or 0, and refers to a digit in a binary numeral system. It is the smallest unit of information.

## Proportional Band

The range of change in the input (%) required for the output to go from 0% to 100% during proportional action.

## Load Resistance

Refer to *Tolerated Load Resistance*.

## Dead Band

The range of input variations where the no change is detected in the output variable. This characteristic is also called the neutral zone.

## Frame

In a multiplex structure, a message is transmitted using a time-sharing method. Under this arrangement, a frame is a set of consecutive pulse signals conveying the information on the transmission line.

## Floating Input

Input terminals that are isolated from the outer casing, power source, and various output terminals (JIS definition).

## Negative Logic

There are two ways to assign high and low voltage levels and to the information bits 0 and 1. One is to make 0 correspond to low, and 1 to high, which is called positive logic. The other is in reverse, where 0 corresponds to high and 1 to low, which is called negative logic.

## Compensating Lead Wire

An insulated pair of conductors with similar properties to the thermocouple is connected between the thermocouple terminals and the reference junction to compensate for measurement errors caused by temperature change at the thermocouple terminals.

## Reactive Power

The portion of power supply (apparent power) that is actually used by an AC machine is the active power, and the portion of power due to stored energy, which returns to the source in each cycle, is known as reactive power. The unit for reactive power is Var.

It is the product of the voltage and current flowing in the device multiplied by the sine value of the phase difference ( $\theta$ ).

$$\text{Reactive power } Q = \text{Voltage } E \times \text{Current } I \times \text{Reactive ratio } \sin\theta \text{ (Var)}$$

and

$$\text{Active power } P^2 + \text{Reactive power } Q^2 = \text{Apparent power } S^2$$

## Active Power

The portion of the power supply that is used by an AC machine is called active power, in units of W (watts). It is the product of voltage, current, and the cosine value of the phase difference ( $\theta$ ). The value  $\cos\theta$  is referred as the power ratio, meaning the portion of power that is useful.

## Power Factor

When AC voltage  $E$  is applied to a load (the device), the phase of the AC current  $I$  flowing in it generally lags behind the voltage  $E$  by amount  $\theta$ . More specifically, when the load is purely resistive, there is no phase shift. When the load is inductive (i.e. a coil), it lags by  $\theta$ . When the load is capacitive (i.e. a condenser), it leads by  $\theta$ .

## Linearizer

For example with a thermocouple, a detection signal (mV) which has a non-linear relationship with the measurement (temperature) can be used as an input. A linearizer takes this signal and converts it into an output signal that is proportional (linear relationship) to the measured value.

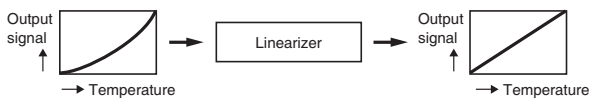

## Relay Contact

- **Make contact**  
(normally open (NO) contact)
- **Break contact**  
(normally closed (NC) contact)
- **Transfer contact**  
(double-throw contact)

Made from two contacts, one normally open contact and one normally closed contact with a common terminal.

## Cold Junction Compensation

Also called reference junction compensation. When measuring temperature using thermocouples, the reference terminal may not be held at  $0^\circ\text{C}$ , but at the surrounding temperature of  $T_1^\circ\text{C}$  instead. Without any compensation, the thermocouple output will be reduced by  $T_1^\circ\text{C}$ . This is compensated by adding potential difference to the internal amplifier corresponding to  $T_1^\circ\text{C}$ .

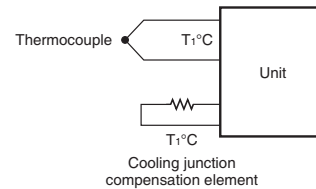

## Range

The difference between minimum and maximum values that an input or output can reach.

## Load Cell

A load cell is a sensor that detects load or force. A strain gauge is a commonly used type of load cell.

### • Bridge Resistance

The standard resistance seen from the load cell input/output terminals (A/B/CD) at ambient temperature. Normally  $350\ \Omega$ .

### • Excitation Voltage

Supply voltage applied across the load cell bridge resistance (A–B), normally 5 or 10 V.

### • Rated Output Voltage

The voltage output when the maximum load corresponding to an additional 1 V is applied to the load cell. Normally 2 mV/V.

## Further Information

### Measuring Other Forms of Signals, Sensor Signals, and Non-linear Signals

To measure anything related to electrical output, such as power, reactive power, power factor, frequency or phase, any signals from sensors, or any non-linear signals, install a power transducer or a signal converter to convert DC voltage into DC current.

Power	K3FL-W□□
Reactive power	K3FL-Q□□
Power factor	K3FL-C□□
Frequency	K3FL-F□□
Phase	K3FL-P□□
Load cell	K3FK-G/GS
Non-linear signal	K3FK-X

### Summary of Element Symbols

Element	Symbol		Details
	Denotation in product catalogs	Denotation by JIS	
NO contact			Contacts are open when the relay is inactive.
NC contact			Contacts are closed when relay is inactive.
Double-throw contact			Transfer contacts (also called double-throw contacts) control two circuits, one normally open contact and one normally closed contact with a common terminal.
Diode			
Photocoupler			
AC power source			
DC power source			
NPN transistor			
PNP transistor			
Zener diode			

### Parameter Display

The following symbols are used to represent the characters for parameter names on a Digital Panel Indicator.

A	b	C	d	E	F	G	H	I	J	K	L	M	N	O	P	Q	R	S	T	U	V	W	X	Y	Z
A	B	C	D	E	F	G	H	I	J	K	L	M	N	O	P	Q	R	S	T	U	V	W	X	Y	Z