

CJ-series DeviceNet Unit

CJ1W-DRM21

CSM_CJ1W-DRM21_DS_E_8_9

Smallest in the Industry! A DeviceNet Unit for the CJ Series that Boasts Industry-leading Performance and Functions



CJ1W-DRM21

Features

- Allows control of up to 32,000 points (2,000 words) per master, and ensures a high degree of simultaneity between data.
- Can be used as both a master and a slave at the same time.
- Equipped with settings and monitor functions aimed at improving both design and startup efficiency. Achieve maximum performance by using in combination with a Configurator.
- Files of master and slave settings can be uploaded and downloaded using memory cards, allowing effective debugging and easier setup.

System Configuration

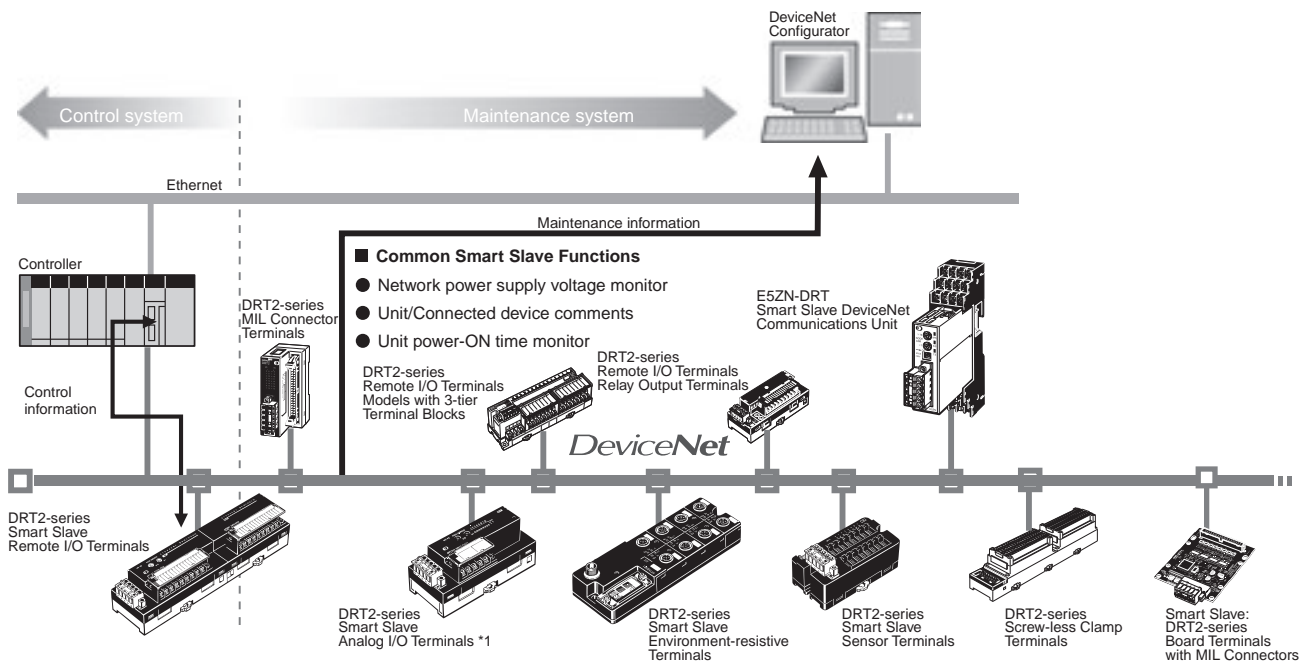

Reduce Setup Time

- Network power supply monitor function
- Input filter function
- Power-ON inrush current protection function
- Communications speed auto-detect function
- Scaling function
- User compensation function
- Cumulative counter
- Moving average processing function
- Number of A/D conversion points (conversion cycle) setting
- Peak/bottom hold function
- Top/valley hold function
- Percentage change calculation function

Reduce Downtime

- Unit comments function
- Connected device comments function
- I/O power supply monitor function
- Sensor power supply short-circuit detection function
- External load short-circuit detection function
- Disconnected sensor detection function

Improve Maintenance

- Operation time monitor function
- Contact operations counter (See note.)
- Unit conduction time monitor function
- Total ON time monitor function (See note.)
- Network power supply voltage monitor function
- Communications error log function
- Last maintenance date
- Comparator function
- Selectable output value after error

Note: The number of contact operations monitor function and the cumulative ON time monitor function cannot be used simultaneously for the same contact.

*1. Analog Output Terminal in this catalog have been discontinued.

Communication Specifications

Item	Specifications			
Communications protocol	DeviceNet			
Connection methods	Multi-drop and T-branch connections can be combined (for trunk and branch lines) *1			
Baud rate	500 Kbps, 250 Kbps, or 125 Kbps			
Communications media	Special 5-wire cables (2 signal lines, 2 power lines, 1 shield line) Special 4-wire flat cables (2 signal lines, 2 power lines)			
Communications distances for special 5-wire cables	Baud rate	Network length	Branch line length	Total branch line length
	500 kbps	100 m max.	6 m max.	39 m max.
	250 kbps	250 m max. *2	6 m max.	78 m max.
Communications distances for special 4-wire flat cables	Baud rate	Network length	Branch line length	Total branch line length
	500 kbps	75 m max.	6 m max.	35 m max.
	250 kbps	150 m max.	6 m max.	48 m max.
125 kbps	265 m max.	6 m max.	135 m max.	
Communications power supply	24 V DC supplied externally			
Max. number of nodes	64 nodes (including Masters, Slaves, and Configurator)			

*1. Terminators are required at both ends of trunk line.

*2. Indicates the maximum network length when thick cables are used. Reduce the network length to 100 m max. when using thin cables.

Network Specifications

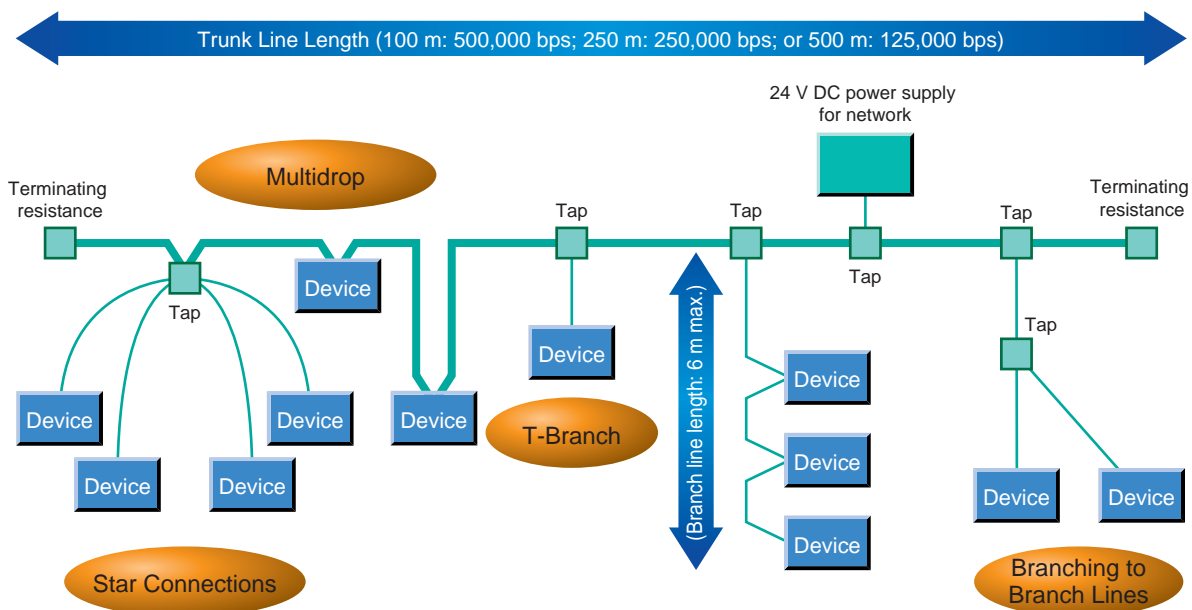

Ordering Information

International Standards

- The standards are abbreviated as follows: U: UL, U1: UL(Class I Division 2 Products for Hazardous Locations), C: CSA, UC: cULus, UC1: cULus (Class I Division 2 Products for Hazardous Locations), CU: cUL, N: NK, L: Lloyd, and CE: EC Directives.
- Contact your OMRON representative for further details and applicable conditions for these standards.

Unit classification	Product name	Specifications	Communications	No. of unit numbers allocated	Current consumption (A)		Model
					5 V	24 V	
CJ1 CPU Bus Unit		Equipped with Master and Slave functionality. Controls for up to 32,000 points per Master.	<ul style="list-style-type: none"> Remote I/O Communications Master (fixed allocations or user-set allocations) Remote I/O Communications Slave (fixed allocations or user-set allocations) Message communications 	1	0.29	–	CJ1W-DRM21

Note: When using with the Machine Automation Controller NJ Series, note the following points:

- Simple backup function cannot be used.
- DeviceNet configurator cannot be used. Use CX-Integrator.

Software

How to Select Required Support Software for Your Controller

The required Support Software depends on the Controller to connect. Please check the following table when purchasing the Support Software.

Item	Omron PLC System	Omron Machine Automation Controller System
Controller	CS, CJ, CP, and other series	NJ-series
Software	FA Integrated Tool Package CX-One	Automation Software Sysmac Studio

FA Integrated Tool Package CX-One

Product name	Specifications	Number of licenses	Media	Model	Standards

*1. Multi licenses (3, 10, 30, or 50 licenses) and DVD media without licenses are also available for the CX-One.

*2. The CX-One is also available on CD (CXONE-AL□□C-V4).

Automation Software Sysmac Studio

Please purchase a DVD and required number of licenses the first time you purchase the Sysmac Studio. DVDs and licenses are available individually. Each model of licenses does not include any DVD.

Product name	Specifications	Number of licenses	Media	Model	Standards
		– (Media only)	Sysmac Studio (64-bit) DVD	SYSMAC-SE200D-64	–
		1 license *2	–	SYSMAC-SE201L	–

*1. Model "SYSMAC-SE200D-64" runs on Windows 10 (64 bit) or higher.

*2. Multi licenses are available for the Sysmac Studio (3, 10, 30, or 50 licenses).

Specifications

Communications power supply voltage		11 to 25 VDC *1		
Current consumption		Communications: 18 mA max. Internal circuit: 290 mA max.		
Max. number of connectable slaves	Remote I/O, explicit message service		63 *2	
Max. number of I/O points	Fixed allocations		When used as a master	2,048 points
			When used as a slave	32 points
	User-set allocations	Using allocated DM Area words	When used as a master	16,000 points
			When used as a slave	3,200 points
		Using Configurator	When used as a master	32,000 points
			When used as a slave	4,800 points
Number of allocated words	Fixed allocations		When used as a master	64 input and 64 output words Software switch/status area: 25 words
			When used as a slave	1 input word, 1 output word *3
	User-set allocations	Using allocated DM Area words	When used as a master	500 input and 500 output words Software switch/status area: 25 words
			When used as a slave	100 input and 100 output words *3 Software switch/status area: 25 words
		Using Configurator	When used as a master	500 input words x 2 blocks, 500 output words x 2 blocks Software switch/Status area: 25 words
			When used as a slave	100 input words x 1 blocks, 100 output words x 2 blocks (See note 3.) Software switch/Status area: 25 words
Message communications	Max. message length		542 bytes *4	
Applicable Controllers			CJ/NJ Series	
Max. number of Units mountable to Controller	Fixed allocations		3	
	User-set allocations		16	
Weight			118 g max.	

*1. Refer to the DeviceNet Operation Manual (W267) for the communications power supply specifications.

*2. The Device Unit uses a node, and so connection is possible to 63 slaves only.

*3. When the DeviceNet is used as a slave, "input" and "output" respectively refer to input from the slave to the master and output from the master to the slave.

*4. The maximum message length includes the command code when using the CMND instruction. (SendCmd instruction with NJ-series controller)

External Interface

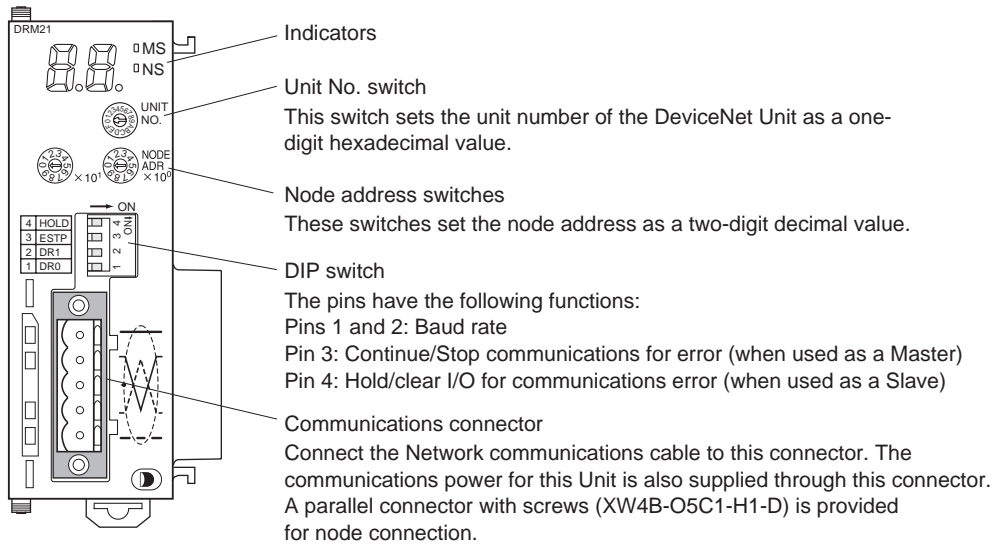

Communications Connectors

Color stickers that match communications cable colors are attached to the communications connectors. Match the colors when connecting communications cables to the connectors. These colors are given in the following table

Color	Signal
Black	Power line, negative voltage (V-)
Blue	Communications line, low (CAN L)
-	Shield
White	Communications line, high (CAN H)
Red	Power line, positive voltage (V+)

Dimensions

(Unit: mm)

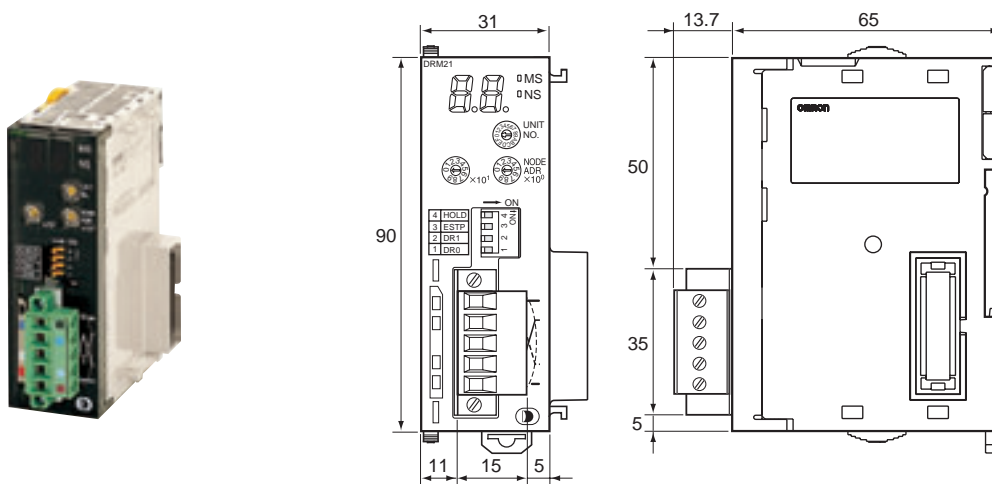

Related Manuals

Manual name	Cat. No.	Model numbers	Application	Description
CS/CJ Series DeviceNet Unit Operation Manual	W380	CS1W-DRM21(-V1) CJ1W-DRM21	Learning about the functions and operating procedure for CS/CJ Series DeviceNet Units.	The functions and operating procedures when the CS/CJ Series DeviceNet Unit is used in CS/CJ series system configuration are described.
CJ-series DeviceNet Units Operation Manual for NJ-series CPU Unit	W497	CJ1W-DRM21	Learning about the functions and operating procedures when the CJ-series DeviceNet Unit is used in an NJ-series system configuration.	The functions and operating procedures when the CJ-series DeviceNet Unit is used in an NJ-series system configuration are described.
DeviceNet Configurator Ver. 2. <input type="checkbox"/> Operation Manual	W382	–	Learning about the operating procedures for DeviceNet Configurator.	The operating procedures for DeviceNet Configurator are described in details.
DeviceNet Operation Manual	W267	–	Learning about the communications specifications and wiring methods common among the DeviceNet communications networks.	The communications specifications and wiring methods common among the DeviceNet communications networks are described. Please read this manual and familiarize yourself with the functions and characteristics of the DeviceNet before use.
DRT2 Series DeviceNet Slaves Operation Manual	W404	DRT2-ID/OD/ MD32SL(H)(-1) DRT2-MD16S DRT2 Series	Learning about the DRT2 Series DeviceNet Slaves.	The types of DRT2 DeviceNet Slaves, the functions, specifications, and operating procedures are described in details.
GT1 Series DeviceNet Multiple I/O Terminal Operation Manual	W348	DRT1-COM GT1 Series	Learning about the Multiple I/O Terminal, which is a type of DeviceNet Slave.	The types of Multiple I/O Terminal, which are kinds of DeviceNet Slaves, are provided. Also, their functions, specifications, and operating procedures are described in details.
CX-Integrator Ver.2. <input type="checkbox"/> Operation Manual	W464	–	Learning about the CX-Integrator that is used to set up the DeviceNet networks and to make settings.	The operating procedures for CX-Integrator are described.

Terms and Conditions Agreement

Read and understand this catalog.

Please read and understand this catalog before purchasing the products. Please consult your OMRON representative if you have any questions or comments.

Warranties.

(a) Exclusive Warranty. Omron's exclusive warranty is that the Products will be free from defects in materials and workmanship for a period of twelve months from the date of sale by Omron (or such other period expressed in writing by Omron). Omron disclaims all other warranties, express or implied.

(b) Limitations. OMRON MAKES NO WARRANTY OR REPRESENTATION, EXPRESS OR IMPLIED, ABOUT NON-INFRINGEMENT, MERCHANTABILITY OR FITNESS FOR A PARTICULAR PURPOSE OF THE PRODUCTS. BUYER ACKNOWLEDGES THAT IT ALONE HAS DETERMINED THAT THE PRODUCTS WILL SUITABLY MEET THE REQUIREMENTS OF THEIR INTENDED USE.

Omron further disclaims all warranties and responsibility of any type for claims or expenses based on infringement by the Products or otherwise of any intellectual property right. (c) Buyer Remedy. Omron's sole obligation hereunder shall be, at Omron's election, to (i) replace (in the form originally shipped with Buyer responsible for labor charges for removal or replacement thereof) the non-complying Product, (ii) repair the non-complying Product, or (iii) repay or credit Buyer an amount equal to the purchase price of the non-complying Product; provided that in no event shall Omron be responsible for warranty, repair, indemnity or any other claims or expenses regarding the Products unless Omron's analysis confirms that the Products were properly handled, stored, installed and maintained and not subject to contamination, abuse, misuse or inappropriate modification. Return of any Products by Buyer must be approved in writing by Omron before shipment. Omron Companies shall not be liable for the suitability or unsuitability or the results from the use of Products in combination with any electrical or electronic components, circuits, system assemblies or any other materials or substances or environments. Any advice, recommendations or information given orally or in writing, are not to be construed as an amendment or addition to the above warranty.

See <http://www.omron.com/global/> or contact your Omron representative for published information.

Limitation on Liability: Etc.

OMRON COMPANIES SHALL NOT BE LIABLE FOR SPECIAL, INDIRECT, INCIDENTAL, OR CONSEQUENTIAL DAMAGES, LOSS OF PROFITS OR PRODUCTION OR COMMERCIAL LOSS IN ANY WAY CONNECTED WITH THE PRODUCTS, WHETHER SUCH CLAIM IS BASED IN CONTRACT, WARRANTY, NEGLIGENCE OR STRICT LIABILITY.

Further, in no event shall liability of Omron Companies exceed the individual price of the Product on which liability is asserted.

Suitability of Use.

Omron Companies shall not be responsible for conformity with any standards, codes or regulations which apply to the combination of the Product in the Buyer's application or use of the Product. At Buyer's request, Omron will provide applicable third party certification documents identifying ratings and limitations of use which apply to the Product. This information by itself is not sufficient for a complete determination of the suitability of the Product in combination with the end product, machine, system, or other application or use. Buyer shall be solely responsible for determining appropriateness of the particular Product with respect to Buyer's application, product or system. Buyer shall take application responsibility in all cases.

NEVER USE THE PRODUCT FOR AN APPLICATION INVOLVING SERIOUS RISK TO LIFE OR PROPERTY OR IN LARGE QUANTITIES WITHOUT ENSURING THAT THE SYSTEM AS A WHOLE HAS BEEN DESIGNED TO ADDRESS THE RISKS, AND THAT THE OMRON PRODUCT(S) IS PROPERLY RATED AND INSTALLED FOR THE INTENDED USE WITHIN THE OVERALL EQUIPMENT OR SYSTEM.

Programmable Products.

Omron Companies shall not be responsible for the user's programming of a programmable Product, or any consequence thereof.

Performance Data.

Data presented in Omron Company websites, catalogs and other materials is provided as a guide for the user in determining suitability and does not constitute a warranty. It may represent the result of Omron's test conditions, and the user must correlate it to actual application requirements. Actual performance is subject to the Omron's Warranty and Limitations of Liability.

Change in Specifications.

Product specifications and accessories may be changed at any time based on improvements and other reasons. It is our practice to change part numbers when published ratings or features are changed, or when significant construction changes are made. However, some specifications of the Product may be changed without any notice. When in doubt, special part numbers may be assigned to fix or establish key specifications for your application. Please consult with your Omron's representative at any time to confirm actual specifications of purchased Product.

Errors and Omissions.

Information presented by Omron Companies has been checked and is believed to be accurate; however, no responsibility is assumed for clerical, typographical or proofreading errors or omissions.