

D4SL-N / D4SL-NSK10-LK

Varied lineup of Guard Lock Safety-door Switches



<Guard Lock Safety-door Switch D4SL-N>

- Wiring time is reduced with two types of wiring methods capable of one-touch attachment and removal.
- A wide variety of built-in switches can be used for various devices.
(4-, 5-, and 6-contact models are available)
- Key holding force of 1,300 N.
- It is possible to change the operation key insertion point without detaching the head.
- Drive solenoids directly from the Controller.

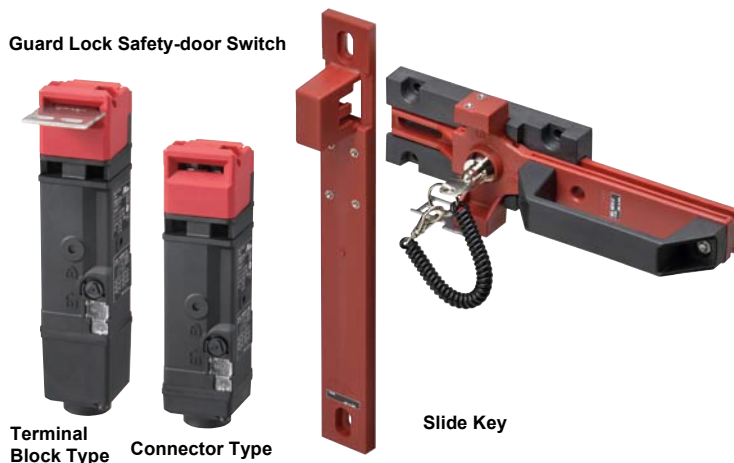

<Slide Key D4SL-NSK10-LK

- Lockout key to prevent workers from becoming trapped inside the hazardous area.
- The vertical D4SL-N Guard Lock Safety-door Switch can be easily mounted on 40 × 40 mm aluminum frames.
- The plastic material makes the Slide Key suitable for lightweight doors.

For the most recent information on models that have been certified for safety standards, refer to your OMRON website.



Be sure to read the "Safety Precautions" on page 22.

Scan the 2D codes using the smartphone to see the D4SL-N promotional videos.

Reduction in time and effort



Safe access application



Model Number Structure

Model Number Legend

Switch

D4SL-N (1) (2) (3) (4) - (5) (6) (7)

(1) Conduit Outlet

Code	Conduit Outlet
2	G1/2
3	1/2-14NPT *1
4	M20

*1. The recommended models for equipment and machinery being exported to Europe are those with an M20 conduit outlet, and for North America, the recommended models are those with a 1/2-14NPT conduit outlet.
1/2-14NPT models (conduit outlet: M20) will come with an M20-to-1/2-14NPT conversion adapter.

(2) Built-in Switch (Total number of contacts/Door monitor/Lock monitor)

Code (Circuit number *2)	Total number of contacts	Door monitor	Lock monitor	Presence/absence of short circuit in door monitor/lock monitor
A	4-contact	2-contact (1NC/1NO)	2-contact (1NC/1NO)	Yes
B		2-contact (1NC/1NO)	2-contact (2NC)	
C		2-contact (2NC)	2-contact (1NC/1NO)	
D		2-contact (2NC)	2-contact (2NC)	
S	4-contact	2-contact (1NC/1NO)	2-contact (1NC/1NO)	None
T		2-contact (1NC/1NO)	2-contact (2NC)	
U		2-contact (2NC)	2-contact (1NC/1NO)	
V		2-contact (2NC)	2-contact (2NC)	
E	5-contact	3-contact (2NC/1NC)	2-contact (1NC/1NO)	Yes
F		3-contact (2NC/1NC)	2-contact (2NC)	
G		3-contact (3NC)	2-contact (1NC/1NO)	
H		3-contact (3NC)	2-contact (2NC)	
N	6-contact	3-contact (2NC/1NC)	3-contact (2NC/1NC)	None
P		3-contact (2NC/1NC)	3-contact (3NC)	
Q		3-contact (3NC)	3-contact (2NC/1NC)	
R		3-contact (3NC)	3-contact (3NC)	

*2. For detailed internal circuit information, please refer to *Model and Contact Configuration* on page 13.

(3) Head Material

Code	Head Material
F	Resin
D *3	Metal

*3. 4-contact type is not available.

(4) Door Lock and Release

Code	Door Lock	Release
A	Mechanical lock	Solenoid release (24 VDC)
G	Solenoid lock (24 VDC)	Mechanical release

(5) Indicator

Code	Indicator
- (Blank) *4	None
D *4	24 VDC (orange LED indicator)

*4. Code - (Blank): 5- and 6-contact types are not available.
Code D: 4-contact type is not available.

(6) Release Key Type

Code	Release Key Type
- (Blank)	Standard release key (metal)
4 *5	Special release key (resin) (Note: Release keys are provided.)

*5. 4-contact type is not available.

(7) Connection Method

Code	Connection Method
- (Blank)	Terminal block
N	Connector *6

*6. Connector cables are not included with the connector type and are to be purchased separately.

Operation Key**D4SL-NK** (1) (2)**(1) Operation Key Type**

Code	Operation Key Type
1	Horizontal mounting
2	Vertical mounting
3	Adjustable mounting (horizontal)
5	Adjustable mounting (horizontal/vertical)

(2) Key Type

Code	Key Type
– (Blank)	No cushion rubber
G	Cushion rubber
S	No cushion rubber, short type

Slide Key**D4SL-NSK10-LK** (1) - (2)**(1) Inner Lever**

Code	Inner Lever
– (Blank)	No inner lever
H	With inner lever

(2) Lockout key Type

Code	Lockout key Type
– (Blank)	01
02 to 30	02 to 30

Note: Lockout key can be created up to 30 types.







Ordering Information

List of Models

Total number of contacts	Lock monitor	Door monitor	Circuit (Door monitor and Lock monitor)	Door Lock	Head Material	Indicator	Connection Method	Release Key type	Conduit Outlet	Model
6-contact	3-contact (2NC/1NO)	3-contact (2NC/1NO)	<p>Circuit number: N</p>	Mechanical lock	Resin	Yes	Terminal block	Standard	G1/2	D4SL-N2NFA-D
					Resin	Yes	Terminal block	Standard	M20	D4SL-N4NFA-D
					Resin	Yes	Connector	Standard	G1/2	D4SL-N2NFA-DN
					Resin	Yes	Terminal block	Special (resin)	G1/2	D4SL-N2NFA-D4
				Solenoid lock	Resin	Yes	Terminal block	Standard	G1/2	D4SL-N2NFG-D
					Resin	Yes	Terminal block	Standard	M20	D4SL-N4NFG-D
6-contact	3-contact (3NC)	3-contact (3NC)	<p>Circuit number: R</p>	Mechanical lock	Resin	Yes	Terminal block	Standard	G1/2	D4SL-N2RFA-D
				Solenoid lock	Resin	Yes	Terminal block	Standard	G1/2	D4SL-N2RFG-D
				5-contact	2-contact (2NC)	3-contact (3NC)	<p>Circuit number: H</p>	Mechanical lock	Resin	Yes
Solenoid lock	Resin	Yes	Terminal block	Standard				G1/2	D4SL-N2HFG-D	
5-contact	2-contact (2NC)	3-contact (2NC+1NO)	<p>Circuit number: F</p>	Mechanical lock	Resin	Yes	Terminal block	Standard	G1/2	D4SL-N2FFA-D
				Solenoid lock	Resin	Yes	Terminal block	Standard	G1/2	D4SL-N2FFG-D

Note: 1. For other models, refer to the *Model Number Structure*.
 2. For detailed internal circuit information, please refer to *Model and Contact Configuration* on page 13.

Operation Keys



Type	Model
Horizontal mounting 	D4SL-NK1
Horizontal mounting (Short) 	D4SL-NK1S
Horizontal mounting (Cushion rubber) 	D4SL-NK1G
Vertical mounting 	D4SL-NK2
Vertical mounting (Cushion rubber) 	D4SL-NK2G
Adjustable (Horizontal) 	D4SL-NK3
Adjustable (Horizontal/Vertical) 	D4SL-NK5

Connector Cables

Cable length	Model
1 m	D4SL-CN1
3 m	D4SL-CN3
5 m	D4SL-CN5
10 m	D4SL-CN10

D4SL-N / D4SL-NSK10-LK□

Slide Key

Type	Specifications	Contents	Model
	Weight: Approx. 0.6 kg Mechanical durability: 20,000 operations min.	Slide Key: 1 (not yet mounted) Inner Lever: None D4SL-N mounting plate: 1 Door Switch special mounting screws: 3 D4SL-NK1 (operation key): 1 D4SL-NK1 special mounting screws: 2 Lockout keys: 2 Lockout key strap: 1 Caution labels (stickers): 2 sheets (English and Japanese)	D4SL-NSK10-LK *1
			D4SL-NSK10-LK-□ *2
	Weight: Approx. 0.1 kg	Inner Lever: 1	D4SL-SK10H *3
	Weight: Approx. 0.7 kg Mechanical durability: 20,000 operations min.	Slide Key: 1 (not yet mounted) Inner Lever: 1 D4SL-N mounting plate: 1 Door Switch special mounting screws: 3 D4SL-NK1 (operation key): 1 D4SL-NK1 special mounting screws: 2 Lockout keys: 2 Lockout key strap: 1 Caution labels (stickers): 2 sheets (English and Japanese)	D4SL-NSK10-LKH *1
			D4SL-NSK10-LKH-□ *2

Note: 1. The Door Switch is not included. Select the Door Switch depending on the necessary number of contacts and the conduit outlet.
 The contents are provided as a total set, individual contents cannot be ordered separately.
 2. Perform risk assessment for the equipment in question, configure relay units and other safety circuits, and use properly.

*1. The number for the lockout key is 01.

*2. Replace the box with 02 to 30 (lockout key number). Ask your OMRON representative for delivery times.

*3. The inner lever for D4SL-NSK10 that can not be used for other products and applications.

Applicable Door Switches

D4SL-NSK10-LK



D4SL-NSK10-LKH



Features

The lockout key prevents workers from becoming trapped without using a padlock.

Note: Using LEDs of D4SL-N enables confirming whether the door is open or closed and locked or unlocked.

Close door

Locked (power not supplied to solenoid) The slide handle is closed.

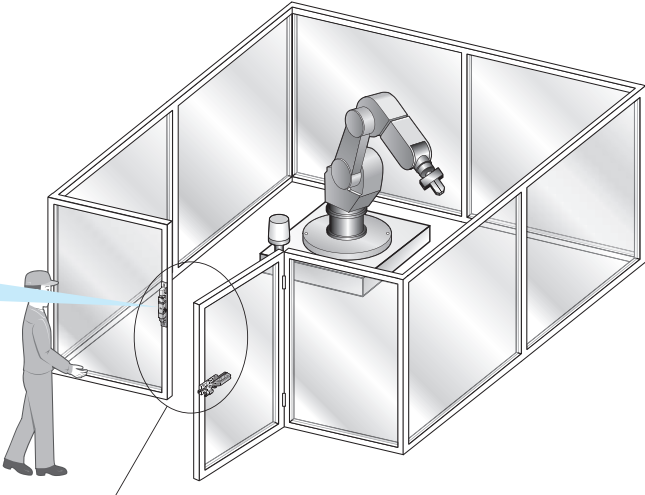
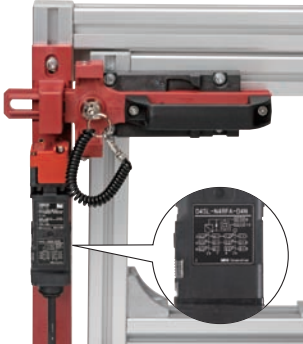

The handle-shaped fixture makes it easy to use the Door Switch.

Close door

Unlocked (power supplied to solenoid) The slide handle is closed.

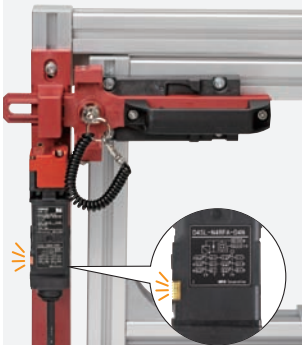

The slide handle can be pulled.

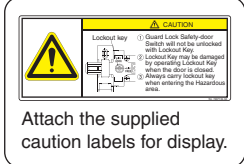

Attach the supplied caution labels for display.

Lockout Key



Do not turn the key as in the figure above if the slide handle is closed.

Left door

Door Opening to the Left.

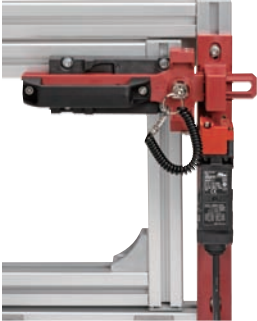

Open door

The slide handle is open.



When the slide handle is open, the lockout key can be pulled regardless of whether power is being supplied to the solenoid or not.

Open door

The slide handle is open.

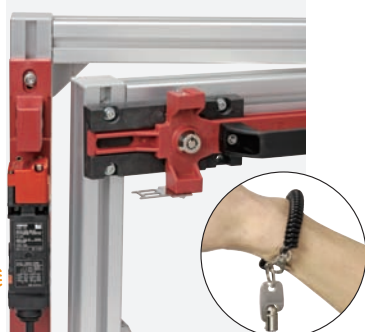

The slide handle is secured at the position shown in the figure. A worker holding the lockout key will not be trapped locked inside the hazardous area by another person.

Open door

The slide handle is open.



If the lockout key is not mounted, the slide handle will not move and the door will not close.

D4SL-N / D4SL-NSK10-LK

Structure and Nomenclature

Structure

D4SL-N□□□□-D□N Connector Type

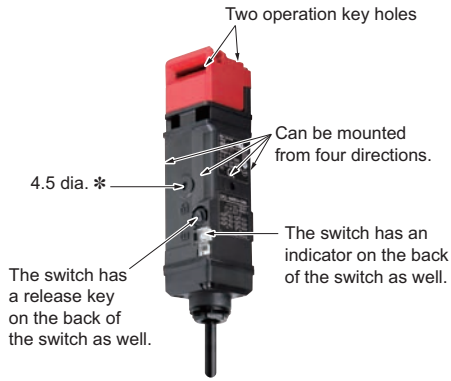

D4SL-□□□□-D□ Terminal Block Type

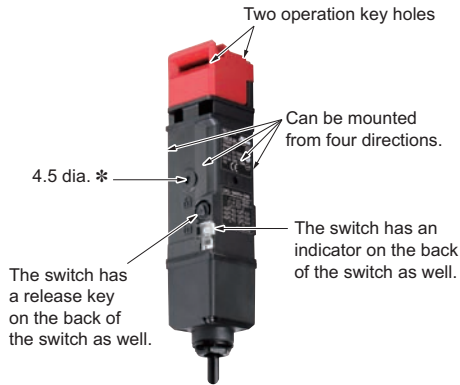

* You can insert and secure a stud or other projection in the 4.5-dia. hole to make the installation even stronger. For details, refer to "Switch and Operation Key Mounting" on page 24.

Connector/Terminal

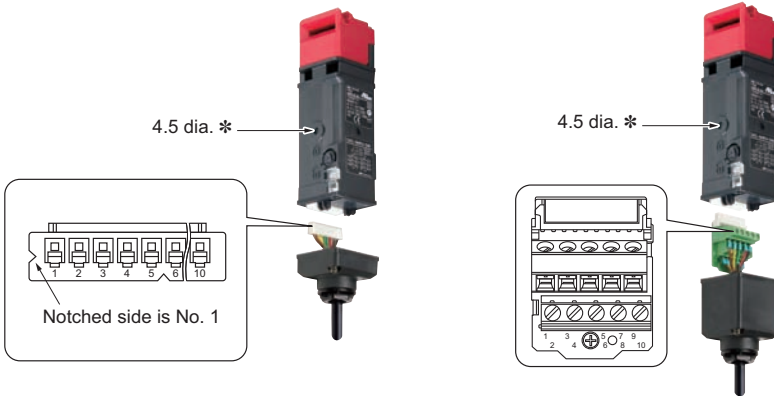

Terminal Arrangement

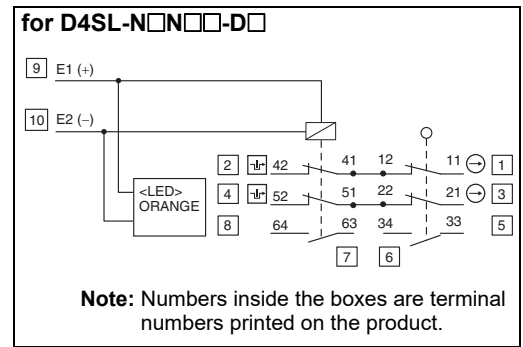

Operating Cycle Examples for Standard Models

D4SL-N□□□A-□ (Mechanical Lock Models)

Door condition		Condition 1	Condition 2	Condition 3	Turning the special release key
		Door open. The door will lock when the door closes.	Door closed. The door is locked.	Door closed. The door can be opened.	Door closed. No power is supplied to the solenoid. The door is unlocked manually.
Terminal No. and Contact No.	Function				
9 E1-10 E2	Solenoid ON				
2 42-1 11 (NC) 4 52-3 21 (NC)	Door monitor and lock monitor contacts				
3 21-4 22 (NC) 5 31-6 32 (NC)	Door monitor contact				
5 33-6 34 (NO)	Door monitor contact				
1 41-2 42 (NC) 7 61-8 62 (NC)	Lock monitor contact				
7 63-8 64 (NO)	Lock monitor contact				

D4SL-N□□□G-□ (Solenoid Lock Models)

Door condition		Even when the door is closed, it does not lock until power is supplied to the solenoid.	Door closed. The door is locked.	Door closed. The door can be opened.
Terminal No. and Contact No.	Function			
9 E1-10 E2	Solenoid ON			
2 42-1 11 (NC) 4 52-3 21 (NC)	Door monitor and lock monitor contacts			
3 21-4 22 (NC) 5 31-6 32 (NC)	Door monitor contact			
5 33-6 34 (NO)	Door monitor contact			
1 41-2 42 (NC) 7 61-8 62 (NC)	Lock monitor contact			
7 63-8 64 (NO)	Lock monitor contact			

The shaded areas indicate the contact is closed and power is supplied to the solenoid.

Door monitor and lock monitor contacts: Can be used in safety circuits because of the direct opening mechanisms.

Door monitor contact: Can be used to confirm whether the key is inserted and to monitor the open/closed status of a door.

Lock monitor contact: Can be used to confirm whether power is supplied to the solenoid and to monitor whether or not a door can be opened or closed.

Note: 1. The door monitor and lock monitor contact configuration depends on the model.

2. For solenoid lock models, be sure to supply power to the solenoid after the door is closed (after the operation key is inserted).
If the door is closed after power is supplied to the solenoid, locking the operation key may not be possible.

For details, refer to "Solenoid Lock Models" on page 23.

Specifications

Standards and EC Directives

Conforms to the following EC Directives:

- Machinery Directive
- Low Voltage Directive
- EMC Directive
- EN ISO 14119
- EN60947-5-1
- GS-ET-19

Certified Standards

Certification body	Standard	File No.
TÜV SÜD	EN60947-5-1(certified direct opening)	Consult your OMRON representative for details.
UL *1	UL508, CSA C22.2 No.14	E76675
CQC (CCC)	GB/T 14048.5	Consult your OMRON representative for details.
KOSHA *2	EN60947-5-1	Consult your OMRON representative for details.

*1. Certification has been obtained for UL CSA C22.2 No. 14.

*2. Only certain models have been certified.

Certified Standard Ratings

TÜV (EN60947-5-1) CCC (GB/T 14048.5)

Utilization category	AC-15	DC-13
Rated operating current (Ie)	1.5 A *1 1 A *2	0.22 A
Rated operating voltage (Ue)	120 V	125 V

Note: Use a 4 A fuse that conforms to IEC60127 as a short-circuit protection device. This fuse is not included with the switch.

*1. 11-42, 21-52, 21-22

*2. Other terminals

UL/CSA (UL508, CSA C22.2 No.14)

C150

Rated voltage	Carry current	Current (A)		Volt-amperes (VA)	
		Make	Break	Make	Break
120 VAC	2.5 A	15	1.5	1,800	180

R150

Rated voltage	Carry current	Current (A)		Volt-amperes (VA)	
		Make	Break	Make	Break
125 VDC	1.0 A	0.22	0.22	28	28

Solenoid Coil Characteristics

Item	24 VDC
Rated operating voltage (100% ED)	24 VDC ^{+10%} _{-15%}
Current consumption *	Power ON: 6-contact type Approx. 6.4 W at 0.26 A 4-contact/5-contact type Approx. 4.8 W at 0.2 A Constant: Approx. 2.6 W (average) at 0.2 A (max.)
Insulation	Class E (to 120°C)

* A starting current is applied to the solenoid for Approx. 10 seconds.

After this, the internal circuit switches to a constant current.

Note: For solenoid lock models, be sure to supply power to the solenoid after the door is closed (after the operation key is inserted).

If the door is closed after power is supplied to the solenoid, locking the operation key may not be possible.

For details, refer to "Solenoid Lock Models" on page 23.

Indicator

Item	LED type
Rated voltage	24 VDC
Current consumption	Approx.10 mA
Color (LED)	Orange

Characteristics

Interlock type		Type 2 (EN ISO 14119)
Coding level		Low level coded (EN ISO 14119)
Degree of protection		IP67 *1 TYPE 4X Indoor use only (UL, CSA)
Durability *2	Mechanical	1,000,000 operations min.
	Electrical	150,000 operations min. (1 A resistance at 125 VAC) *3
Operating speed		0.05 to 1 m/s
Operating frequency		4- and 5-contact Model: 30 operations minute max. 6-contact Model: 5 operations minute max.
Direct opening force *4		60 N min. (EN60947-5-1)
Direct opening travel *4		15 mm min. (EN60947-5-1)
Holding force (Fzh) *5		1,300 N min.
Contact resistance		200 mΩ max.
Minimum applicable load *6		1 mA resistive load at 5 VDC (N-level reference value)
Rated insulation voltage (Ui)		150 V (EN60947-5-1)
Rated frequency		50/60 Hz
Protection against electric shock		Class II (double insulation) □
Pollution degree (operating environment)		3 (EN60947-5-1)
Impulse withstand voltage (Uimp) (EN60947-5-1)	Between terminals of same polarity	1.5 kV
	Between terminals of different polarity	1.5 kV
	Between other terminals and non-current carrying metallic parts	2.5 kV
Insulation resistance		100 Ω min. (at 500 VDC)
Vibration resistance	Malfunction	10 to 55 Hz, 0.35 mm single amplitude
Shock resistance	Malfunction	80 m/s ² min.
	Destruction	1,000 m/s ² min.
Conditional short-circuit current		100 A (EN60947-5-1)
Conventional free air thermal current (Ith)		2.5A (11-42, 21-52, 21-22) 1A (Others)
Ambient operating temperature		-10 to 55°C (with no icing)
Ambient operations humidity		95% max.
Weight		Head: Resin Approx. 290 g (Connector model) Approx. 330 g (Terminal block model) Head: Metal Approx. 370 g (Connector model) Approx. 410 g (Terminal block model)

Note: 1. The above values are initial values.

2. The Switch contacts can be used with either standard loads or microloads.

Once the contacts have been used to switch a load, however, they cannot be used to switch smaller loads.

The contact surfaces will become rough once they have been used and contact reliability for smaller loads may be reduced.

*1. The degree of protection is tested using the method specified by the standard (EN60947-5-1).

Confirm that sealing properties are sufficient for the operating conditions and environment beforehand.

Although the switch box is protected from dust, oil or water penetration, do not use the D4SL in places where cutting chips, oil, water or chemicals may enter through the key hole on the head, otherwise Switch damage or malfunctioning may occur.

*2. The durability is for an ambient temperature of 5 to 35°C and an ambient humidity of 40% to 70%. For more details, consult your OMRON representative.

*3. Do not pass the 1 A, 125 VAC load through more than 3 circuits.

*4. These figures are minimum requirements for safe operation.

*5. This figure is based on the ISO 14119 evaluation method.

*6. This value will vary with the switching frequency, environment, and reliability level.

Confirm that correct operation is possible with the actual load beforehand.

Connection

Internal Circuit Diagram

Without indicator

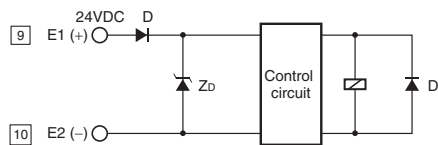

With indicator

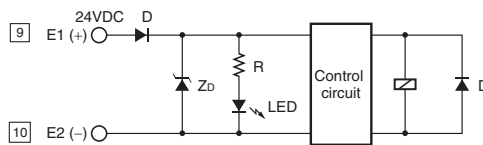

Note: The numbers in boxes are the terminal numbers given on the Switch.

Model and Contact Configuration

Indicates conditions where the Key is inserted and the lock is applied.

Circuit number Model	Total number of contacts (Door monitor and Lock monitor)	Contact Form		Operating pattern	Remarks
		Lock monitor	Door monitor		
Circuit number: A D4SL-N□A□□-□	4-contact (1NC/1NO+ 1NC/1NO)				Only NC contacts 11-12 have a certified direct opening mechanism. ⊖ The terminals 42-11, 34-33, and 64-63 can be used as unlike poles.
Circuit number: B D4SL-N□B□□-□	4-contact (1NC/1NO+2NC)				Only NC contacts 11-12 have a certified direct opening mechanism. ⊖ The terminals 42-11, 34-33, and 62-61 can be used as unlike poles.
Circuit number: C D4SL-N□C□□-□	4-contact (2NC+1NC/1NO)				Only NC contacts 11-12 and 31-32 have a certified direct opening mechanism. ⊖ The terminals 42-11, 32-31, and 64-63 can be used as unlike poles.
Circuit number: D D4SL-N□D□□-□	4-contact (2NC+2NC)				Only NC contacts 11-12 and 31-32 have a certified direct opening mechanism. ⊖ The terminals 42-11, 32-31, and 62-61 can be used as unlike poles.
Circuit number: S D4SL-N□S□□-□	4-contact (1NC/1NO+ 1NC/1NO)				Only NC contacts 21-22 have a certified direct opening mechanism. ⊖ The terminals 42-41, 22-21, 34-33, and 64-63 can be used as unlike poles.
Circuit number: T D4SL-N□T□□-□	4-contact (1NC/1NO+2NC)				Only NC contacts 21-22 have a certified direct opening mechanism. ⊖ The terminals 42-41, 22-21, 34-33, and 62-61 can be used as unlike poles.
Circuit number: U D4SL-N□U□□-□	4-contact (2NC+1NC/1NO)				Only NC contacts 21-22 and 31-32 have a certified direct opening mechanism. ⊖ The terminals 42-41, 22-21, 32-31, and 64-63 can be used as unlike poles.
Circuit number: V D4SL-N□V□□-□	4-contact (2NC+2NC)				Only NC contacts 21-22 and 31-32 have a certified direct opening mechanism. ⊖ The terminals 42-41, 22-21, 32-31, and 62-61 can be used as unlike poles.

Circuit number Model	Total number of contacts (Door monitor and Lock monitor)	Contact Form		Operating pattern	Remarks
		Lock monitor	Door monitor		
Circuit number: E D4SL-N□E□□-□	5-contact (2NC/1NO+1NC/1NO)				Only NC contacts 11-12 and 21-22 have a certified direct opening mechanism. ⊖ The terminals 42-11, 22-21, 34-33, and 64-63 can be used as unlike poles.
Circuit number: F D4SL-N□F□□-□	5-contact (2NC/1NO+2NC)				Only NC contacts 11-12 and 21-22 have a certified direct opening mechanism. ⊖ The terminals 42-11, 22-21, 34-33, and 62-61 can be used as unlike poles.
Circuit number: G D4SL-N□G□□-□	5-contact (3NC+1NC/1NO)				Only NC contacts 11-12 ,21-22 and 31-32 have a certified direct opening mechanism. ⊖ The terminals 42-11, 22-21, 32-31, and 64-63 can be used as unlike poles.
Circuit number: H D4SL-N□H□□-□	5-contact (3NC+2NC)				Only NC contacts 11-12 ,21-22 and 31-32 have a certified direct opening mechanism. ⊖ The terminals 42-11, 22-21, 32-31, and 62-61 can be used as unlike poles.
Circuit number: N D4SL-N□N□□-□	6-contact (2NC/1NO+2NC/1NO)				Only NC contacts 11-12 and 21-22 have a certified direct opening mechanism. ⊖ The terminals 42-11, 52-21, 34-33, and 64-63 can be used as unlike poles.
Circuit number: P D4SL-N□P□□-□	6-contact (2NC/1NO+3NC)				Only NC contacts 11-12 and 21-22 have a certified direct opening mechanism. ⊖ The terminals 42-11, 52-21, 34-33, and 62-61 can be used as unlike poles.
Circuit number: Q D4SL-N□Q□□-□	6-contact (3NC+2NC/1NO)				Only NC contacts 11-12 ,21-22 and 31-32 have a certified direct opening mechanism. ⊖ The terminals 42-11, 52-21, 32-31, and 64-63 can be used as unlike poles.
Circuit number: R D4SL-N□R□□-□	6-contact (3NC+3NC)				Only NC contacts 11-12 ,21-22 and 31-32 have a certified direct opening mechanism. ⊖ The terminals 42-11, 52-21, 32-31, and 62-61 can be used as unlike poles.

Dimensions and Operating Characteristics

(Unit:mm)

Switches

D4SL-N□□□□-□N (Connector Type)

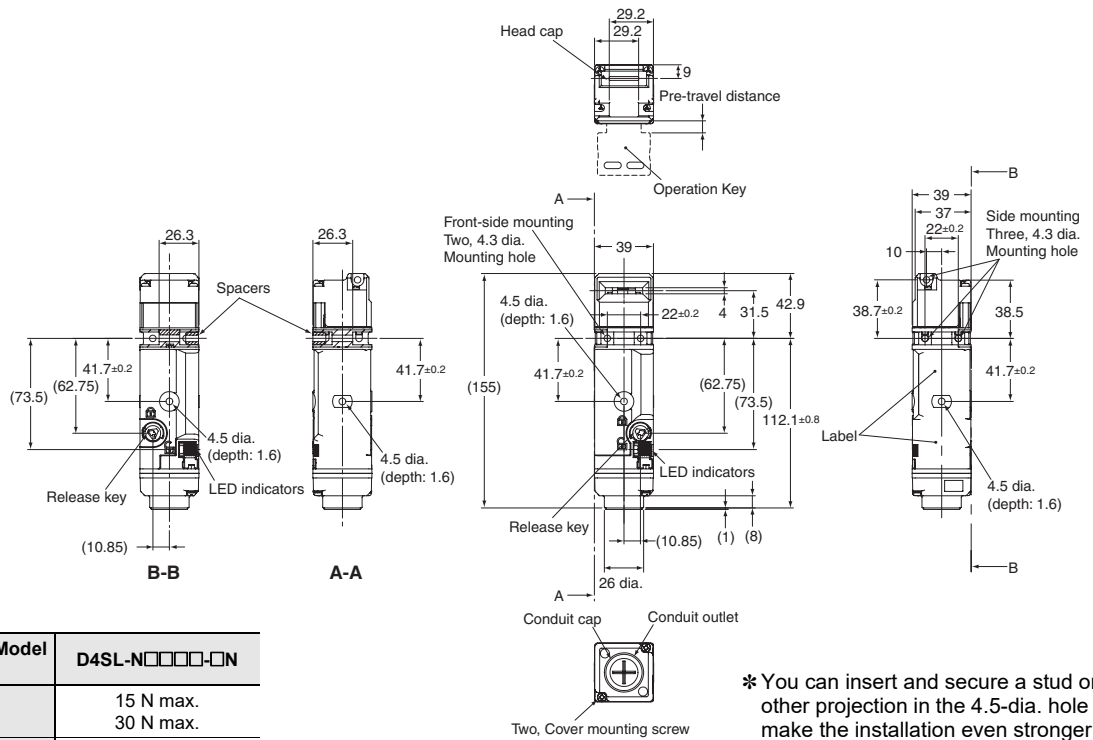

Model	D4SL-N□□□□-□N
Operating characteristics	
Key insertion force	15 N max.
Key extraction force	30 N max.
Pre-travel distance	15 mm max.
Movement before being locked	3 mm min.

* You can insert and secure a stud or other projection in the 4.5-dia. hole to make the installation even stronger. For details, refer to "Switch and Operation Key Mounting" on page 24.

D4SL-N□□□□-□ (Terminal Block Type)

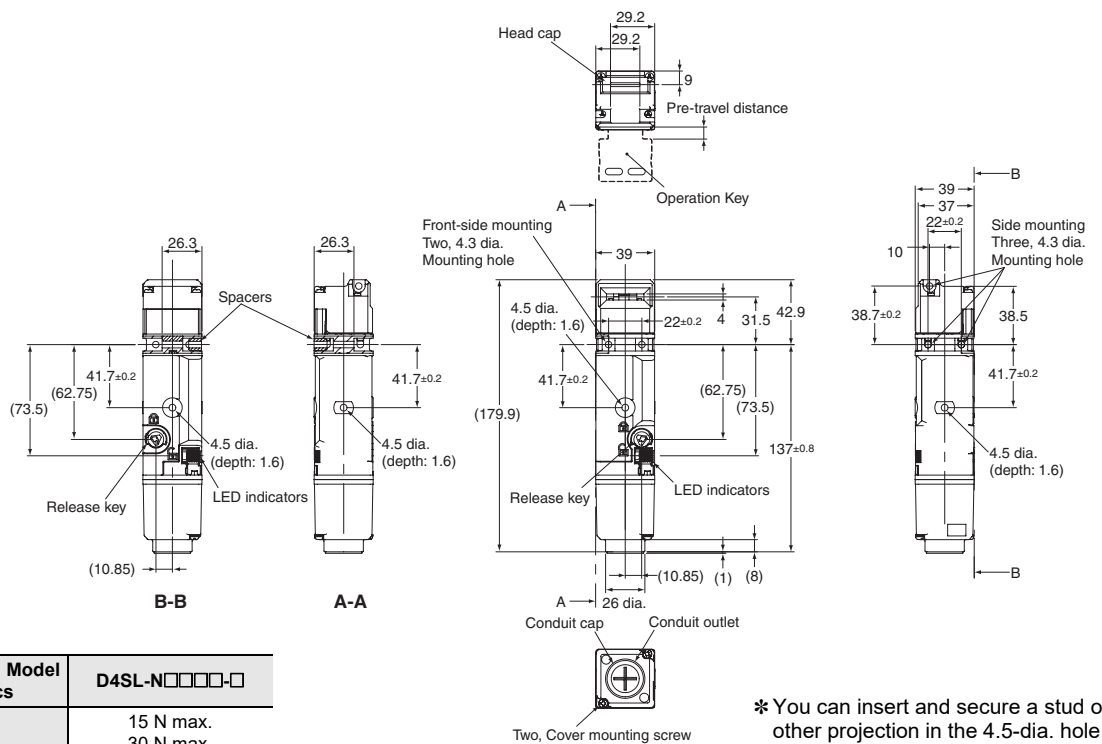

Model	D4SL-N□□□□-□
Operating characteristics	
Key insertion force	15 N max.
Key extraction force	30 N max.
Pre-travel distance	15 mm max.
Movement before being locked	3 mm min.

* You can insert and secure a stud or other projection in the 4.5-dia. hole to make the installation even stronger. For details, refer to "Switch and Operation Key Mounting" on page 24.

Note: Unless otherwise specified, a tolerance of ±0.4 mm applies to all dimensions.

Connector Cables

D4SL-CN

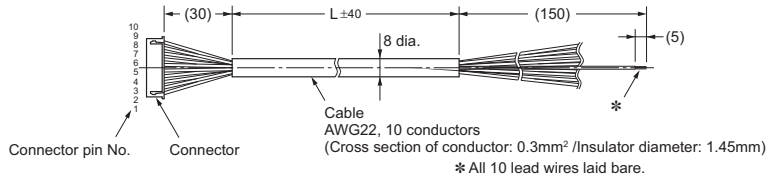

Model	L size
D4SL-CN1	1 m
D4SL-CN3	3 m
D4SL-CN5	5 m
D4SL-CN10	10 m

Connector No.	Lead wire color	Connector No.	Lead wire color
1	Black	6	Green/White
2	Black/White	7	Yellow
3	Red	8	Yellow/White
4	Red/White	9	Brown
5	Green	10	Brown/White

Slide Key

D4SL-NSK10-LK

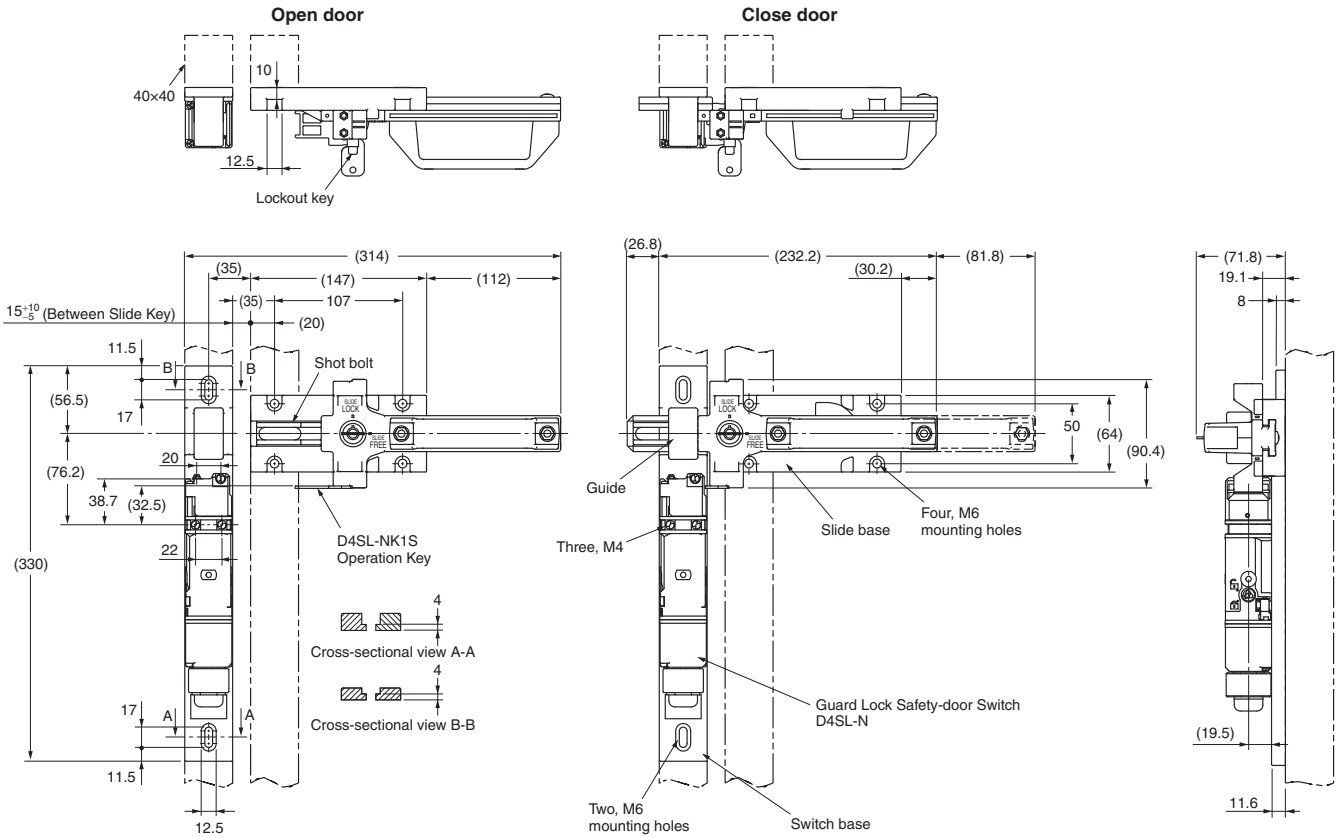

D4SL-N / D4SL-NSK10-LK□

D4SL-NSK10-LKH

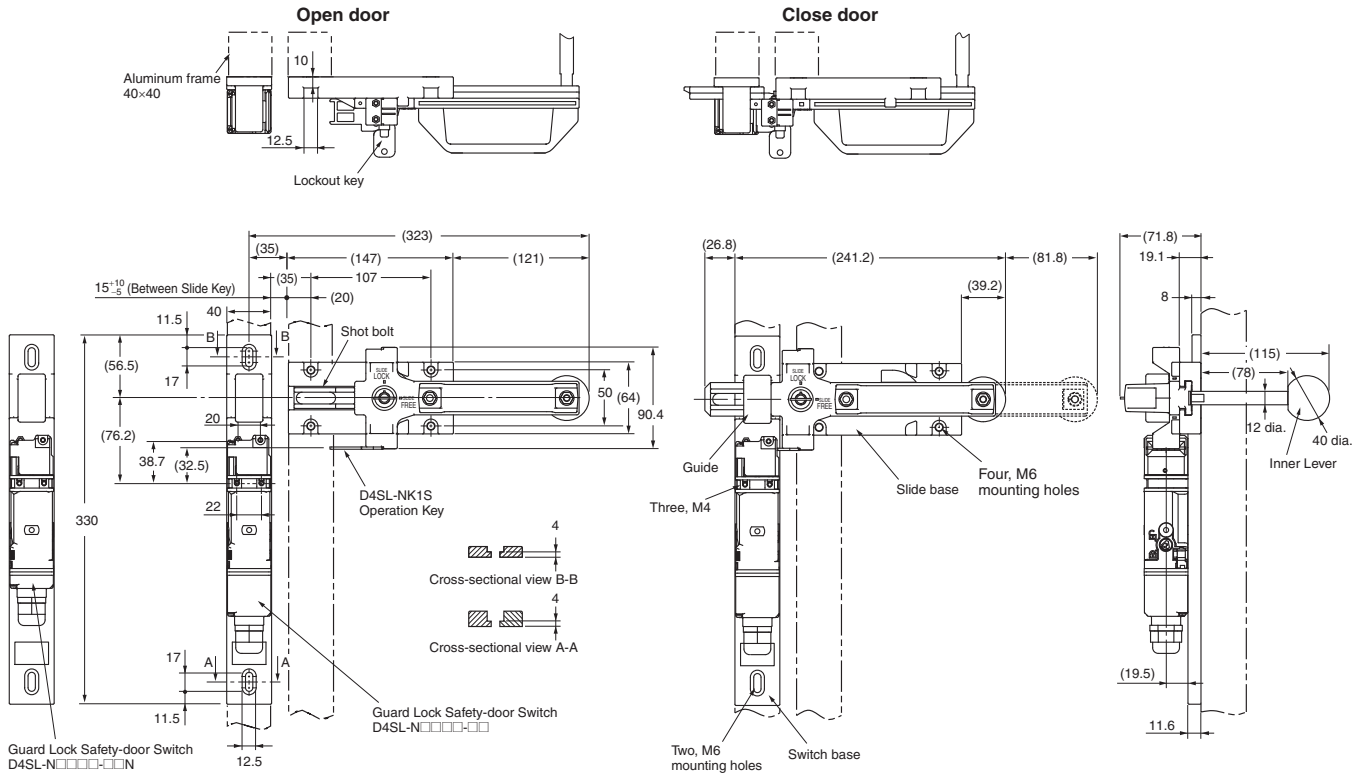

Accessory

M20-to-1/2-14NPT conversion adapter for D4SL-N3□□□□-□

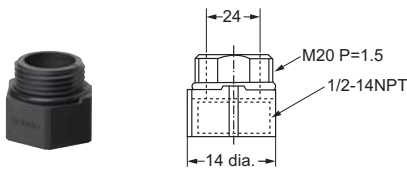

With Operation Key Inserted

D4SL-N + D4SL-NK1



With Front-inserted Operation Key

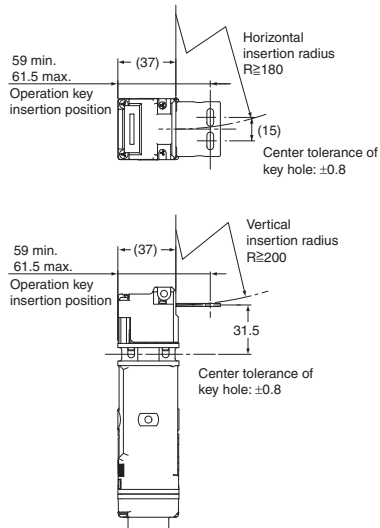

With Top-inserted Operation Key

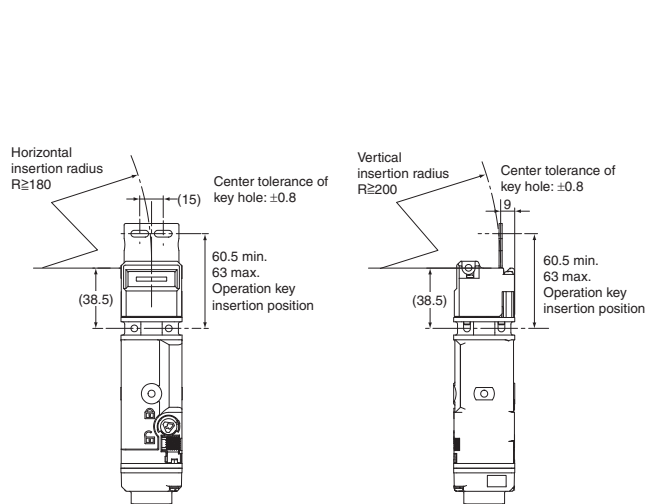

* Insertion radii apply when the rotational center of the Operation Key is in line with a line extending from the front or top Head surface.

D4SL-N + D4SL-NK1S



With Front-inserted Operation Key

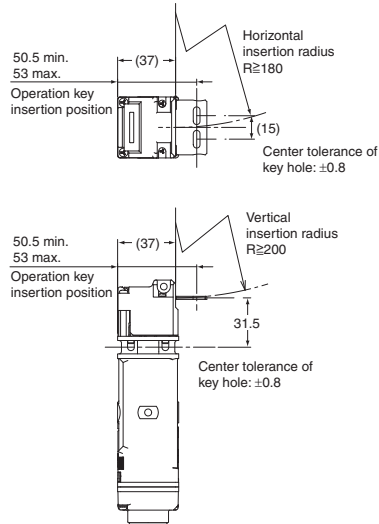

With Top-inserted Operation Key

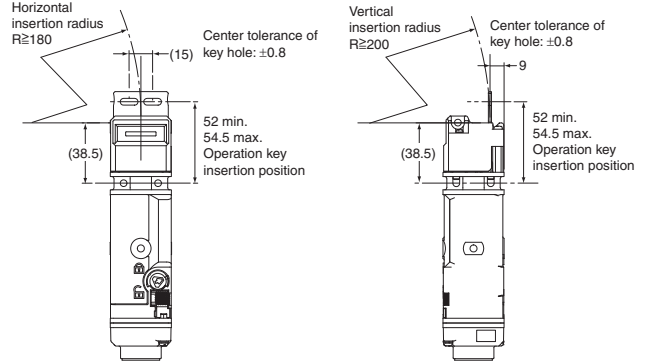

D4SL-N + D4SL-NK1G



With Front-inserted Operation Key

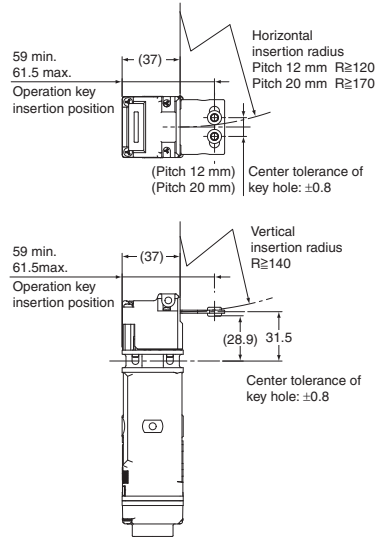

With Top-inserted Operation Key

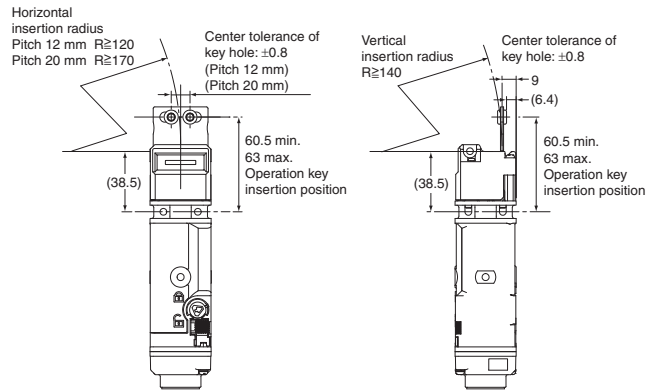

D4SL-N + D4SL-NK2



With Front-inserted Operation Key

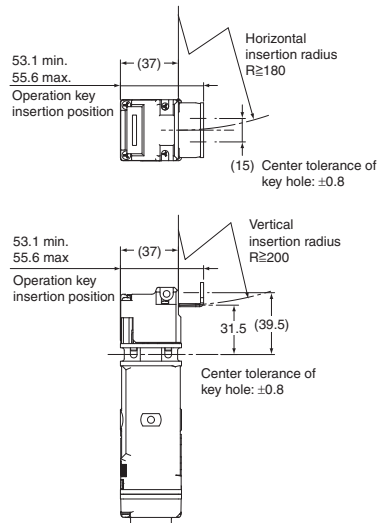

With Top-inserted Operation Key

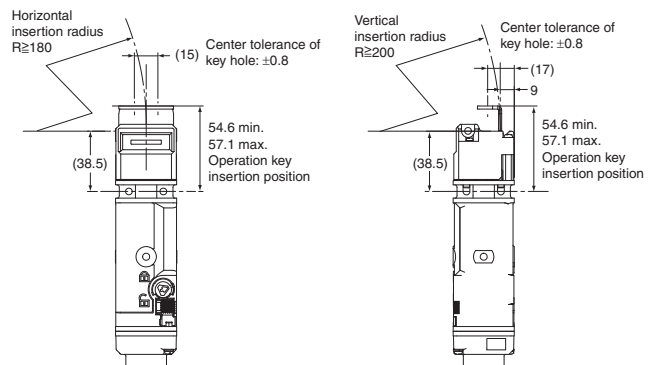

* Insertion radii apply when the rotational center of the Operation Key is in line with a line extending from the front or top Head surface.

D4SL-N / D4SL-NSK10-LK□

D4SL-N + D4SL-NK2G



With Front-inserted Operation Key

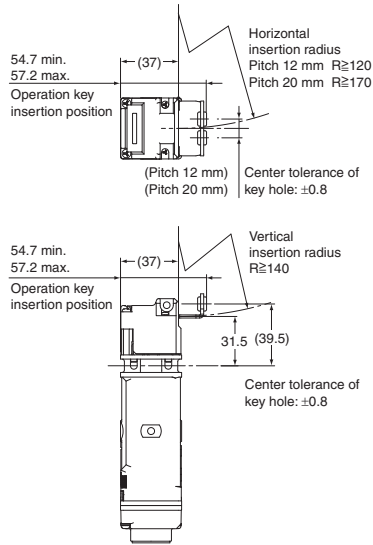

With Top-inserted Operation Key

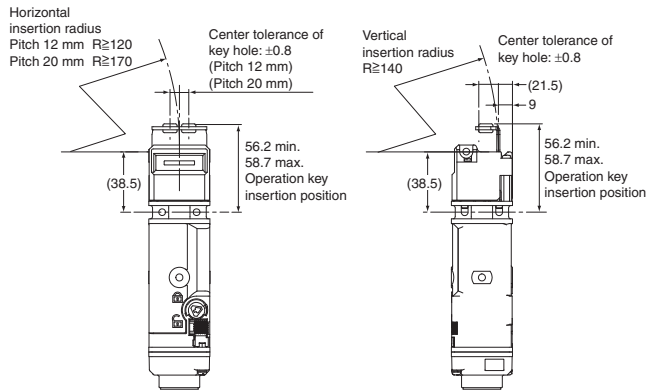

D4SL-N + D4SL-NK3



With Front-inserted Operation Key

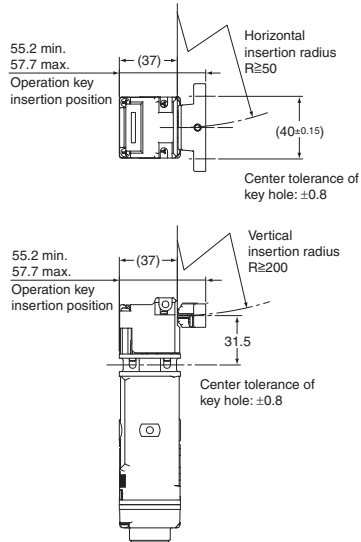

With Top-inserted Operation Key

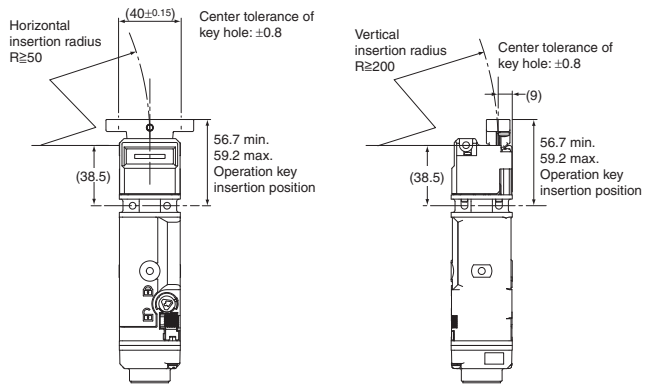

D4SL-N + D4SL-NK5



With Front-inserted Operation Key

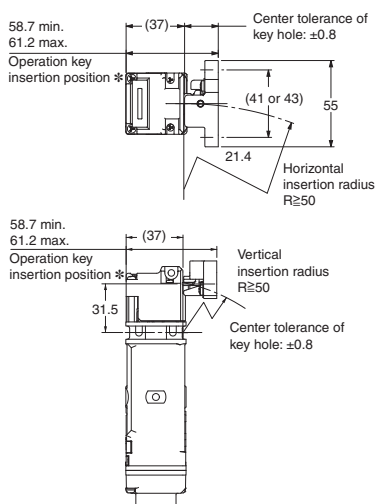

With Top-inserted Operation Key

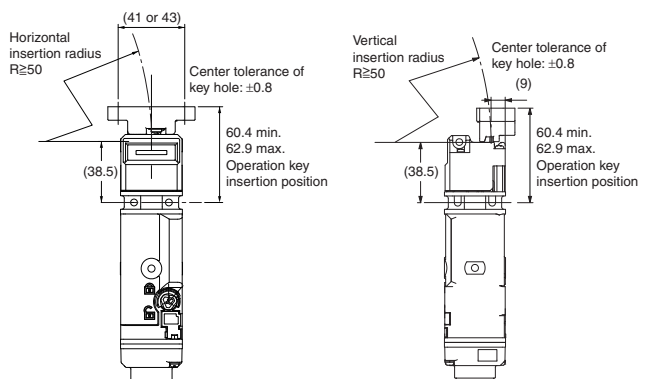

*1. Insertion radii apply when the rotational center of the Operation Key is in line with a line extending from the front or top Head surface.
 *2. If you use the D4SL-NK5 turned over, the operation key insertion position is 60.3 min. and 61.2 max.

Application Example

Highest achievable PL/ safety category	Model	Stop category	Reset
PLe/4 equivalent	Guard Lock Safety-door Switch D4SL-N□E□A-□ (Mechanical Lock Type) Safety Limit Switch D4N/D4F/D4B-N Safety Relay Unit G9SE-201 (24 VAC/VDC)	0	Manual

Note: The above PL is only the evaluation result of the example. The PL must be evaluated in an actual application by the customer after confirming the usage conditions.

● Application Overview

- After the opening of the guard is permitted by turning ON of the lock release enable signal, the guard is opened by operating the lock release switch S4.
- The guard status is monitored by the Safety Limit Switch S1 and Guard Lock Safety-door Switch S2, and a state in which the power supply to the motor M is turned OFF must be maintained while the guard is open.
- When the guard is closed, lock status is ensured, and the reset switch S3 is pressed, the power supply to the motor M is permitted.

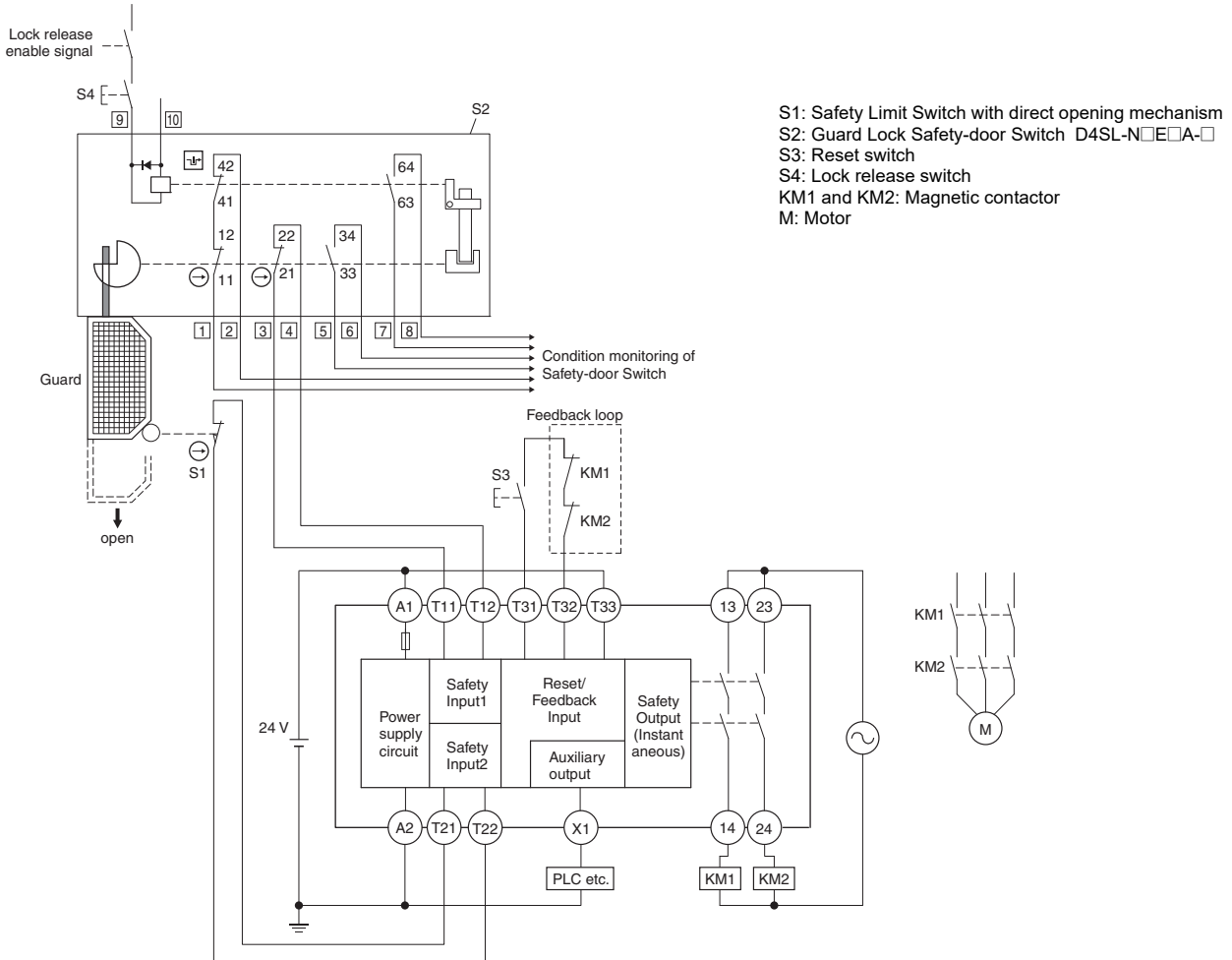

Timing Chart

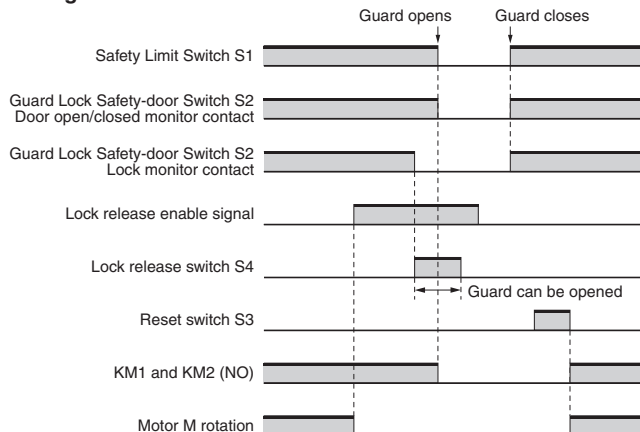

Note: The lock release enable signal must be configured so that it should turn ON after dangerous movement is stopped and safety is ensured for the door to open.

Safety Precautions

Be sure to read the precautions for **All Safety Door Switches** in the website at: <http://www.ia.omron.com/>.

⚠ DANGER	Indicates an imminently hazardous situation which, if not avoided, is likely to result in serious injury or may result in death. Additionally there may be severe property damage.
⚠ CAUTION	Indicates a potentially hazardous situation which, if not avoided, may result in minor or moderate injury or in property damage.
Precautions for Safe Use	Supplementary comments on what to do or avoid doing, to use the product safely.
Precautions for Correct Use	Supplementary comments on what to do or avoid doing, to prevent failure to operate, malfunction or undesirable effect on product performance.

⚠ DANGER

Injury may occasionally occur. Always check to make sure that the safety functions operate correctly before using the machine. The safety functions may not operate correctly because of wiring mistakes, setting mistakes, or Switch malfunction, causing some machines to continue operating in situations where they should be stopped. 

⚠ CAUTION

D4SL-N

Injury may occasionally occur. When the Switch function is damaged, some machines may continue operating in situations where they should be stopped. Do not impose a force exceeding the key holding force. Always provide a lock separate from the Switch, attach a warning seal to avoid excessive force applied to the Switch, or provide an indicator lamp to show the locked/unlocked status of the door. 

D4SL-NSK10-LK□

Do not use this product mounted so that it slides vertically. This may cause malfunction, resulting in personal injury. 

Do not insert the operation key with the door open. Devices may start to operate, resulting in injury. 

Precautions for Safe Use

D4SL-N
Operating Environment

Do not use the Switch submerged in oil or water or in locations continuously subject to splashes of oil or water. Doing so may result in oil or water entering the Switch. (The IP67 degree of protection of the Switch specifies the amount of water penetration after the Switch is submerged in water for a certain period of time.)

Wiring

- Do not switch circuits for three or more standard loads (125 VAC, 1A). Doing so may adversely affect insulation performance.
- Do not allow the load current to exceed the rated value.
- For metal cable glands, use a cable gland with the screw length of 9 mm or less. Otherwise it may result in electric shock.
- Do not use metal conduits. Damage to the conduit outlet may result in an improper seal or electric shock.
- Do not use metal cable gland for the conduit outlet of 1/2-14NPT. In the event of damage to the conversion adapter, this may cause seal failure and may result in electric shock.
- Always attach the cover after completing wiring and before using the Switch. Do not supply power when the cover is not attached. Electric shock may occur if the Switch is used without the cover attached.
- When using the terminal block type, make sure that foreign material does not adhere to the terminal block board. Otherwise a short circuit may occur between terminals and safety functions may fail to work properly.

Installation

- Make sure the Switch is mounted securely to prevent it from falling off. Otherwise injury may result.
- Do not use a Switch as a stopper. Be sure to install a stopper as shown in the following illustration so that the Operation Key does not touch the head. Do not subject the Switch to a shock that exceeds the Switch's shock resistance of 1,000 m/s².

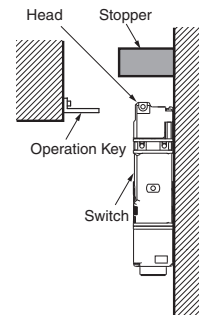

D4SL-NSK10-LK□

- Do not drop the Product. Doing so may prevent the Product from functioning to full capacity.
- Mount the Product securely to prevent it from falling. Otherwise, injury may occur.
- Do not attempt to disassemble or modify the Switch. Doing so may cause the Switch to malfunction.
- Make sure that the gap between the shot bolt and the guide is ±0.5 mm. Otherwise, excessive wear or damage may cause malfunction.
- To ensure safety, do not operate the Switch with anything other than the Slide Key Unit.
- Your hand may be injured by being pinched between the Operation Key and Switch when closing the door with your hand on the Product.

- Be careful to avoid pinching your hand when operating the Slide Handle.
- Do not impose a force of exceeding 1 N•m when operating the Lockout Key. Otherwise, the Product may be damaged and may not operate properly. To prevent damage, attach the supplied labels for display near the Product.
- Do not force the slide handle to move when the lockout key is not inserted. Doing so may damage the product and make operation impossible.
- Do not force the slide handle to move when the door is locked. Doing so may damage the product and make operation impossible.
- Do not close the door with the shot bolt removed. Doing so may damage the product and make operation impossible.
- Turn the Lockout Key to the "SLIDE LOCK" position and remove it when opening the door to prevent a third party from operating the Slide Handle.
- The durability of the Switch varies considerably depending on the switching conditions. Always confirm the usage conditions by using the Switch in an actual application, and use the Switch only for the number of switching operations given in the performance specifications.
- The user must not maintain or repair equipment incorporating the Switch. Contact the manufacturer of the equipment for any maintenance or repairs required.
- Refer to the *D4SL-N Guard Lock Safety-door Switch Instruction Sheet* about storage conditions, ambient conditions, Switch details, and handling methods.
- Do not apply excessive force in the direction of the slide. This may damage the product and cause it to malfunction.
- Do not force the switch or cable. This may damage the product. The cable should be fixed at a point separate from the switch.

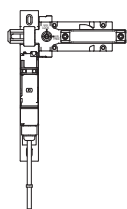

Precautions for Correct Use

D4SL-N Solenoid Lock Models

- For solenoid lock models, be sure to supply power to the solenoid after the door is closed (after the operation key is inserted). If the door is closed after power is supplied to the solenoid, locking the operation key may not be possible. (The solenoid carry current is applied for Approx. 10 seconds, after which the internal circuit switches to a constant current. The lock may not operate properly while the constant current is applied.)
- The solenoid lock locks the door only when power is supplied to the solenoid. Therefore, the door will be unlocked if the power supply to the solenoid stops. Therefore, do not use solenoid lock models for machines that may be operating and dangerous even after the machine stops operating.

Release Key

- The release key is used to unlock the Switch in case of emergency or if the power supply to the Switch stops.
- If the release key setting is changed from LOCK to UNLOCK, the lock will be released and the safety door can be opened (mechanical lock models only).

Front

D4SL-N□□□□□□□□

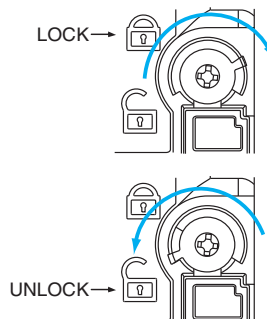

D4SL-N□□□□□□□4

D4SL-N□□□□□□□4

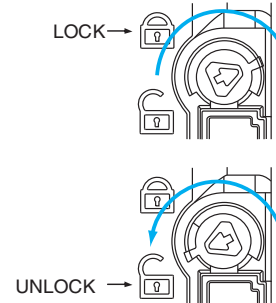

Back

D4SL-N□□□□□□□□

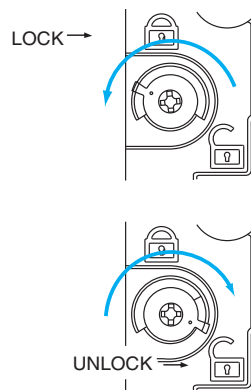

D4SL-N□□□□□□□4

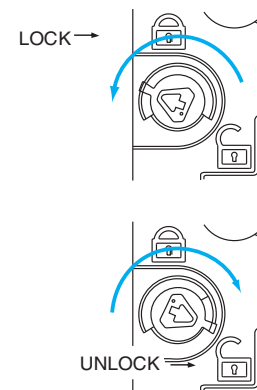

- When a Switch with a solenoid lock is in a locked state (i.e., when the solenoid is ON), do not change the release key from the LOCK to the UNLOCK position. Internal parts may be damaged.
- After setting the release key to UNLOCK to, for example, perform maintenance, be sure to return it to LOCK setting before resuming operation.
- The release key is set in the unlock position at the factory for the D4SL-N□□□□□□□A and to the lock position for the D4SL-N□□□□□□□G.
- In the unlock position, even when the door of large machines or stamping machines is closed during preliminary adjustment, the door will remain unlocked and the machines will not be activated.
- Do not use the release key to start or stop machines.
- The auxiliary lock must be released only by authorized personnel.
- Do not impose a force exceeding 0.2 N•m on the release key screws. The release key may be damaged and may not operate properly.
- To prevent the release key from being used by unauthorized personnel, set it to LOCK and seal it with sealing wax.

Mounting Covers

Confirm that the seal rubber has no defects before use. If the seal rubber is displaced or raised, or has foreign particles adhered to it, the sealing capability of the seal rubber will be adversely affected.

Hinged Door

- If the Switch is mounted too close to the hinge, the force imposed on the lock will be much larger than for locations far from the hinge and the lock may be damaged. Mount the Switch close to the handle.

Mounting

Appropriate Tightening Torque

Loose screws may result in malfunction. Be sure to tighten each screw of the Switch properly.

Cover mounting screw	0.4 to 0.5 N·m
Operation Key mounting screw	2.4 to 2.8 N·m (D4SL-NK□ and -NK□S)
	0.75 to 1.15 N·m (D4SL-NK□G)
Switch mounting screw	0.75 to 1.15 N·m
Cable gland	1.8 to 2.2 N·m (except 1/2-14NPT)
	1.4 to 1.8 N·m (1/2-14NPT)
Terminal screw	0.5 to 0.6 N·m (D4SL-N□□□□-□□)
* Terminal block type only	

Switch and Operation Key Mounting

- Mount the Switch and Operation Key securely to the applicable tightening torque with M4 screws. Always use washers.
- The switch can be fastened more firmly by a stud (4 mm dia., 1.5 mm max height) inserted from back side at the hole of the switch.

Switch mounting

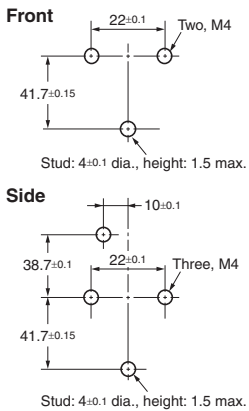

Operation Key mounting

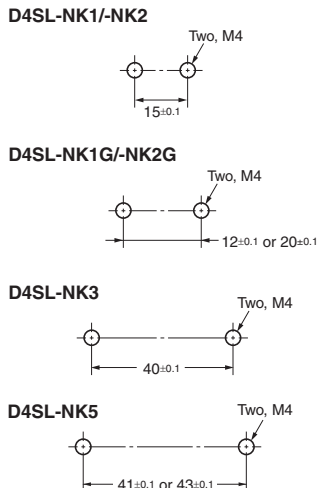

- Do not impose excessive force on the key top while the operation key is inserted into the switch body or drop the switch with the operation key inserted to avoid the deformation of the key or the breakage of the switch body.
- Do not use the operation key other than dedicated OMRON's (D4SL-NK□). Otherwise switch may be damaged.
- Do not use the operation key D4SL-K□. A lock will not be closed and a machine will not be activated.
- Be sure that the operation key can be inserted properly to key hole with a tolerance of ±0.8 mm.
- Insert the operation key into the key hole according to the specified "operation key insertion radius in horizontal direction".
- When mounting at the side of switch body, mount the switch with 3 points including the head.
- Attach cap heads to any operation key holes that are not being used.

Securing the Door

When the door is closed (with the Operation Key inserted), the Operation Key may exceed the set zone because of, for example, the door's own weight, machine vibration, or the door cushion rubber.

Secure the door with a stopper (hook) so that the Operation Key remains within the set zone.

- * If you use the D4SL-NK5 with the front key hole oriented in the direction shown in the right diagram, the set zone will be 2.1 to 3.0 mm.

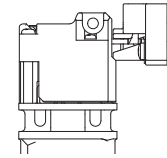
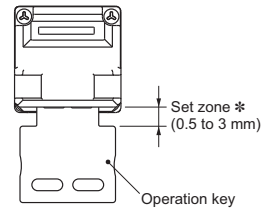

Spacer

Do not remove a spacer. Rotate the spacer in accordance with the Switch mounting direction. Use of the Switch without spacer will reduce the lock strength.

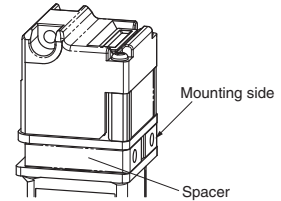
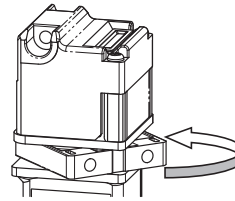

Wiring

- DC solenoids have polarity. (E1: +, E2: -) Confirm terminal polarity before wiring.
- The current of the 24 VDC solenoid is different from when it is first turned ON as to when it is in operation. To take into account possible voltage drops, it is important to apply a rated operation voltage.
- To enable the 24 VDC solenoid, it is necessary to select the appropriate power supply capacity.
- The ON and OFF contact operation will not engage simultaneously.
- Be sure to confirm operation under actual operating conditions.
- If a lock is required for safety, design the system so that the closing of the NC contacts on both the door open/closed detection switch and the lock monitor switch is detected.

Wiring Precautions for D4SL-N□□□□-□□

- Do not wire the Switch while power is being supplied. Doing so may result in electric shock.
- Do not let particles, such as small pieces of lead wire, enter the switch body when wiring.
- Do not directly wire the stranded wire to the terminal block.
- When connecting to the terminals via insulating tube and bar terminals, arrange the bar terminals so that they do not rise up onto the case or the cover.
- Applicable lead wire size: AWG22 to AWG18 (0.3 to 0.75 mm²).
- Use lead wires of an appropriate length. Not doing so may result in excess length causing the cover to rise and not fit properly.
- Remove the terminal block board out of the unit to perform wiring. Be sure to insert the connector properly.
- Do not pull on the lead wires with excessive force. Doing so may disconnect them.

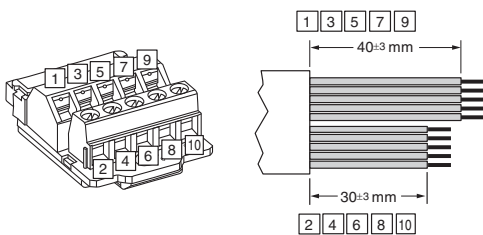

Recommended Crimp Terminals

Manufacturer	Model	Applicable wire lead
PHOENIX CONTACT	AI0.34-8 TQ	AWG22
	AI0.5-8 WH	AWG20
	AI0.75-8 GY	AWG18

L1: 14 mm max.

L2: 8 mm max.



Wiring Precautions for D4SL-N□□□□-□□N

- Do not wire the Switch while power is being supplied. Doing so may result in electric shock.
- Do not let particles, such as small pieces of lead wire, enter the switch body when wiring.
- Applicable lead wire size: AWG24 to AWG22 (0.2 to 0.3 mm²). Do not apply a current of 2 A or more when using AWG24.
- Use lead wires of an appropriate length. Not doing so may result in excess length causing the cover to rise and not fit properly.

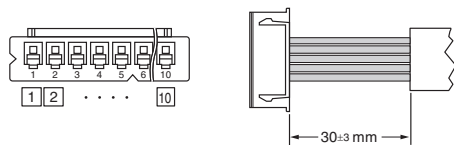

- Do not pull on the lead wires with excessive force. Doing so may disconnect them.

- Do not forcibly insert the wired socket at the cable side into the connector or D4SL-N's conduit outlet. Doing so may cause cable break.
Be sure to insert the cable into the connector or D4SL's conduit outlet before performing wiring to the socket, or insert the cable into the connector or conduit outlet from the opposite side of the socket.

Applicable socket for cable side

Manufacturer	Name	Model
J.S.T. Mfg Co.	Housing	XHP-10
	Contact (applicable wire lead: AWG24 to AWG22)	SXH-001T-P0.6

Processing the Conduit Outlet

- Use a recommended cable gland and tighten it with the appropriate tightening torque. The case may be damaged if an excessive tightening torque is applied.
- Use a cable conforming to the diameter of the cable gland to be used.
- For the 1/2-14NPT conduit, mount a provided conversion adapter and wrap the seal tape around it to use the cable gland.

Cable Gland

- Use a commercially available cable gland.
- Use a cable gland with a screw section not exceeding 9 mm to ensure wiring properties.

D4SL-N / D4SL-NSK10-LK□

D4SL-NSK10-LK□

- Use this product for a lightweight door (20 kg max). Otherwise the product may be damaged.
- This product is for D4SL-N Guard Lock Safety-door Switch only. This product cannot be used with any other manufacturer's door switches.
- Use the Slide Handle in the direction A or B in the following figure.

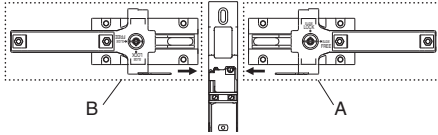

- Loose screws may result in malfunction. Use washers and tighten the screws to the specified torques. Mount the Slide Base at four points with screws. Adding adhesive is recommended for preventing the screws from loosening. Also, when mounting the Product to a door for disable-prevention purposes, purchase and use tamper-resistant screws.

Appropriate Tightening Torque

Slide Key mounting screw (M6)	6.0 to 7.0 N·m
Operation key special mounting screw (screws supplied)	2.4 to 2.8 N·m
Switch special mounting screw (screws supplied)	0.75 to 1.15 N·m
Inner Lever	9 to 10 N·m

Technical Specifications

Ambient operating temperature	-10 to 55°C (with no icing)
Ambient operating humidity	95% max.
Mechanical durability	20,000 operations min.

- Do not store the Switch where corrosive gases (e.g., H₂S, SO₂, NH₃, HNO₃ or Cl₂) or dust is present, or in locations subject to high temperature or humidity.
- Perform maintenance inspections periodically.
- When the lockout key is attached to your wrist, be careful that the strap does not get stuck in equipment.

Nomenclature

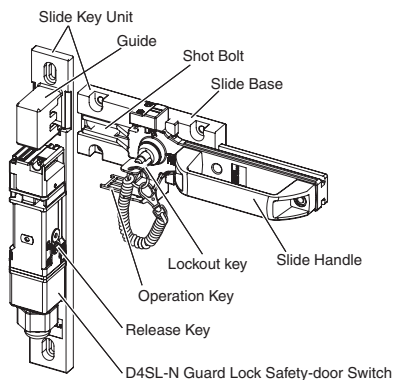

Differences between Lockout Key and Trapped Key (Reference)

	Lockout key	Trapped key (Refer to information on the D4JL-□□□A-□7-□□)
Closing the door	The door cannot be closed unless the lockout key is inserted in the slide and turned.	The door cannot be closed unless the trapped key is inserted in the Door Switch and turned.
Opening the door	The door can be opened by supplying power to the Door Switch solenoid without operating the lockout switch.	The door can never be opened without both supplying power to the Door Switch solenoid and operating the trapped key.

- When mounting the operation key, line up the inside edges of the long operation key holes with the outer edges of the slide handle as in the following figure to ensure easy position adjustment.

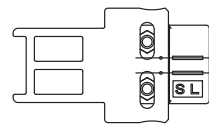

- Use the supplied special screws to mount the operation key and D4SL-N Guard Lock Safety-door Switch.
- To tighten the screws, use the tip of a flat-head screwdriver on the screw heads as shown in the following figure.

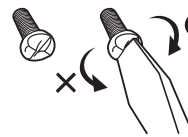

Note: The special screws are designed so that they cannot be turned counter-clockwise using a flat-head screwdriver.

- The special screws cannot be removed once they are tightened.

Mounting of inner lever

Mounting method

1) Detaching of mounting screw

Remove the handle mounting screw with TORX screwdriver (T30).

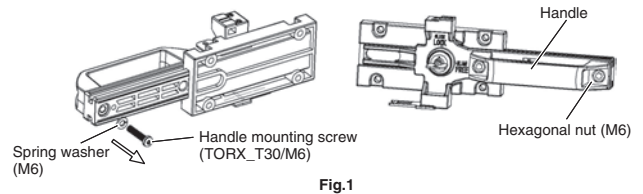

2) Mounting of inner lever

Tighten A portion of the inner lever to a suitable torque with wrench (width across flat: 10mm).

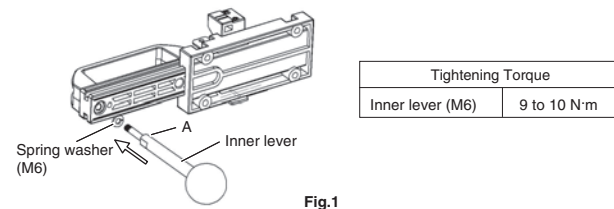

- This product is for Omron, the D4SL-NSK10 only. This product cannot be used with any other products.
- Do not operate the handle with the handle mounting screw removed. Doing so may result in malfunction.
- Be careful not to lose the spring washer and hexagonal nut when remove the handle mounting screw. (Fig.1)
- Loose inner lever may result in malfunction. Use washers and tighten the inner lever to the specified torque. (Fig.2)

Terms and Conditions Agreement

Read and understand this catalog.

Please read and understand this catalog before purchasing the products. Please consult your OMRON representative if you have any questions or comments.

Warranties.

- (a) Exclusive Warranty. Omron's exclusive warranty is that the Products will be free from defects in materials and workmanship for a period of twelve months from the date of sale by Omron (or such other period expressed in writing by Omron). Omron disclaims all other warranties, express or implied.
- (b) Limitations. OMRON MAKES NO WARRANTY OR REPRESENTATION, EXPRESS OR IMPLIED, ABOUT NON-INFRINGEMENT, MERCHANTABILITY OR FITNESS FOR A PARTICULAR PURPOSE OF THE PRODUCTS. BUYER ACKNOWLEDGES THAT IT ALONE HAS DETERMINED THAT THE PRODUCTS WILL SUITABLY MEET THE REQUIREMENTS OF THEIR INTENDED USE.

Omron further disclaims all warranties and responsibility of any type for claims or expenses based on infringement by the Products or otherwise of any intellectual property right. (c) Buyer Remedy. Omron's sole obligation hereunder shall be, at Omron's election, to (i) replace (in the form originally shipped with Buyer responsible for labor charges for removal or replacement thereof) the non-complying Product, (ii) repair the non-complying Product, or (iii) repay or credit Buyer an amount equal to the purchase price of the non-complying Product; provided that in no event shall Omron be responsible for warranty, repair, indemnity or any other claims or expenses regarding the Products unless Omron's analysis confirms that the Products were properly handled, stored, installed and maintained and not subject to contamination, abuse, misuse or inappropriate modification. Return of any Products by Buyer must be approved in writing by Omron before shipment. Omron Companies shall not be liable for the suitability or unsuitability or the results from the use of Products in combination with any electrical or electronic components, circuits, system assemblies or any other materials or substances or environments. Any advice, recommendations or information given orally or in writing, are not to be construed as an amendment or addition to the above warranty.

See <http://www.omron.com/global/> or contact your Omron representative for published information.

Limitation on Liability: Etc.

OMRON COMPANIES SHALL NOT BE LIABLE FOR SPECIAL, INDIRECT, INCIDENTAL, OR CONSEQUENTIAL DAMAGES, LOSS OF PROFITS OR PRODUCTION OR COMMERCIAL LOSS IN ANY WAY CONNECTED WITH THE PRODUCTS, WHETHER SUCH CLAIM IS BASED IN CONTRACT, WARRANTY, NEGLIGENCE OR STRICT LIABILITY.

Further, in no event shall liability of Omron Companies exceed the individual price of the Product on which liability is asserted.

Suitability of Use.

Omron Companies shall not be responsible for conformity with any standards, codes or regulations which apply to the combination of the Product in the Buyer's application or use of the Product. At Buyer's request, Omron will provide applicable third party certification documents identifying ratings and limitations of use which apply to the Product. This information by itself is not sufficient for a complete determination of the suitability of the Product in combination with the end product, machine, system, or other application or use. Buyer shall be solely responsible for determining appropriateness of the particular Product with respect to Buyer's application, product or system. Buyer shall take application responsibility in all cases.

NEVER USE THE PRODUCT FOR AN APPLICATION INVOLVING SERIOUS RISK TO LIFE OR PROPERTY OR IN LARGE QUANTITIES WITHOUT ENSURING THAT THE SYSTEM AS A WHOLE HAS BEEN DESIGNED TO ADDRESS THE RISKS, AND THAT THE OMRON PRODUCT(S) IS PROPERLY RATED AND INSTALLED FOR THE INTENDED USE WITHIN THE OVERALL EQUIPMENT OR SYSTEM.

Programmable Products.

Omron Companies shall not be responsible for the user's programming of a programmable Product, or any consequence thereof.

Performance Data.

Data presented in Omron Company websites, catalogs and other materials is provided as a guide for the user in determining suitability and does not constitute a warranty. It may represent the result of Omron's test conditions, and the user must correlate it to actual application requirements. Actual performance is subject to the Omron's Warranty and Limitations of Liability.

Change in Specifications.

Product specifications and accessories may be changed at any time based on improvements and other reasons. It is our practice to change part numbers when published ratings or features are changed, or when significant construction changes are made. However, some specifications of the Product may be changed without any notice. When in doubt, special part numbers may be assigned to fix or establish key specifications for your application. Please consult with your Omron's representative at any time to confirm actual specifications of purchased Product.

Errors and Omissions.

Information presented by Omron Companies has been checked and is believed to be accurate; however, no responsibility is assumed for clerical, typographical or proofreading errors or omissions.

Note: Do not use this document to operate the Unit.

OMRON Corporation Industrial Automation Company

Kyoto, JAPAN

Contact : www.ia.omron.com

Regional Headquarters

OMRON EUROPE B.V.

Wegalaan 67-69, 2132 JD Hoofddorp
The Netherlands
Tel: (31) 2356-81-300 Fax: (31) 2356-81-388

OMRON ELECTRONICS LLC

2895 Greenspoint Parkway, Suite 200
Hoffman Estates, IL 60169 U.S.A.
Tel: (1) 847-843-7900 Fax: (1) 847-843-7787

OMRON ASIA PACIFIC PTE. LTD.

438B Alexandra Road, #08-01/02 Alexandra
Technopark, Singapore 119968
Tel: (65) 6835-3011 Fax: (65) 6835-3011

OMRON (CHINA) CO., LTD.

Room 2211, Bank of China Tower,
200 Yin Cheng Zhong Road,
PuDong New Area, Shanghai, 200120, China
Tel: (86) 21-6023-0333 Fax: (86) 21-5037-2388

Authorized Distributor:

©OMRON Corporation 2012-2026 All Rights Reserved.
In the interest of product improvement,
specifications are subject to change without notice.

CSM_8_9

Cat. No. C146-E1-09 0726 (0412)