

General-purpose Laser Sensor Selection Guide

E3AS-HL / E3AS-HF / ZP-L

Laser Sensor Revolution Intuitive Sensor Installation and Setup



Excellent detection performance and usability

E3AS Series

CMOS Laser Sensor with Built-in Amplifier

E3AS-HL



Equivalent to Keyence LR-Z Series

Compact/Short distance
Sensing distance:
35 to 500 mm

Standard detectable difference
Min. 1 mm

Two-in-one performance
Two outputs standard

Less affected by color and surface
Line beam

TOF Laser Sensor with Built-in Amplifier

E3AS-HF



Equivalent to Keyence LR-T Series

Long distance
Sensing distance:
50 to 6000 mm

Standard detectable difference
Min. 5 mm

Stable with multiple sensors
Automatic Mutual Interference Prevention

Adjustable spot diameter
**Spot beam/
Diffused beam**

ZP-L Series

CMOS Laser Displacement Sensor with Separate Amplifier

ZP-L



Equivalent to Keyence IL Series

Inspection/detection:
10 μ m to 1 mm
Sensing distance:
20 to 1000 mm

Static resolution
0.5 μ m

Allowing quick test without loggers
Support software

Stable measurement of rough surfaces
Line beam

CMOS Laser Sensor (Triangulation method)

E3AS-HL **ZP-L**

The sensor uses diffuse reflected light from the workpiece. As the distance between the workpiece and the sensor changes, the light's position on the receiver shifts, enabling accurate distance measurement.

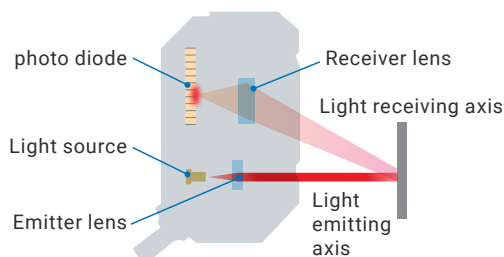





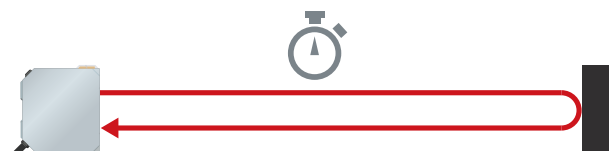

TOF Laser Sensor (Time of Flight)

E3AS-HF

The TOF (Time of Flight) method is a sensing principle that calculates distance by measuring the time it takes for emitted light to reflect off the workpiece and return to the receiver.



Presence Detection Built-in amplifier

Model	Sensing distance	Standard detectable difference	Beam shape
E3AS-HL150		35 to 50 mm: 1 mm 50 to 100 mm: 2 mm 100 to 150 mm: 4 mm	Spot beam 
E3AS-HL500		35 to 180 mm: 9 mm 180 to 300 mm: 18 mm 300 to 400 mm: 30 mm 400 to 500 mm: 45 mm	Line beam 
E3AS-HF6000		13 mm (default) 5 mm (Hysteresis: Manual setting 3 mm)	Spot beam  Diffused beam 

Displacement Differentiation Separate amplifier

Model	Sensing distance	Resolution *1	Beam shape
ZP-LS025		0.5 μm	Spot beam  Line beam 
ZP-LS050		0.7 μm	
ZP-LS100		1.2 μm	
ZP-LS300		4 μm	
ZP-LS600		14 μm	

Note: 1. Refer to page 15 for the amplifier unit of the ZP-L. *1. The resolution value refers to the line beam.

Outstanding Angle Characteristics that increase equipment design flexibility

E3AS-HL **E3AS-HF** **ZP-L**

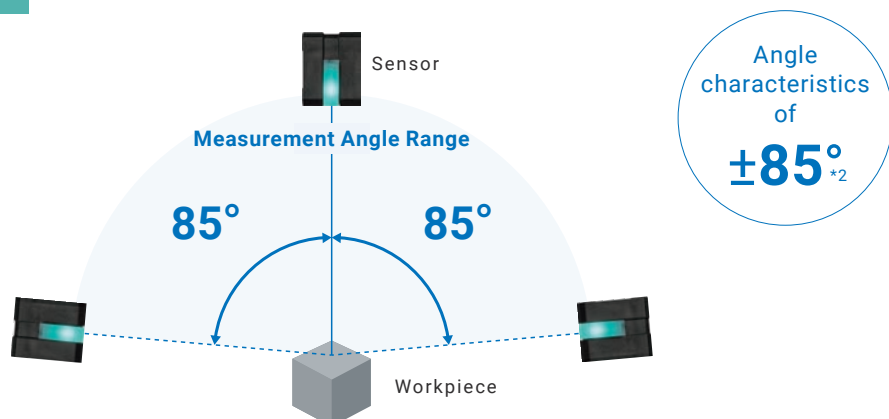

*2. Shape or material of measured object may impact measurement. Please check in advance using actual devices.

Applications

A lineup of general-purpose laser sensors for multiple applications.

STEP 1 What kind of detection do you have in mind?

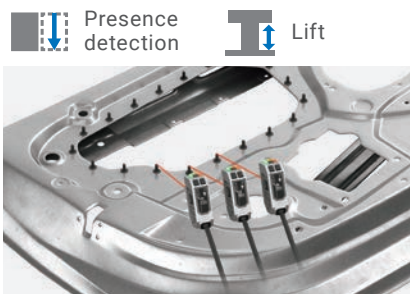
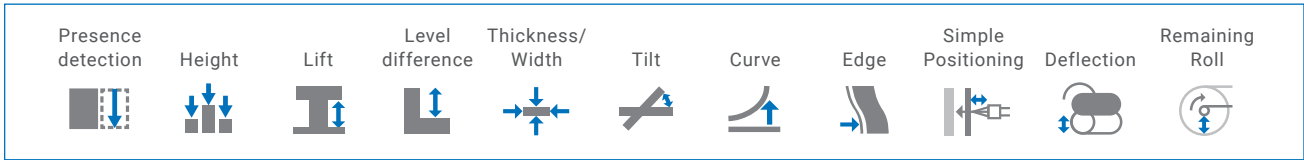

Presence detection of door parts

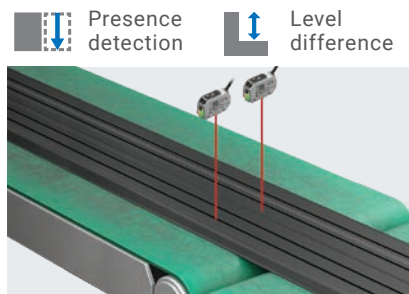

Presence detection of tires

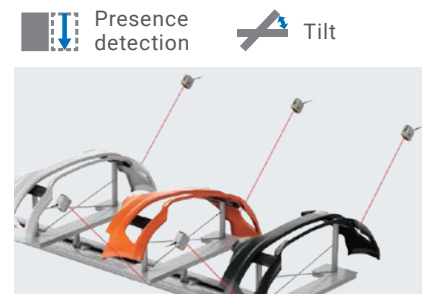

Bumper presence and tilt detection



Roll material remaining detection

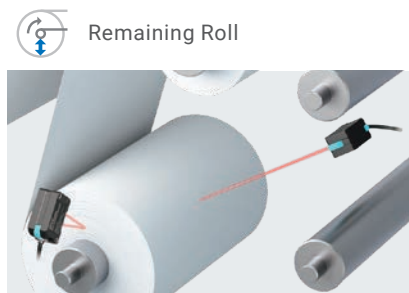

Electrode material remaining detection

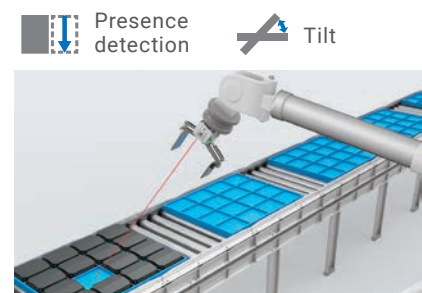

Battery component presence detection



Press stroke management

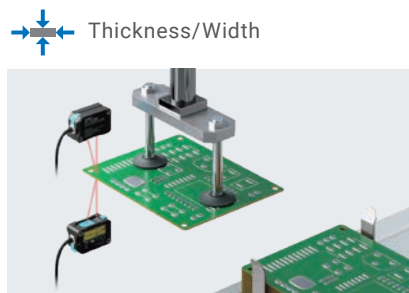

Checking for doubled-up boards

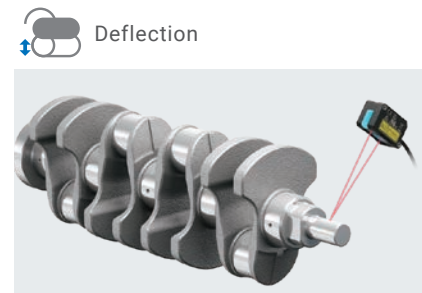

Crankshaft eccentricity measurement

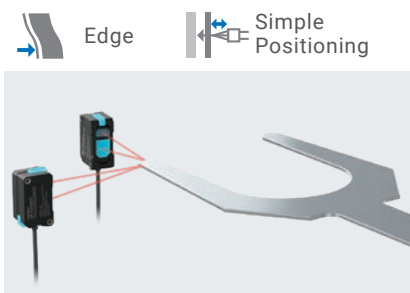

Robot hand positioning

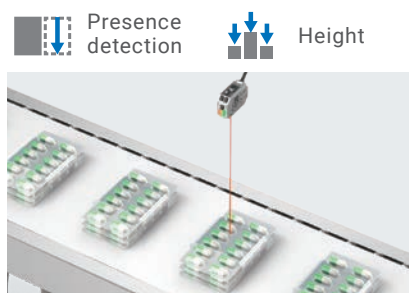

Tablet sheets count detection

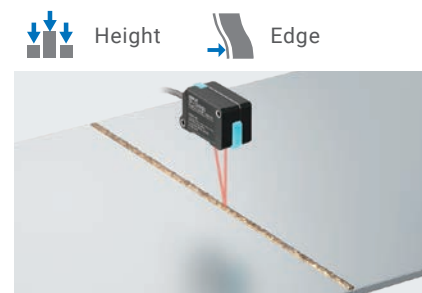

Detecting joints in welding

STEP 2

Choose the most suitable series according to the detection distance and standard detectable difference.

Presence Detection		Built-in amplifier	
Model	Sensing distance	Details page	Beam shape
E3AS-HL150		P. 7	Spot beam Line beam
[Standard detectable difference]			
E3AS-HL500		P.11	Spot beam Diffused beam
[Standard detectable difference]			

Displacement Differentiation		Separate amplifier	
Model	Sensing distance	Details page	Beam shape
ZP-LS025		P.15	Spot beam Line beam
[Standard detectable difference]			
ZP-LS050			
[Standard detectable difference]			
ZP-LS100			
[Standard detectable difference]			
ZP-LS300			
[Standard detectable difference]			
ZP-LS600			
[Standard detectable difference]			

Note 1: As ZP has no standard detectable difference definition, the value shown is 10 times the static resolution.

CMOS Laser Sensor with Built-in Amplifier

E3AS-HL Series

Conventional sensors have to be selected each time the shape, color, pattern, or reflectivity of the workpiece changes, so the equipment sometimes need to be redesigned. The E3AS-HL Series can detect workpieces without being significantly affected by variable shapes, colors, and materials, saving redesign time.

 **IO-Link** 



Reliable detection of workpieces with curved or irregular surfaces

With spot beam, detection is unstable since the reflected light does not reach the sensor depending on the profile of the workpiece surface. With the line beam of the E3AS-HL Sensor, detection is less affected by the profile of the surface since the reflected light reaches the sensor from any part of the surface.

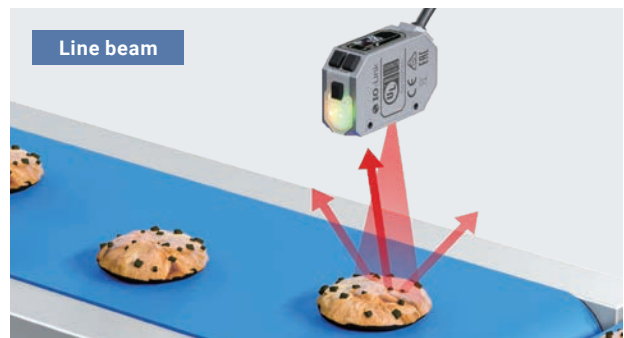

Install regardless of workpiece shape and angle

Curved surfaces of low-reflective workpieces tend to affect detection, and it is time consuming to design the mounting angle. E3AS-HL Sensors can be mounted at a wide angle, making setup easy.

*1. The reference values were measured using the OMRON standard sensing object.

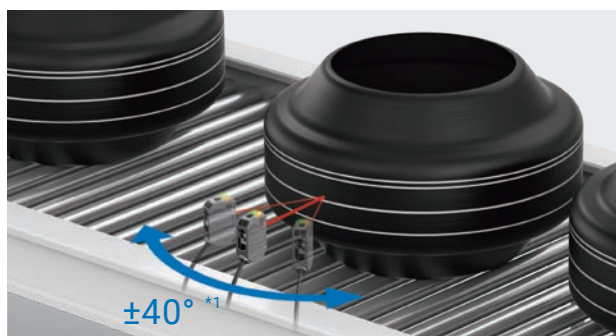

Background Reference Teaching (sensitive) capable of detecting transparent object detection



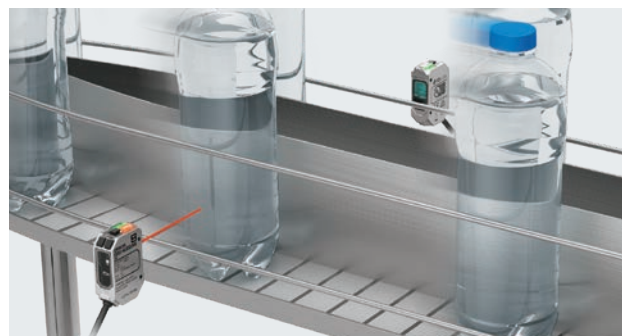

Previously, the setup of sensors for transparent objects required the experience and finesse of skilled workers, but it can now be done with just the press of a button. The E3AS-HL Sensor detects presence of workpieces from the variation (correlation) of background distance information and incident light level information.







Lineup

Line beam type

 Red laser

Connection method	Sensing distance (white paper)	Model		
		Output		PNP output COM3 (230.4 kbps)
		IO-Link baud rate	NPN output —	
Pre-wired (2 m) *1	 	500 mm	E3AS-HL500LMN 2M	E3AS-HL500LMT 2M
M8 Connector			E3AS-HL500LMN M3	E3AS-HL500LMT M3
M12 Pre-wired Smartclick Connector (0.3m) *2			E3AS-HL500LMN-M1TJ 0.3M	E3AS-HL500LMT-M1TJ 0.3M
Pre-wired (2 m) *1	 	150 mm	E3AS-HL150LMN 2M	E3AS-HL150LMT 2M
M8 Connector			E3AS-HL150LMN M3	E3AS-HL150LMT M3
M12 Pre-wired Smartclick Connector (0.3m) *2			E3AS-HL150LMN-M1TJ 0.3M	E3AS-HL150LMT-M1TJ 0.3M









Spot type

Connection method	Sensing distance (white paper)	Model		
		Output		PNP output COM3 (230.4 kbps)
		IO-Link baud rate	NPN output —	
Pre-wired (2 m) *1	 	500 mm	E3AS-HL500MN 2M	E3AS-HL500MT 2M
M8 Connector			E3AS-HL500MN M3	E3AS-HL500MT M3
M12 Pre-wired Smartclick Connector (0.3m) *2			E3AS-HL500MN-M1TJ 0.3M	E3AS-HL500MT-M1TJ 0.3M
Pre-wired (2 m) *1	 	150 mm	E3AS-HL150MN 2M	E3AS-HL150MT 2M
M8 Connector			E3AS-HL150MN M3	E3AS-HL150MT M3
M12 Pre-wired Smartclick Connector (0.3m) *2			E3AS-HL150MN-M1TJ 0.3M	E3AS-HL150MT-M1TJ 0.3M

*1. Models with 5-m cable length are also available with "5M" suffix. (Example: E3AS-HL500LMN 5M)

*2. M8 Pre-wired Connector Models are also available. When ordering, add "-M3J 0.3M" to the end of the model number (e.g., E3AS-HL500LMN-M3J 0.3M).

Option

Appearance	Model (material)	Appearance	Model (material)
L-shaped Mounting Bracket 	E39-L221 (SUS304)	Flexible Mounting Bracket 	E39-L261 *1 (SUS304)
Horizontal Protective Cover Bracket 	E39-L222 (SUS304)	Post 50 mm 	E39-L262
Rear Mounting Bracket 	E39-L223 (SUS304)	Post 100 mm 	E39-L263
Robust Mounting Bracket 	E39-L224 (SUS304)	Air Blow Unit 	E39-E16 *2
Front Protection Cover 	E39-E19	*1. The Flexible Mounting Bracket is not provided with a Post (E39-L262/ E39-L263). It must be ordered separately. *2. The tube for air is not included.	

Ratings and Specifications

Item	Model	Sensing method		Triangulation			
		NPN Output	E3AS-HL500MN	E3AS-HL500LMN	E3AS-HL150MN	E3AS-HL150LMN	
		PNP Output/COM3	E3AS-HL500MT	E3AS-HL500LMT	E3AS-HL150MT	E3AS-HL150LMT	
Sensing distance *1		35 mm to the set distance			35 mm to the set distance		
Setting range *1		35 to 500 mm			35 to 150 mm		
Standard detectable difference *1		35 to 180 mm: 9 mm 180 to 300 mm: 18 mm 300 to 400 mm: 30 mm 400 to 500 mm: 45 mm at 10 m sec			35 to 50 mm: 1 mm 50 to 100 mm: 2 mm 100 to 150 mm: 4 mm at 10 m sec		
Display minimum unit value		1 mm			0.1 mm		
Spot size (reference value) *2		2.5 mm × 1.5 mm at distance of 500 mm		18 mm × 1.5 mm at distance of 500 mm	2.5 mm × 1.3 mm at distance of 150 mm	8 mm × 1.3 mm at distance of 150 mm	
Light source (wavelength)		Red laser (660 nm)					
Laser class		Class 1 (JIS, IEC/EN, FDA, GB/T)					
Power supply voltage		10 to 30 VDC (including 10% ripple (p-p)), Class2					
Current consumption		100 mA max.					
Input/output	Control output	Load power supply voltage 30 VDC max. (Class2), the total load current of the two outputs is 100 mA max. Residual voltage (Load current 10 mA max.: 1 VDC max., Load current 10 to 100 mA: 2 VDC max.) Open-collector output (NPN/PNP output depending on model) N.O. (Normally Open) / N.C. (Normally Close) selectable					
		NPN	OUTPUT 1: NO (Normally open), OUTPUT 2: NC (Normally closed)				
	PNP/COM3	OUTPUT 1: NO (Normally open)/COM□, OUTPUT 2: NC (Normally closed)					
	External input	Laser OFF / Teaching / Zero reset selectable NPN ON time: 0 V short-circuit or 1.5 V or less, OFF time: Power supply voltage short-circuit or open PNP ON time: Power supply voltage short-circuit or within power supply voltage - 1.5 V, OFF time: 0 V short-circuit or open					
Indicators		OLED Display (White), Power/Communication indicator (Green*), Operation indicator (Orange) * IO-Link Communication mode: blinking					
Protection circuits		Power supply reverse polarity protection, Output short-circuit protection, and Output reverse polarity protection					
Response time		1.5 ms / 10 ms / 50 ms selectable					
Threshold setting method		Teaching method / Manual Operations / IO-Link communications					
Mutual interference prevention		4 units max. (when using the mutual interference prevention function)					
Ambient illumination		Receiver surface illuminance: Incandescent lamp: 20,000 lx max., Sunlight: 25,000 lx max. at distance of 250 mm Incandescent lamp: 5,000 lx max., Sunlight: 10,000 lx max. at distance of 500 mm			Receiver surface illuminance: Incandescent lamp: 8,000 lx max., Sunlight: 16,000 lx max.		
Ambient temperature range		Operating: -10 to 50°C, Storage: -25 to 70°C (with no icing or condensation)					
Ambient humidity range		Operating: 35% to 85%, Storage: 35% to 95% (with no condensation)					
Insulation resistance		20 MΩ min. at 500 VDC					
Dielectric strength		1,000 VAC, 50/60 Hz for 1 min					
Vibration resistance		10 to 55 Hz with a 1.5-mm double amplitude for 2 hours each in X, Y, and Z directions					
Shock resistance		500 m/s ² for 3 times each in X, Y, and Z directions					
Degree of protection		IP67 (IEC60529) and IP67G *3 (JIS C 0920 Annex 1), IP69K (ISO20653)					
Connection method		Pre-wired (standard cable length: 2 m), M8 Connector, M12 Pre-wired Smartclick Connector (standard cable length: 0.3m)					
Weight (packed state/ Sensor only)	Pre-wired (2 m)	Approx. 180 g/approx. 110 g					
	M8 Connector	Approx. 120 g/approx. 50 g					
	M12 Pre-wired Smartclick Connector (0.3 m)	Approx. 150 g/approx. 80 g					
Materials	Case	Stainless steel (SUS316L)					
	Lens cover and Display	Methacrylic resin (PMMA) (Lens cover: Antifouling coating)					
	Indicator	Polyamide 11 (PA11)					
Main IO-Link functions		Operation mode switching between NO and NC, execution of teaching (2-point teaching, Background teaching), setup of the threshold, timer function of the control output and timer time selecting, Restore Factory Settings, Key Lock (Unlock, Lock, Lock (No Button)), monitor output (Detection level, Incident light level)					
IO-Link Communication specifications	IO-Link specification	Ver. 1.1					
	Baud rate	COM3 (230.4 kbps)					
	Data length	PD size: 4 bytes, OD size: 1 byte (M-sequence type: TYPE_2_V)					
	Minimum cycle time	COM3: 1.2 ms					
Accessories		Instruction manual, compliance sheet, index list (attached for IO-Link type only) FDA certification label and Warning label Note: Mounting Brackets must be ordered separately.					

*1. Measured with OMRON's standard workpiece (White ceramic).

*2. Defined by D4σ method at the maximum sensing distance. Detection may be influenced if there is light leakage outside the defined region and the surroundings of the target object have a high reflectance in comparison to the target object. Also, when detecting a workpiece that is smaller than the spot size, a correct value may not be obtained.

*3. The IP67G is the degree of protection which is defined according to the JIS (Japanese Industrial Standards). The IP67 indicates the same level of protection as defined by the IEC, and the G indicates that a device has resistance to oil.

For details, refer to E3AS-HL/F/L Series Catalog for the automotive industry (No. E594) or E3AS-HL/F/L Series Catalog for the food and commodity industry (No. E595).

Dimensions

Sensors

Pre-wired Models/Pre-wired Connector Models

E3AS-HL500□(-M1TJ)
E3AS-HL150□(-M1TJ)

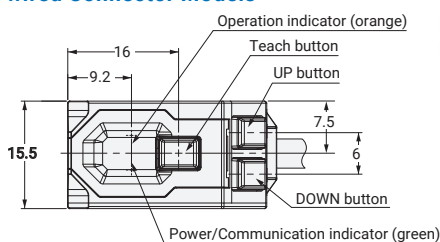

Connector Models

E3AS-HL500□ M3
E3AS-HL150□ M3

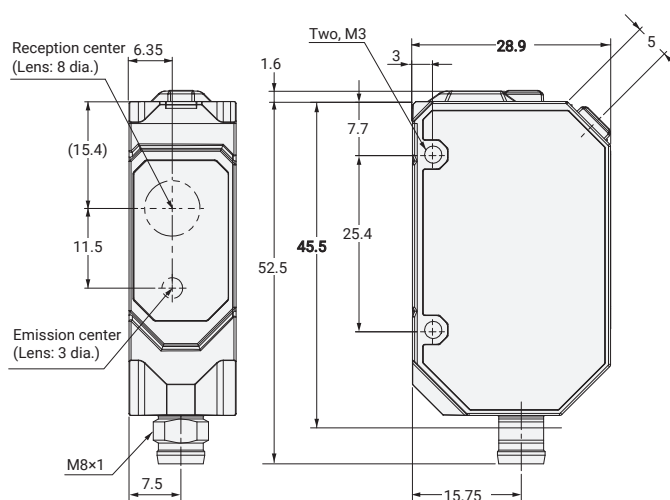
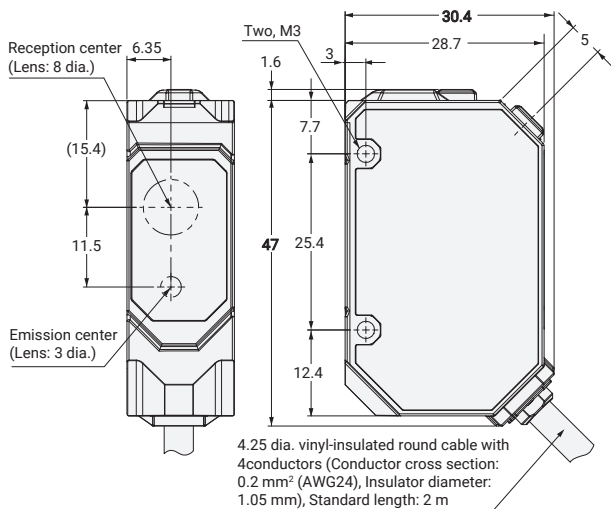
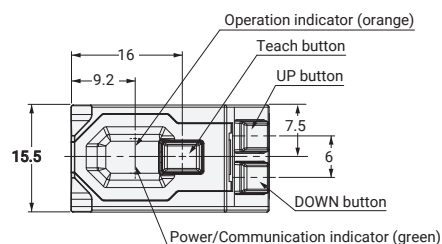

Pre-wired Connector Models
E3AS-HL500□-M1TJ
E3AS-HL150□-M1TJ

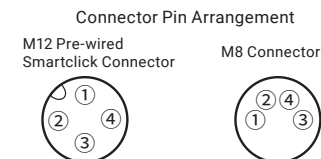
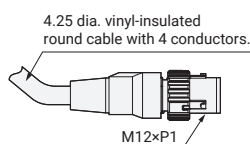

Input/Output circuit

NPN output

Using Pin2 (white wire) as output

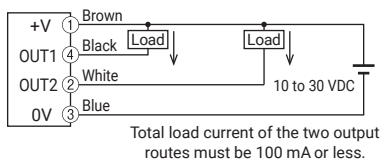

Using Pin2 (white wire) as external input

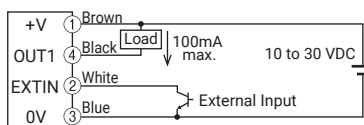

External Input	NPN
ON time	0V short-circuit or 1.5V or less
OFF time	Power supply voltage short-circuit or open

PNP output

Standard I/O mode (SIO mode) *1

Using Pin2 (white wire) as output

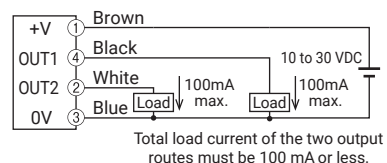

Using Pin2 (white wire) as external input

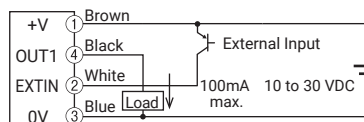

External Input	PNP
ON time	Power supply voltage short-circuit or within power supply voltage - 1.5V
OFF time	0V short-circuit or open

IO-Link Communication mode (COM mode) *2

Using Pin2 (white wire) as output

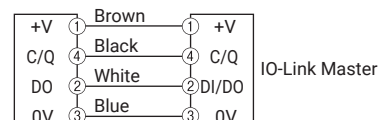

*1. Standard I/O mode is used as PNP ON/OFF output.

*2. IO-Link Communication mode is used for communications with the IO-Link Master. C/Q performs IO-Link communications. Sensor output DO performs ON/OFF output.

TOF Laser Sensor with Built-in Amplifier

E3AS-HF Series

Performance of conventional long-distance reflective photoelectric sensors is not always stable since their detection performance varies with the colors and shapes of detected objects. With its unique sensing algorithm, E3AS-HF has overcome the problem, eliminating the time and effort to select and set up sensors.

 **IO-Link** 

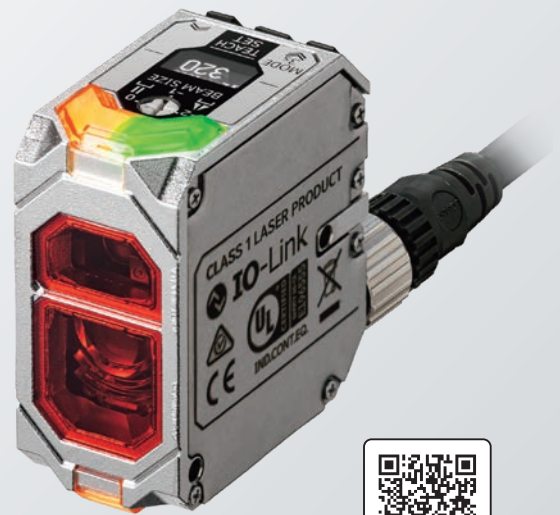

A wide sensing range and excellent angle characteristics supported at the same time

A sensing range of 0.05 to 6 m and angle characteristics of $\pm 85^\circ$ max.

Place the sensors away from the pathways of people and robots so that the sensors do not obstruct their movement. Thus remove failure risks such as optical axis displacement and cable disconnection due to collision with a workpiece, and ensure stable sensing when the target workpiece is changed or added.

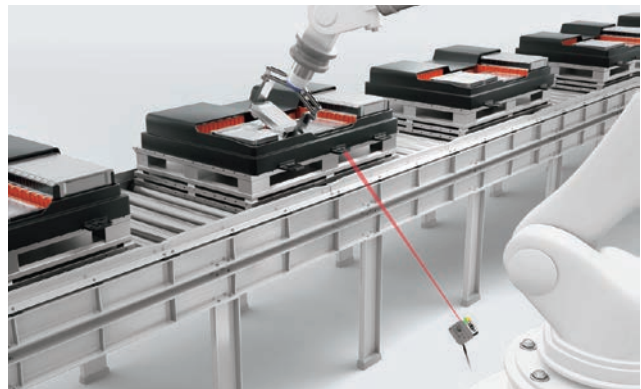

Automatic Mutual Interference Prevention

The technology adopted by E3AS-HF can prevent interference between the sensors without the need for their channel settings. It prevents the sensors are mounted adjacent to each other from causing mutual interference, reducing equipment disruptions.

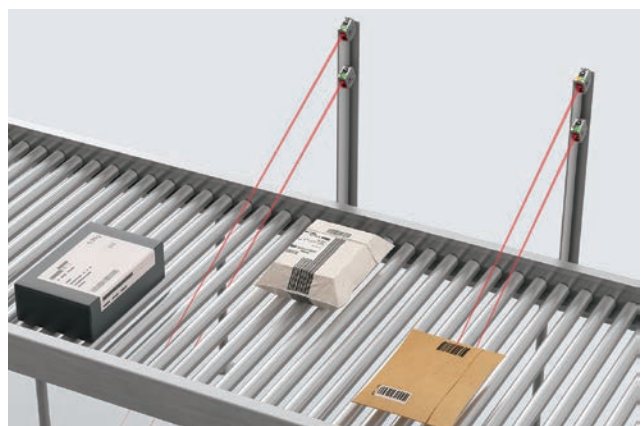

Spot diameter adjustable for the workpiece

The spot diameter adjustable with the dial on the top of the sensor can be selected from three options according to whether you want to detect a spot on a small workpiece such as a pin or an area on a surface such as a hole.

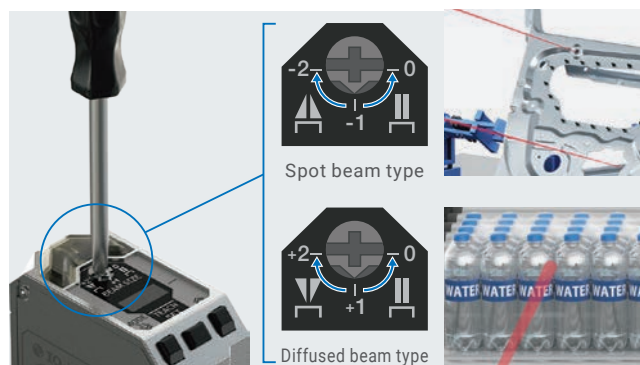

Lineup

Spot beam type

 Red laser

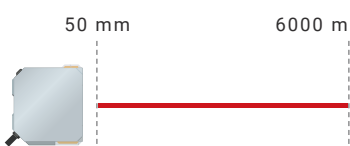



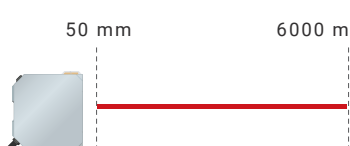

Connection method	Sensing distance	Model		
		Output	NPN output	PNP output
		IO-Link baud rate	--	COM3 (230.4 kbps)
Pre-wired (2 m) *1			E3AS-HF6000SMN 2M	E3AS-HF6000SMT 2M
M12 Connector (horizontal)			E3AS-HF6000SMN M1H	E3AS-HF6000SMT M1H
M12 Connector (vertical)			E3AS-HF6000SMN M1V	E3AS-HF6000SMT M1V
M12 Pre-wired Smartclick Connector (0.3 m)			E3AS-HF6000SMN-M1TJ 0.3M	E3AS-HF6000SMT-M1TJ 0.3M

Diffused beam type

Connection method	Sensing distance	Model		
		Output	NPN output	PNP output
		IO-Link baud rate	--	COM3 (230.4 kbps)
Pre-wired (2 m) *1			E3AS-HF6000DMN 2M	E3AS-HF6000DMT 2M
M12 Connector (horizontal)			E3AS-HF6000DMN M1H	E3AS-HF6000DMT M1H
M12 Connector (vertical)			E3AS-HF6000DMN M1V	E3AS-HF6000DMT M1V
M12 Pre-wired Smartclick Connector (0.3 m)			E3AS-HF6000DMN-M1TJ 0.3M	E3AS-HF6000DMT-M1TJ 0.3M

*1. Models with 5-m cable length are also available with "5M" suffix. (Example: E3AS-HF6000SMN 5M)

Option

Appearance	Model	Appearance	Model
L-shaped Mounting Bracket (180°) 	E39-L245	Post 100 mm 	E39-L263
L-shaped Mounting Bracket (360°) 	E39-L255	Air Blow Unit *2, *3 	E39-E17
Flexible Mounting Bracket *1 	E39-L264	Front Protection Cover 	E39-E20
Post 50 mm 	E39-L262		

*1. The Flexible Mounting Bracket is not provided with a Post (E39-L262/ E39-L263). It must be ordered separately.

*2. When using the Air Blow Unit (E39-E17), use the L-shaped Mounting Bracket (E39-L245).

*3. The tube for air is not included.

Ratings and Specifications

Item	Sensing method		TOF (Time of flight)	
	Model	Type	Spot beam type	Diffused beam type
		NPN Output	E3AS-HF6000SMN <input type="checkbox"/>	E3AS-HF6000DMN <input type="checkbox"/>
	PNP Output	E3AS-HF6000SMT <input type="checkbox"/>	E3AS-HF6000DMT <input type="checkbox"/>	
Sensing distance	50 to 6,000 mm			
Beam size	Variable (Parallel / Spot)		Variable (Parallel / Diffusion, used with 40 dia. or less)	
Light source (wavelength)	Red laser (660 nm)			
Power supply voltage	10 to 30 VDC, (including ripple (p-p) 10%), Class2			
Consumption current *1	65 mA max. (when power voltage is 24 V), 155 mA max. (when power voltage is 10 V). Note: 125 max. at environment below the freezing point (when power voltage is 24 V)			
Control output	Load power supply voltage 10 to 30 VDC (Class2), Load current 100 mA max. each output (total of 2 outputs is 200 mA max.) Residual voltage (Load current 10 mA max.: 1 VDC max., Load current 10 to 100 mA: 2 VDC max.) Open collector output type (Depends on the NPN/PNP output type) NO/ NC selectable			
Current output	4 to 20 mA, maximum load resistance 500 Ω			
External input	Laser OFF / Teaching / Zero reset selectable NPN ON time: 0 V short-circuit or 1.5 V or less (Outflow current: 1 mA or less) OFF time: Power supply voltage short-circuit or open PNP ON time: Power supply voltage short-circuit or within power supply voltage - 1.5 V (Sink current: 1 mA or less) OFF time: 0 V short-circuit or open			
Protection circuits	Reversed power polarity protection, Output short-circuit protection and Output reverse polarity protection			
Indicator	OLED Display (White), Power/Communication indicator (Green), Operation indicator (Orange), and Bottom indicator (Green, Orange)			
Response time	2 ms / 10 ms / 50 ms / 200 ms selectable			
Setting method of threshold level	Teaching method / Manual Operations / IO-Link communications			
Mutual interference prevention	Auto setting (Manual setting is also possible: up to 4 units)			
Ambient illumination	Incandescent lamp / Sunlight: 100,000 lx max.			
Ambient temperature	Operating: -30 to 55°C (with no icing or condensation) *2, Storage: -30 to 70°C (with no icing or condensation)			
Ambient humidity	Operating: 35 to 85%, Storage: 35 to 95%RH (with no condensation)			
Insulation resistance	20 MΩ min. at 500 VDC			
Dielectric strength	1,000 VAC at 50 / 60 Hz for 1 min			
Vibration resistance	10 to 55 Hz, 1.5-mm double amplitude for 2 hours each in X, Y, and Z directions			
Shock resistance	500 m/s ² for 3 times each in X, Y, and Z directions			
Enclosure ratings	IP67 (IEC60529), IP69K (ISO20653), IP67G (JIS C 0920 Annex 1) *3			
Weight (packed state/Sensor only)	Pre-wired (2 m)	Approx. 280 g/approx. 167 g		
	M12 Connector (horizontal/vertical)	Approx. 223 g/approx. 114 g		
	M12 Pre-wired Smartclick Connector (0.3 m)	Approx. 237 g/approx. 128 g		
Material	Case	Aluminum die cast (Chrome plating)		
	Cover	SUS304		
	Indicator	Polyethersulfone (PES)		
	Lens cover and Display	Methacrylic resin (PMMA), Antifouling coating (Lens cover)		
IO-Link Communication specifications	IO-Link specification	Ver. 1.1		
	Baud rate	COM3: 230.4 kbps		
	Data length	PD size: 4 bytes, OD size: 2 byte (M-sequence type: TYPE_2_V)		
	Minimum cycle time	COM3: 1.2 ms		
	Device profile	Smart Sensor Profile (SSP4.1.1) Identification and Diagnosis (I&D)		
Conformity standards	UL/CSA Certification, CE Marking, RCM, UKCA, Ecolab, RoHs2, WEEE2			
MTTF _D *4	340 year			
Accessories	Instruction manual, compliance sheet, index list (attached for IO-Link type only), FDA certification label Note: Mounting Brackets must be ordered separately.			

Note: 1. Altitude: Up to 2000 m, Pollution degree: 3, Enclosure type: Type1.

*1. Excluding load current.

*2. When the product is used in an environment with a temperature of -10°C or less, a warm-up time (10 min maximum) is required.

*3. JIS C 0920 Annex 1 describes the IP67G rating oil and the oil resistance of the product has been assessed by the document.

Please visit the website of the Japanese Industrial Standards for more information. (<https://www.jisc.go.jp/index.html>)

*4. The MTTFD value is for reference only and does not guarantee product lifetime. It is calculated as MTTFD = MTTF × 2.

For details, refer to E3AS-HF Series Catalog (No. E626).

Dimensions

Sensors

Pre-wired Models/Pre-wired Connector Models

E3AS-HF6000 □ (-M1TJ)

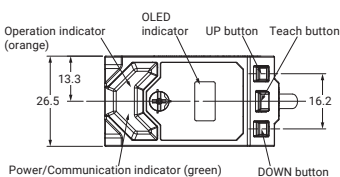

M12 Connector (horizontal)

E3AS-HF6000 □ M1H

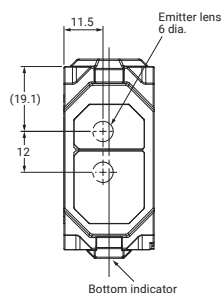
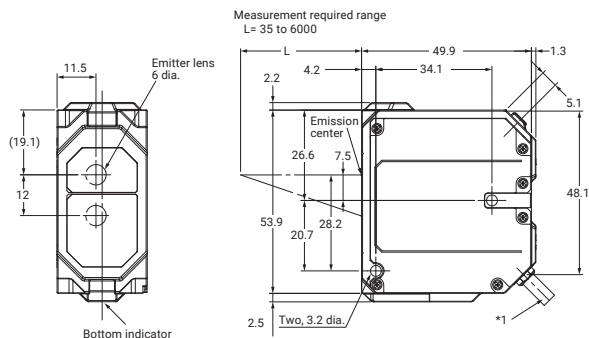
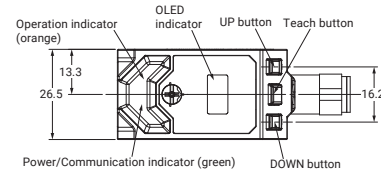

M12 Pre-wired Smartclick Connector Models

E3AS-HF6000 □ -M1TJ

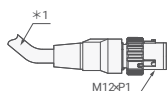

M12 Connector (vertical)

E3AS-HF6000 □ M1V

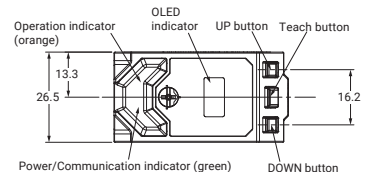

*1. Specification of the cable

Model	Specification	Number of cores	Length
E3AS-HF6000 □ 2M	PVC Cable: 4.25 dia. Conductor cross section: 0.2 mm ² Insulator diameter: 1.05 mm	1. Brown: +V 2. White: Output 2 3. Blue: 0V 4. Black: Output 1	2 M
E3AS-HF6000 □ 5M			5 M
E3AS-HF6000 □ -M1TJ 0.3M		PIN No.1: +V PIN No.2: Output 2 PIN No.3: 0V PIN No.4: Output 1	0.3 M

Connector Pin Arrangement
M12 Pre-wired Smartclick Connector
M12 Connector

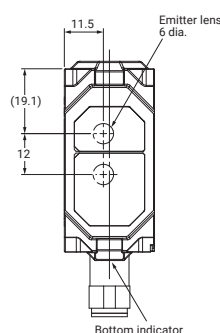

Input/Output circuit

NPN output

Using Pin2 (white wire) as output

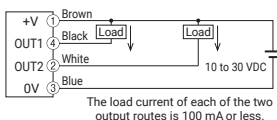

Using Pin2 (white wire) as external input

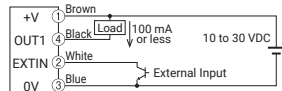

External Input	PNP
ON time	0 V short-circuit or 1.5 V or less (Outflow current: 1 mA or less)
OFF time	Power supply voltage short-circuit or open

Using Pin2 (white wire) as current

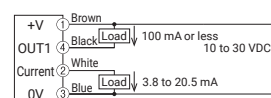

PNP output

Standard I/O mode (SIO mode) *1
Using Pin2 (white wire) as output

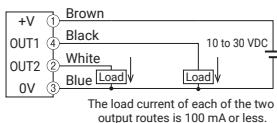

Using Pin2 (white wire) as external input

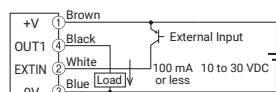

External Input	PNP
ON time	Power supply voltage short-circuit or within power supply voltage - 1.5 V (Sink current: 1 mA or less)
OFF time	0 V short-circuit or open

Using Pin2 (white wire) as current *3

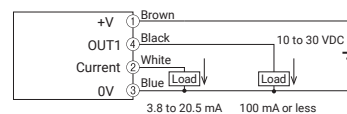

IO-Link Communication mode (COM mode) *2

Using Pin2 (white wire) as output

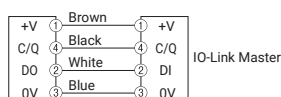

Using Pin2 (white wire) as current *3

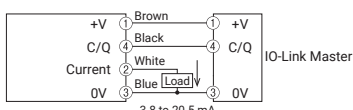

*1. Standard I/O mode is used as PNP ON/OFF output.

*2. IO-Link Communication mode is used for communications with the IO-Link Master. C/Q performs IO-Link communications. Sensor output DO performs ON/OFF output.

*3. Switch Pin2 setting to "Current" before wiring. There is a risk of a load short-circuit error.

Laser Displacement Sensor with Separate Amplifier

ZP-L Series

ZP-L Series products are equipped with a carefully designed user interface, as well as detection accuracy. They're packed with creative features that allow engineers to cut back on time and effort unknowingly spent when working with displacement sensors.



Sensing performance delivering stable detection with initial configuration left intact

ZP-L delivers a wide dynamic range*1 that delivers stable detection of a wide range of workpieces, from black polished workpieces (such as the painted surface of a car body), which reflect little light, to metal workpieces, which reflect a lot of light.

*1. "Dynamic range" is a metric that indicates the range of detectable workpiece types, expressed as the ratio between the reflectance of the most reflective detectable workpiece and that of the least reflective detectable workpiece.

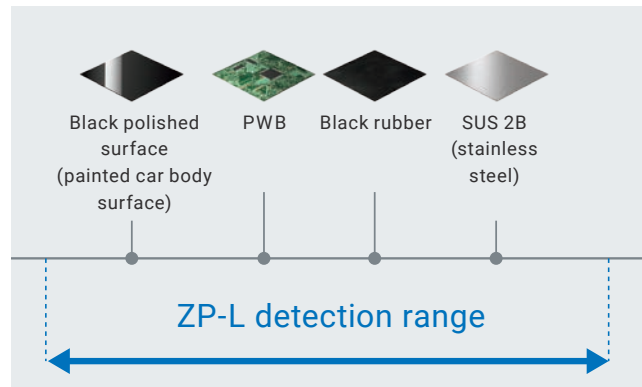

User interface requiring no manuals for easy understanding

ZP-L amplifier units are equipped with OLED displays, which are capable of much richer presentation, allowing for easy-to-understand menu displays that save you the time of searching through your manuals for the right page.

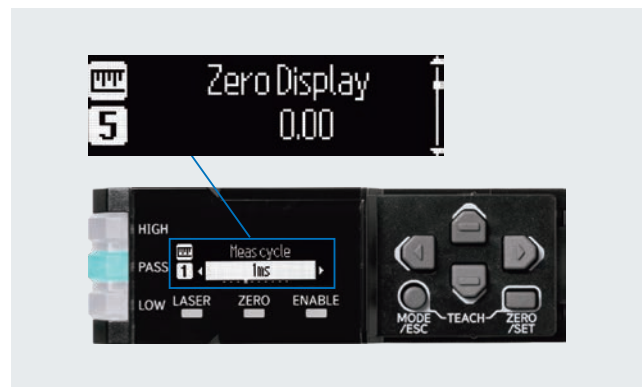

Support software allowing quick test without loggers



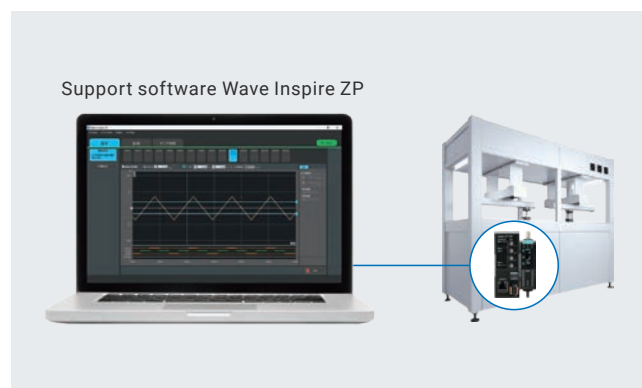



With ZP-L, you can check sensor conditions without impacting the equipment's control operations, just by connecting the PC with the support software Wave Inspire ZP installed to the switching hub. There's no need for data loggers, or to program PLCs for operation checks. The support software Wave Inspire ZP can be downloaded for free.

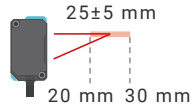
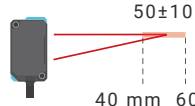
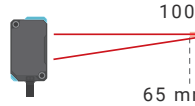

Lineup

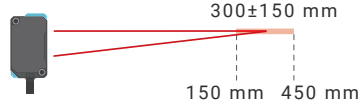
Sensor Head

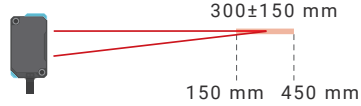





 Red laser

Appearance	Optical system	Measurement distance	Beam shape	Resolution *	Cable length	Model
	Diffuse-reflective	 25±5 mm 20 mm 30 mm	Line beam	0.5 μm	0.2 m	ZP-LS025L 0.2M
			Spot beam		2 m	ZP-LS025L 2M
		 50±10 mm 40 mm 60 mm	Line beam	0.7 μm	0.2 m	ZP-LS050L 0.2M
			Spot beam		2 m	ZP-LS050L 2M
		 100±35 mm 65 mm 135 mm	Line beam	1.2 μm	0.2 m	ZP-LS100L 0.2M
			Spot beam		2 m	ZP-LS100L 2M
	Diffuse-reflective	 300±150 mm 150 mm 450 mm	Line beam	4 μm	0.2 m	ZP-LS300L 0.2M
			Spot beam		2 m	ZP-LS300L 2M
		 600±400 mm 200 mm 1000 mm	Line beam	14 μm	0.2 m	ZP-LS600L 0.2M
			Spot beam		2 m	ZP-LS600L 2M
		 300±150 mm 150 mm 450 mm	Line beam	4 μm	0.2 m	ZP-LS300S 0.2M
			Spot beam		2 m	ZP-LS300S 2M
 600±400 mm 200 mm 1000 mm	Line beam	14 μm	0.2 m	ZP-LS600S 0.2M		
	Spot beam		2 m	ZP-LS600S 2M		

* This shows the width of the variation of measured values when OMRON's standard target (white diffuse object) is measured at a reference distance with a measurement cycle of 1 ms and an average rate of 128 times.

Note: Sensor heads listed on this data sheet use class 2 lasers, but we offer products with class 1 lasers as well, the model names of which end with the letter "C" followed by cable length (example: ZP-LS025LC 2M).

Amplifier Unit

Appearance	Master/Slave *1	Analog output	Judgment output *2	External input *3	Input/output type	Model
	Master unit	Yes	Yes	Yes	NPN	ZP-L3000
		No	Yes	Yes	PNP	ZP-L3050
	Slave unit	Yes	Yes	Yes	NPN	ZP-L3010
		No	Yes	Yes	PNP	ZP-L3060
	Slave unit	Yes	Yes	Yes	NPN	ZP-L3500
		No	Yes	Yes	PNP	ZP-L3550
	Slave unit	No	No	No	—	ZP-L3510
	Slave unit	No	No	No	—	ZP-L3560
	Slave unit	No	No	No	—	ZP-L3590

*1. First amplifier unit must be master unit.

In a system with multiple amplifier units connected together, there can only be one master unit.

Power supply connection is required for master unit only. All power supplied to slave and communication units is supplied from master unit.

*2. HIGH/PASS/LOW

*3. Zero reset, LD-off, timing, reset, bank

Option

Communication Unit

Appearance	Communication type	Connected devices	Model
	EtherNet/IP™ No-protocol (TCP)	PLCs and PCs from different manufacturers	ZP-EIP
	RS-232C	PLCs and PCs from different manufacturers	ZP-RSA

To use support software Wave Inspire ZP connect your sensor to your PC using the communication unit.

Wave Inspire ZP can be downloaded for free from the URL below.

https://www.ia.omron.com/zp_tool

Wave Inspire ZP is a setup support tool. Please note the following before use.

- (1) OMRON assumes no responsibility for damage caused by any malfunctioning of this software, whether directly or indirectly, or caused by the effects of such malfunctioning.
- (2) OMRON assumes no responsibility for any damage incurred by the customer due to use of this software.

Mounting bracket

Appearance	Illustration of installed bracket	Model	
		For ZP-LS025/-LS050/-LS100	For ZP-LS300/-LS600
L-shaped Mounting Bracket 		ZP-XL1	ZP-XL3
Rear Mounting Bracket 		ZP-XL2	ZP-XL4
Flexible Mounting Bracket 		ZP-XL5	ZP-XL6
Post 50 mm 		E39-L262	E39-L262
Post 100 mm 		E39-L263	E39-L263

Sensor head - amplifier unit extension cable

Cable connection direction	Cable length	Model	
		Normal cable	Robot cable
Amplifier unit side: Straight Sensor head side: Straight	1 m	XS3W-M421-401-R	XS3W-M421-401-PR
	2 m	XS3W-M421-402-R	XS3W-M421-402-PR
	5 m	XS3W-M421-405-R	XS3W-M421-405-PR
	10 m	XS3W-M421-410-R	XS3W-M421-410-PR
	20 m	XS3W-M421-420-R	XS3W-M421-420-PR
Amplifier unit side: L-shaped Sensor head side: L-shaped	1 m	XS3W-M422-401-R	XS3W-M422-401-PR
	2 m	XS3W-M422-402-R	XS3W-M422-402-PR
	5 m	XS3W-M422-405-R	XS3W-M422-405-PR
	10 m	XS3W-M422-410-R	XS3W-M422-410-PR
	20 m	XS3W-M422-420-R	XS3W-M422-420-PR
Amplifier unit side: Straight Sensor head side: L-shaped	1 m	XS3W-M423-401-R	XS3W-M423-401-PR
	2 m	XS3W-M423-402-R	XS3W-M423-402-PR
	5 m	XS3W-M423-405-R	XS3W-M423-405-PR
	10 m	XS3W-M423-410-R	XS3W-M423-410-PR
	20 m	XS3W-M423-420-R	XS3W-M423-420-PR
Amplifier unit side: L-shaped Sensor head side: Straight	1 m	XS3W-M424-401-R	XS3W-M424-401-PR
	2 m	XS3W-M424-402-R	XS3W-M424-402-PR
	5 m	XS3W-M424-405-R	XS3W-M424-405-PR
	10 m	XS3W-M424-410-R	XS3W-M424-410-PR
	20 m	XS3W-M424-420-R	XS3W-M424-420-PR

Recommended EtherNet/IP Communications Cables

Item	Normal cable		Robot cable	
	Cable length	Model	Cable length	Model
Cable with Connectors on Both Ends (RJ45/RJ45) EtherNet/IP (10BASE/100BASE) 	0.3 m	XS6W-6PUR8SS30CM-YF	0.3 m	XS5W-T421-AMD-K
	0.5 m	XS6W-6PUR8SS50CM-YF	0.5 m	XS5W-T421-BMD-K
	1 m	XS6W-6PUR8SS100CM-YF	1 m	XS5W-T421-CMD-K
	2 m	XS6W-6PUR8SS200CM-YF	2 m	XS5W-T421-DMD-K
	3 m	XS6W-6PUR8SS300CM-YF	5 m	XS5W-T421-GMD-K
	5 m	XS6W-6PUR8SS500CM-YF	10 m	XS5W-T421-JMD-K

Amplifier Unit Wiring

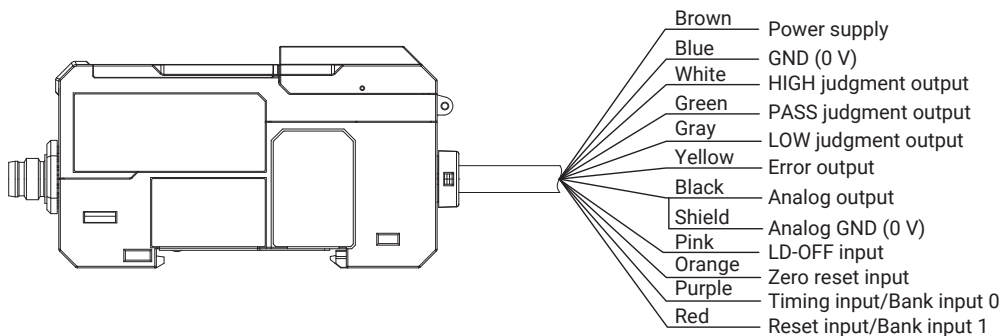

ZP-L3010/ZP-L3060 does not have black (analog output/GND).

ZP-L3500/ZP-L3550 does not have brown (power supply) and blue (GND).

ZP-L3510/ZP-L3560 does not have black (analog output/GND), brown (power supply), and blue (GND).

ZP-L3590 does not have power supply or input/output lines.

Sensor Head

Item	Specification						
	ZP-LS025L(C)	ZP-LS025S(C)	ZP-LS050L(C)	ZP-LS050S(C)	ZP-LS100L(C)	ZP-LS100S(C)	
Reference distance	25 mm		50 mm		100 mm		
Measurement distance	20 to 30 mm		40 to 60 mm		65 to 135 mm		
Light source	Red semiconductor laser						
Wavelength	660 nm						
Laser class	ZP-LS□L, ZP-LS□S: Class 2 (JIS/IEC/EN/FDA/GB) ZP-LS□LC, ZP-LS□SC: Class 1 (JIS/IEC/EN/FDA/GB)						
Laser power	ZP-LS□L, ZP-LS□S: 1 mW max. ZP-LS□LC, ZP-LS□SC: 0.376 mW max.						
Spot diameter *1	Approx. 50 × 1,000 μm	Approx. 50 μm dia.	Approx. 70 × 1,600 μm	Approx. 70 μm dia.	Approx. 130 × 2,900 μm	Approx. 120 μm dia.	
Linearity *2	Near side	±0.05% F.S. (±5 μm)	±0.1% F.S. (±10 μm)	±0.03% F.S. (±6 μm)	±0.075% F.S. (±15 μm)	±0.025% F.S. (±17.5 μm)	±0.07% F.S. (±49 μm)
		when used at 20 to 25 mm		when used at 40 to 50 mm		when used at 65 to 100 mm	
Linearity *2	Total area	±0.08% F.S. (±8 μm)	±0.125% F.S. (±12.5 μm)	±0.04% F.S. (±8 μm)	±0.1% F.S. (±20 μm)	±0.065% F.S. (±45.5 μm)	±0.085% F.S. (±59.5 μm)
		when used at 20 to 30 mm		when used at 40 to 60 mm		when used at 65 to 135 mm	
Resolution (Repeatability) *3	0.5 μm	0.6 μm	0.7 μm	0.8 μm	1.2 μm	1.3 μm	
Temperature characteristics *4	0.01% F.S./°C		0.01% F.S./°C		0.01% F.S./°C		
Indicators	2 indicators (identified by color) HIGH (orange)/PASS (green)/LOW (orange), Out of range (white), Error (red), SETTING mode (blue)						
Ambient illuminance	Illuminance of light-receiving surface, Incandescent lamp: 10,000 lx max.						
Ambient temperature range	Operating: -10 to 50°C, Storage: -15 to 70°C (with no icing or condensation)						
Ambient humidity range	Operating and storage: 35% to 85% RH each (with no condensation)						
Degree of protection	IP67 (IEC60529)						
Material	Case and cover: Polybutylene terephthalate, Optical window: Glass, Threaded portion: SUS304, Cable: PVC						
Weight (Main unit only)	Approx. 90 g (Cable length: 2 m), Approx. 45 g (Cable length: 0.2 m)						

Item	Specification				
	ZP-LS300L(C)	ZP-LS300S(C)	ZP-LS600L(C)	ZP-LS600S(C)	
Reference distance	300 mm		600 mm		
Measurement distance	150~450 mm		200~1000 mm		
Light source	Red semiconductor laser				
Wavelength	660 nm				
Laser class	ZP-LS□L, ZP-LS□S: Class 2 (JIS/IEC/EN/FDA/GB) ZP-LS□LC, ZP-LS□SC: Class 1 (JIS/IEC/EN/FDA/GB)				
Laser power	ZP-LS□L, ZP-LS□S: 1 mW max. ZP-LS□LC, ZP-LS□SC: 0.376 mW max.				
Spot diameter *1	Approx. 340 × 2,800 μm	Approx. 310 μm dia.	Approx. 670 × 5,800 μm	Approx. 600 μm dia.	
Linearity *2	Near side	±0.03% F.S. (±90 μm)	±0.04% F.S. (±120 μm)	±0.06% F.S. (±480 μm)	±0.075% F.S. (±600 μm)
		when used at 150 to 300 mm		when used at 200 to 600 mm	
Linearity *2	Total area	±0.1% F.S. (±300 μm)	0.125% F.S. (±375 μm)	±0.15% F.S. (±1,200 μm)	±0.2% F.S. (±1,600 μm)
		when used at 150 to 450 mm		when used at 150 to 450 mm	
Resolution (Repeatability) *3	4 μm		14 μm		
Temperature characteristics *4	0.01% F.S./°C		0.02% F.S./°C		
Indicators	2 indicators (identified by color) HIGH (orange)/PASS (green)/LOW (orange), Out of range (white), Error (red), SETTING mode (blue)				
Ambient illuminance	Illuminance of light-receiving surface, Incandescent lamp: 5,000 lx max.				
Ambient temperature range	Operating: -10 to 50°C, Storage: -15 to 70°C (with no icing or condensation)				
Ambient humidity range	Operating and storage: 35% to 85% RH each (with no condensation)				
Degree of protection	IP67 (IEC60529)				
Material	Case and cover: Polybutylene terephthalate, Optical window: Glass, Threaded portion: SUS304, Cable: PVC				
Weight (Main unit only)	Approx. 110 g (Cable length: 2 m), Approx. 70 g (Cable length: 0.2 m)				

*1. This is the value (actual value) at the standard distance, which is defined as 1/e² (13.5%) of the central light intensity.

*2. This shows the error of displacement output relative to the ideal line when OMRON's standard target (white diffuse object) is measured.

Linearity and measured values may vary depending on the target object. F.S. refers to the entire measuring range (70 mm for ZP-LS100L).

*3. This shows the width of the variation of measured values when OMRON's standard target (white diffuse object) is measured at a reference distance with a measurement cycle of 1 ms and an average rate of 128 times.

*4. This is the value (typical value) measured at the reference distance, with the Sensor Head and OMRON's standard object (white diffuse object) fixed with an aluminum jig between them.

For details, refer to ZP-L Series Catalog (No. Q362).

Amplifier Unit

Master unit ZP-L30□0

Item		Specification			
		ZP-L3000	ZP-L3010	ZP-L3050	ZP-L3060
Master/Slave unit		Master Unit			
I/O type		NPN		PNP	
Analog output *1	Current output	4 to 20 mA Maximum load resistance: 350 Ω	No analog output	4 to 20 mA Maximum load resistance: 350 Ω	No analog output
	Voltage output	±5 V, 1 to 5 V, 0 to 5 V Output impedance: 100 Ω		±5 V, 1 to 5 V, 0 to 5 V Output impedance: 100 Ω	
Control output *2		HIGH/PASS/LOW/ Error output Open collector output: 30 VDC, 50 mA max., Residual voltage: 2 V max. N.O./N.C. switchable			
External input		Zero reset, Laser OFF, Timing, Reset, BANK When ON: 0 V short-circuit or 1.2 V max. When OFF: Open (Leakage current: 0.1 mA max.)		When ON: Power supply voltage short-circuit or within -1.2 V of power supply voltage When OFF: Open (Leakage current: 0.1 mA max.)	
Measurement cycle		125 μs/250 μs/500 μs/1 ms/2 ms/4 ms/20 ms/50 ms/100 ms switchable			
Maximum number of connected units		16 (15 slave units can be connected per master unit)			
Display		OLED display Judgment indicators: HIGH (orange/red), PASS (green/red), LOW (orange/red) Status indicators: LASER (green), ZERO (green), ENABLE (green)			
Power supply voltage *3		10 to 30 VDC, including 10% ripple (p-p)			
Power consumption *4		2,300 mW max.	2,000 mW max.	2,300 mW max.	2,000 mW max.
Ambient temperature range		Operating: -10 to 50°C (standalone or multi-unit connection) Storage: -15 to 70°C (with no icing or condensation)			
Ambient humidity range		Operating and storage: 35% to 85% RH each (with no condensation)			
Degree of protection *5		IP40 (IEC60529)			
Material		Main unit case, operating section cover: Polycarbonate Cable: PVC			
Weight (Main unit only)		Approx. 160 g	Approx. 150 g	Approx. 160 g	Approx. 150 g

*1. Select ±5 V, 1 to 5 V, 0 to 5 V, or 4 to 20 mA to use this.

*2. When six or more Amplifier Units are added including the master unit, use a load current of 20 mA/ch or less.

*3. Use a Class 2 power supply to supply power to this product. When six or more Amplifier Units are added including the master unit, use a power supply voltage of 20 to 30 V, including 10% ripple (p-p).

*4. This includes the power consumption of the Sensor Head. It does not include the load current of each output.

*5. For slave units, this indicates the degree of protection when connected.

Slave unit ZP-L35□0

Item		Specification				
		ZP-L3500	ZP-L3510	ZP-L3550	ZP-L3560	ZP-L3590
Master/Slave unit		Slave Unit				
I/O type		NPN		PNP		No I/O
Analog output *1	Current output	4 to 20 mA Maximum load resistance: 350 Ω	No analog output	4 to 20 mA Maximum load resistance: 350 Ω	No analog output	
	Voltage output	±5 V, 1 to 5 V, 0 to 5 V Output impedance: 100 Ω		±5 V, 1 to 5 V, 0 to 5 V Output impedance: 100 Ω		
Control output *2		HIGH/PASS/LOW/ Error output Open collector output: 30 VDC, 50 mA max., Residual voltage: 2 V max. N.O./N.C. switchable				No control output
External input		Zero reset, Laser OFF, Timing, Reset, BANK When ON: 0 V short-circuit or 1.2 V max. When OFF: Open (Leakage current: 0.1 mA max.)		When ON: Power supply voltage short-circuit or within -1.2 V of power supply voltage When OFF: Open (Leakage current: 0.1 mA max.)		No external input
Measurement cycle		125 μs/250 μs/500 μs/1 ms/2 ms/4 ms/20 ms/50 ms/100 ms switchable				
Maximum number of connected units		16 (15 slave units can be connected per master unit)				
Display		OLED display Judgment indicators: HIGH (orange/red), PASS (green/red), LOW (orange/red) Status indicators: LASER (Green), ZERO (Green), ENABLE (Green)				
Power supply voltage *3		Supplied by master unit				
Power consumption *4		2,300 mW max.	2,000 mW max.	2,300 mW max.	2,000 mW max.	
Ambient temperature range		Operating: -10 to 50°C (standalone or multi-unit connection) *6 Storage: -15 to 70°C (with no icing or condensation)				
Ambient humidity range		Operating and storage: 35% to 85% RH each (with no condensation)				
Degree of protection *5		IP40 (IEC60529)				
Material		Main unit case, operating section cover: Polycarbonate Cable: PVC				Main unit case, operating section cover: Polycarbonate
Weight (Main unit only)		Approx. 150 g	Approx. 140 g	Approx. 150 g	Approx. 140 g	Approx. 70 g

*1. Select ±5 V, 1 to 5 V, 0 to 5 V, or 4 to 20 mA to use this.

*2. When six or more Amplifier Units are added including the master unit, use a load current of 20 mA/ch or less.

*3. Use a Class 2 power supply to supply power to this product. When six or more Amplifier Units are added including the master unit, use a power supply voltage of 20 to 30 V, including 10% ripple (p-p).

*4. This includes the power consumption of the Sensor Head. It does not include the load current of each output.

*5. This indicates the degree of protection when connected to a master unit.

*6. If the total number of connected amplifier units, including the master unit, is three or more and includes a ZP-L3500/-L3550, use the unit in an ambient temperature range (during operation) of -10 to 45°C.

Dimensions

Sensors

Sensor Head

- ZP-LS025□
- ZP-LS050□
- ZP-LS100□

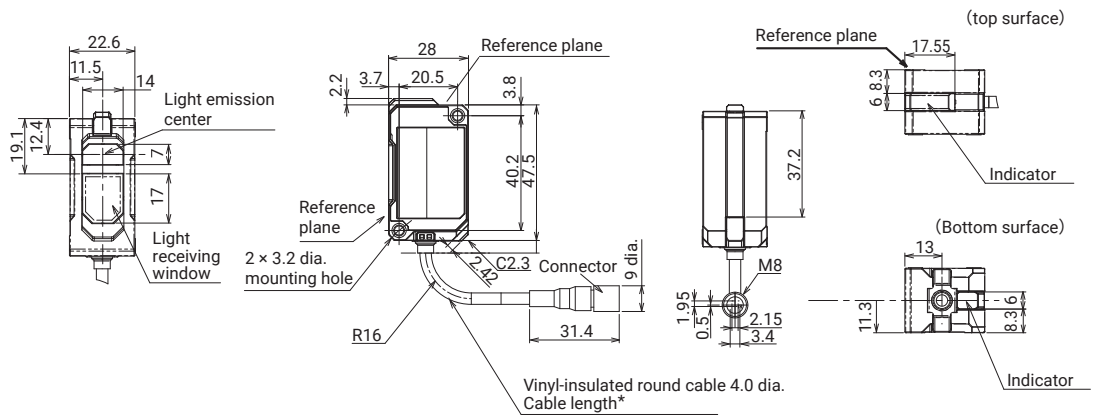

* Length specification	Standard length (mm)
0.2 M	(260)
2 M	(2000)

- ZP-LS300□
- ZP-LS600□

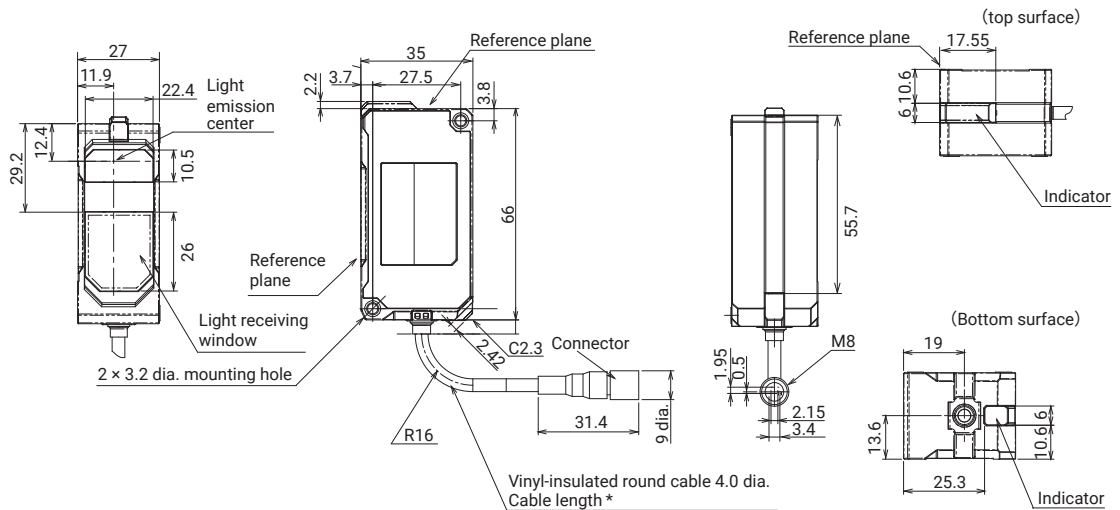

* Length specification	Standard length (mm)
0.2 M	(260)
2 M	(2000)

Amplifier unit

Master unit

- ZP-L30□0

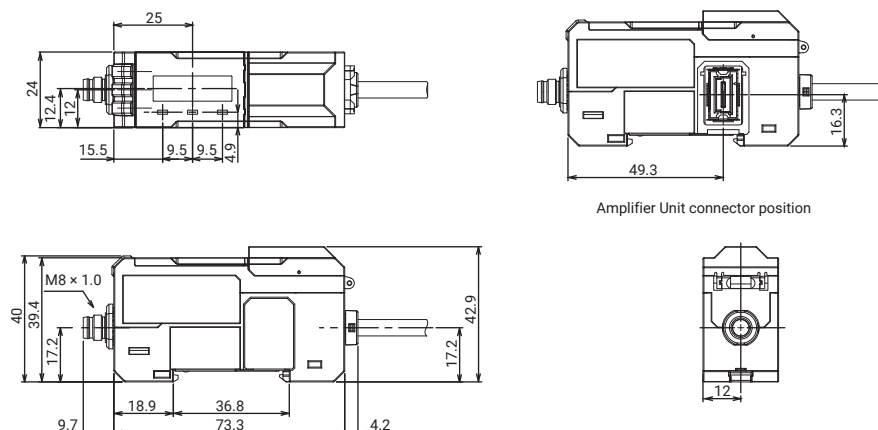

Slave unit

- ZP-L3500
- ZP-L3510
- ZP-L3550
- ZP-L3560

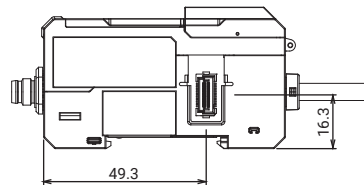
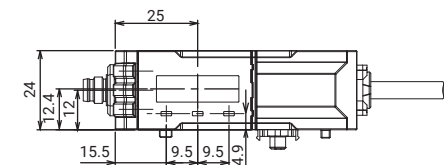

Amplifier Unit connector position

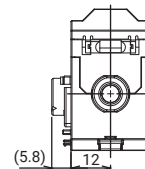
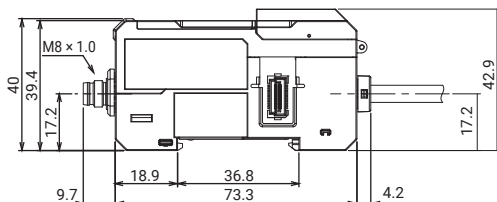

ZP-L3590

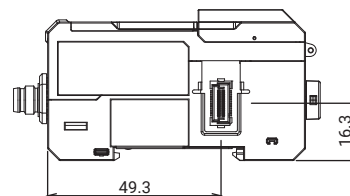
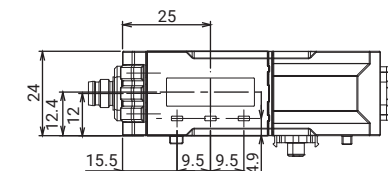

Unit coupling connector position

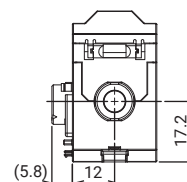
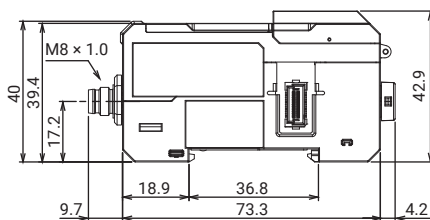

Communication Unit

ZP-EIP

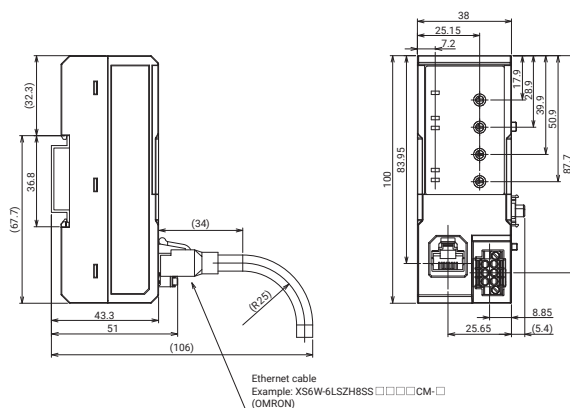

ZP-RSA

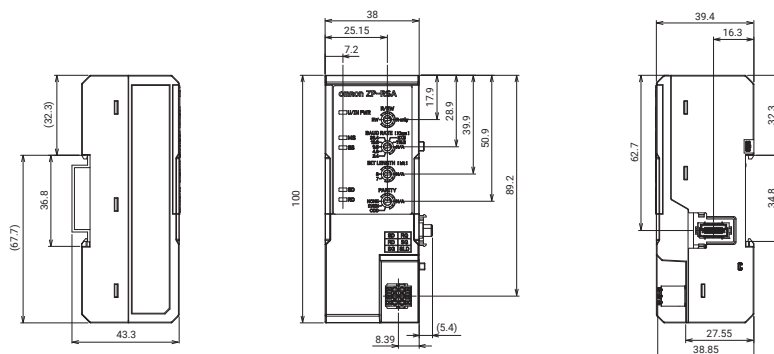

The equivalent products listed in this document refer to items with comparable basic performance and do not guarantee complete compatibility when replacing. The referenced information is based on our estimation using official data from each manufacturer at the time of acquisition, and we make no warranty regarding the accuracy or completeness of such information. When selecting and using equivalent products, please ensure you review the latest catalogs and instruction manuals, evaluate suitability for your intended application, and make decisions regarding use and safety measures at your own responsibility.

Terms and Conditions Agreement

Read and understand this catalog.

Please read and understand this catalog before purchasing the products. Please consult your OMRON representative if you have any questions or comments.

Warranties.

- (a) Exclusive Warranty. Omron's exclusive warranty is that the Products will be free from defects in materials and workmanship for a period of twelve months from the date of sale by Omron (or such other period expressed in writing by Omron). Omron disclaims all other warranties, express or implied.
- (b) Limitations. OMRON MAKES NO WARRANTY OR REPRESENTATION, EXPRESS OR IMPLIED, ABOUT NON-INFRINGEMENT, MERCHANTABILITY OR FITNESS FOR A PARTICULAR PURPOSE OF THE PRODUCTS. BUYER ACKNOWLEDGES THAT IT ALONE HAS DETERMINED THAT THE PRODUCTS WILL SUITABLY MEET THE REQUIREMENTS OF THEIR INTENDED USE.

Omron further disclaims all warranties and responsibility of any type for claims or expenses based on infringement by the Products or otherwise of any intellectual property right. (c) Buyer Remedy. Omron's sole obligation hereunder shall be, at Omron's election, to (i) replace (in the form originally shipped with Buyer responsible for labor charges for removal or replacement thereof) the non-complying Product, (ii) repair the non-complying Product, or (iii) repay or credit Buyer an amount equal to the purchase price of the non-complying Product; provided that in no event shall Omron be responsible for warranty, repair, indemnity or any other claims or expenses regarding the Products unless Omron's analysis confirms that the Products were properly handled, stored, installed and maintained and not subject to contamination, abuse, misuse or inappropriate modification. Return of any Products by Buyer must be approved in writing by Omron before shipment. Omron Companies shall not be liable for the suitability or unsuitability or the results from the use of Products in combination with any electrical or electronic components, circuits, system assemblies or any other materials or substances or environments. Any advice, recommendations or information given orally or in writing, are not to be construed as an amendment or addition to the above warranty.

See <http://www.omron.com/global/> or contact your Omron representative for published information.

Limitation on Liability; Etc.

OMRON COMPANIES SHALL NOT BE LIABLE FOR SPECIAL, INDIRECT, INCIDENTAL, OR CONSEQUENTIAL DAMAGES, LOSS OF PROFITS OR PRODUCTION OR COMMERCIAL LOSS IN ANY WAY CONNECTED WITH THE PRODUCTS, WHETHER SUCH CLAIM IS BASED IN CONTRACT, WARRANTY, NEGLIGENCE OR STRICT LIABILITY.

Further, in no event shall liability of Omron Companies exceed the individual price of the Product on which liability is asserted.

Suitability of Use.

Omron Companies shall not be responsible for conformity with any standards, codes or regulations which apply to the combination of the Product in the Buyer's application or use of the Product. At Buyer's request, Omron will provide applicable third party certification documents identifying ratings and limitations of use which apply to the Product. This information by itself is not sufficient for a complete determination of the suitability of the Product in combination with the end product, machine, system, or other application or use. Buyer shall be solely responsible for determining appropriateness of the particular Product with respect to Buyer's application, product or system. Buyer shall take application responsibility in all cases.

NEVER USE THE PRODUCT FOR AN APPLICATION INVOLVING SERIOUS RISK TO LIFE OR PROPERTY OR IN LARGE QUANTITIES WITHOUT ENSURING THAT THE SYSTEM AS A WHOLE HAS BEEN DESIGNED TO ADDRESS THE RISKS, AND THAT THE OMRON PRODUCT(S) IS PROPERLY RATED AND INSTALLED FOR THE INTENDED USE WITHIN THE OVERALL EQUIPMENT OR SYSTEM.

Programmable Products.

Omron Companies shall not be responsible for the user's programming of a programmable Product, or any consequence thereof.

Performance Data.

Data presented in Omron Company websites, catalogs and other materials is provided as a guide for the user in determining suitability and does not constitute a warranty. It may represent the result of Omron's test conditions, and the user must correlate it to actual application requirements. Actual performance is subject to the Omron's Warranty and Limitations of Liability.

Change in Specifications.

Product specifications and accessories may be changed at any time based on improvements and other reasons. It is our practice to change part numbers when published ratings or features are changed, or when significant construction changes are made. However, some specifications of the Product may be changed without any notice. When in doubt, special part numbers may be assigned to fix or establish key specifications for your application. Please consult with your Omron's representative at any time to confirm actual specifications of purchased Product.

Errors and Omissions.

Information presented by Omron Companies has been checked and is believed to be accurate; however, no responsibility is assumed for clerical, typographical or proofreading errors or omissions.

Related Products

Compact Laser Photoelectric Sensor with Built-in Amplifier **E3Z-LT/LR/LL**

Compact laser photoelectric sensor featuring Class 1 laser and the trusted quality and reliability of the E3Z series.

- Combines the superior directionality and visibility unique to laser sensor
- Through-beam models sensing distance: Industry's top-class *1 60 m
- Same 25.4 mm mounting hole pitch as standard built-in amplifier photoelectric sensors

*1. Based on OMRON investigation in November 2025.



- EtherNet/IP™ is a trademark of ODVA.
- Ecolab and its logo are registered trademarks of Ecolab USA Inc.
- QR code is the registered trademark of DENSO WAVE.
- Smartclick is a trademark or registered trademark of OMRON Corporation in Japan and other countries.
- Microsoft product screen shot(s) reprinted with permission from Microsoft Corporation.
- Other company names and product names in this document are the trademarks or registered trademarks of their respective companies.
- The product photographs and figures that are used in this catalog may vary somewhat from the actual products.

Note: Do not use this document to operate the Unit.

OMRON Corporation Industrial Automation Company

Kyoto, JAPAN

Contact : www.ia.omron.com

Regional Headquarters

OMRON EUROPE B.V.

Wegalaan 67-69, 2132 JD Hoofddorp
The Netherlands
Tel: (31) 2356-81-300 Fax: (31) 2356-81-388

OMRON ASIA PACIFIC PTE. LTD.

438B Alexandra Road, #08-01/02 Alexandra
Technopark, Singapore 119968
Tel: (65) 6835-3011 Fax: (65) 6835-3011

OMRON ELECTRONICS LLC

2895 Greenspoint Parkway, Suite 200
Hoffman Estates, IL 60169 U.S.A.
Tel: (1) 847-843-7900 Fax: (1) 847-843-7787

OMRON (CHINA) CO., LTD.

Room 2211, Bank of China Tower,
200 Yin Cheng Zhong Road,
PuDong New Area, Shanghai, 200120, China
Tel: (86) 21-6023-0333 Fax: (86) 21-5037-2388

Authorized Distributor:

©OMRON Corporation 2025-2026 All Rights Reserved.
In the interest of product improvement,
specifications are subject to change without notice.

CSM_2_1

Cat. No. E628-E1-02 0426 (1225)