

Compact Photoelectric Sensor with Built-in Amplifier

E3Z-□-UL

CSM_E3Z_-UL_DS_E_2_1

The lineup has been expanded to standard photoelectric sensor E3Z series with UL certified products

- Long sensing distance of 30 m for Through-beam Models, 4 m for Retro-reflective Models, and 1 m for Diffuse-reflective Models.
- Mechanical axis and optical axis offset of less than $\pm 2.5^\circ$ simplifies optical axis adjustment.
- High stability with unique algorithm that prevents interference of external light.
- Models are available with Laser type and IO-Link type.
- UL certification (UL60947-5-2) and CSA certification (CSA-C22.2 No.60947-5-2)



Be sure to read *Safety Precautions* on page 28.

For the most recent information on models that have been certified for safety standards, refer to your OMRON website.

Ordering Information

Standard Model / Sensors [Refer to *Dimensions* on page 30 to 34.]

Red light Infrared light

Sensing method	Appearance	Connection method	Sensing distance	Model	
				NPN output	PNP output
Through-beam (Emitter + Receiver) *1		Pre-wired (2 m)		E3Z-T61-UL 2M *4 Emitter E3Z-T61-L-UL 2M Receiver E3Z-T61-D-UL 2M	E3Z-T81-UL 2M *4 Emitter E3Z-T81-L-UL 2M Receiver E3Z-T81-D-UL 2M
		M8 (4-pin) Connector		E3Z-T66-UL Emitter E3Z-T66-L-UL Receiver E3Z-T66-D-UL	E3Z-T86-UL Emitter E3Z-T86-L-UL Receiver E3Z-T86-D-UL
		Pre-wired (2 m)		E3Z-T61A-UL 2M *4 Emitter E3Z-T61A-L-UL 2M Receiver E3Z-T61A-D-UL 2M	E3Z-T81A-UL 2M *4 Emitter E3Z-T81A-L-UL 2M Receiver E3Z-T81A-D-UL 2M
		M8 (4-pin) Connector		E3Z-T66A-UL Emitter E3Z-T66A-L-UL Receiver E3Z-T66A-D-UL	E3Z-T86A-UL Emitter E3Z-T86A-L-UL Receiver E3Z-T86A-D-UL
		Pre-wired (2 m)		E3Z-T62-UL 2M Emitter E3Z-T62-L-UL 2M Receiver E3Z-T62-D-UL 2M	E3Z-T82-UL 2M *4 Emitter E3Z-T82-L-UL 2M Receiver E3Z-T82-D-UL 2M
		M8 (4-pin) Connector		E3Z-T67-UL Emitter E3Z-T67-L-UL Receiver E3Z-T67-D-UL	E3Z-T87-UL Emitter E3Z-T87-L-UL Receiver E3Z-T87-D-UL
Retro-reflective with MSR function		Pre-wired (2 m)		E3Z-R61-UL 2M *4	E3Z-R81-UL 2M *4
	M8 (4-pin) Connector			E3Z-R66-UL	E3Z-R86-UL
Diffuse-reflective		Pre-wired (2 m)		E3Z-D61-UL 2M	E3Z-D81-UL 2M *4
		M8 (4-pin) Connector			E3Z-D66-UL
		Pre-wired (2 m)		E3Z-D62-UL 2M *4	E3Z-D82-UL 2M *4
		M8 (4-pin) Connector			E3Z-D67-UL
		Pre-wired (2 m)		E3Z-L61-UL 2M *4	E3Z-L81-UL 2M *4
		M8 (4-pin) Connector			E3Z-L66-UL

Sensing method	Appearance	Connection method	Sensing distance	Model	
				NPN output	PNP output
Distance-settable		Pre-wired (2 m)	20 to 40 mm (BGS min setting) 20 to 200 mm (BGS max setting)	E3Z-LS61-UL 2M	E3Z-LS81-UL 2M
		M8 (4-pin) Connector	40 min. Incident threshold (FGS min setting) 200 min. Incident threshold (FGS max setting)	E3Z-LS66-UL	E3Z-LS86-UL
		Pre-wired (2 m)	2 to 20 mm (BGS min setting)	E3Z-LS63-UL 2M	E3Z-LS83-UL 2M
		M8 (4-pin) Connector	2 to 80 mm (BGS max setting)	E3Z-LS68-UL	E3Z-LS88-UL
Limited-reflective for transparent glasses		Pre-wired (2 m)	30±20 mm	E3Z-L63-UL 2M	E3Z-L83-UL 2M
		M8 (4-pin) Connector		E3Z-L68-UL	E3Z-L88-UL
Retro-reflective without MSR function for clear, plastic bottles		Pre-wired (2 m)	500 mm (80 mm) ^{*3}	E3Z-B61-UL 2M	E3Z-B81-UL 2M
		M8 (4-pin) Connector		E3Z-B66-UL	E3Z-B86-UL
		Pre-wired (2 m)	2 m (500 mm) ^{*3}	E3Z-B62-UL 2M	E3Z-B82-UL 2M
		M8 (4-pin) Connector		E3Z-B67-UL	E3Z-B87-UL

- *1. Through-beam Sensors are normally sold in sets that include both the Emitter and Receiver.
- *2. The Reflector is sold separately. Select the Reflector model most suited to the application.
- *3. The sensing distance specified is possible when the E39-R1S is used. Values in parentheses indicate the minimum required distance between the Sensor and Reflector.
- *4. M12 Pre-wired Smartclick Connector Models are also available. When ordering, add "-M1TJ 0.3M" between the model number (e.g., E3Z-T61-M1TJ-UL 0.3M). The cable is 0.3 m long. The applicable Sensor I/O Connector is the XS5 Series. For details, refer to the XS5 information available on the OMRON website.







Laser Model / Sensors (Refer to Dimensions on page 30 to 34.)

Red light

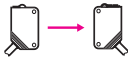
Sensing method	Appearance	Connection method	Response time	Sensing distance	Model	
					NPN output	PNP output
Through-beam (Emitter + Receiver) ^{*1}		Pre-wired (2 m)	1 ms	60 m	E3Z-LT61-UL 2M ^{*4} Emitter E3Z-LT61-L-UL 2M Receiver E3Z-LT61-D-UL 2M	E3Z-LT81-UL 2M ^{*4} Emitter E3Z-LT81-L-UL 2M Receiver E3Z-LT81-D-UL 2M
		M8 (4-pin) Connector			E3Z-LT66-UL Emitter E3Z-LT66-L-UL Receiver E3Z-LT66-D-UL	E3Z-LT86-UL Emitter E3Z-LT86-L-UL Receiver E3Z-LT86-D-UL
Retro-reflective with MSR function		Pre-wired (2 m)	1 ms	15 m (300 mm) ^{*3} (Using E39-R1)	E3Z-LR61-UL 2M	E3Z-LR81-UL 2M
		M8 (4-pin) Connector		7 m (200 mm) (Using E39-R12)		
M8 (4-pin) Connector	7 m (200 mm) (Using E39-R6)			E3Z-LR66-UL	E3Z-LR86-UL	
	Distance-settable (BGS Models)			Pre-wired (2 m)	0.5 ms	20 to 40 mm (Min. distance set)
M8 (4-pin) Connector			20 to 300 mm (Max. distance set)	E3Z-LL66-UL		E3Z-LL86-UL
Pre-wired (2 m)			25 to 40 mm (Min. distance set)	E3Z-LL63-UL 2M	E3Z-LL83-UL 2M	
M8 (4-pin) Connector			25 to 300 mm (Max. distance set)	E3Z-LL68-UL	E3Z-LL88-UL	

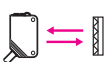
- *1. Through-beam Sensors are normally sold in sets that include both the Emitter and Receiver.
- *2. The Reflector is sold separately. Select the Reflector model most suited to the application.
- *3. Values in parentheses indicate the minimum required distance between the Sensor and Reflector.
- *4. M12 Pre-wired Smartclick Connector Models are also available. When ordering, add "-M1TJ" between the model number. (Example: E3Z-LT61-M1TJ-UL 0.3M) The cable is 0.3 m long. The applicable Sensor I/O Connector is the XS5 Series. For details, refer to the XS5 information available on the OMRON website.

IO-Link Model / Sensors [Refer to *Dimensions* on page 30 to 34.]
 Red light
  Infrared light

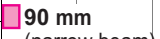
Sensing method	Appearance	Connection method	Sensing distance		IO-Link baud rate	Model	
						PNP	
Through-beam (Emitter + Receiver) *1		Pre-wired (2 m)		15 m	COM2 (38.4 kbps)	E3Z-T81-IL2-UL 2M	
		M8 (4-pin) Connector				E3Z-T86-IL2-UL	
		Pre-wired (2 m)				E3Z-T81-IL3-UL 2M	
		M8 (4-pin) Connector				E3Z-T86-IL3-UL	
Retro-reflective with MSR function		Pre-wired (2 m)		4 m (100 mm) *3	COM2 (38.4 kbps)	E3Z-R81-IL2-UL 2M	
		M8 (4-pin) Connector				E3Z-R86-IL2-UL	
		Pre-wired (2 m)				E3Z-R81-IL3-UL 2M	
		M8 (4-pin) Connector				E3Z-R86-IL3-UL	
Diffuse-reflective		Pre-wired (2 m)		1 m	COM2 (38.4 kbps)	E3Z-D82-IL2-UL 2M	
		M8 (4-pin) Connector				E3Z-D87-IL2-UL	
		Pre-wired (2 m)				E3Z-D82-IL3-UL 2M	
		M8 (4-pin) Connector				E3Z-D87-IL3-UL	
		Pre-wired (2 m)		90 mm (narrow beam)	COM2 (38.4 kbps)	E3Z-L81-IL2-UL 2M	
		M8 (4-pin) Connector				E3Z-L86-IL2-UL	
		Pre-wired (2 m)				E3Z-L81-IL3-UL 2M	
		M8 (4-pin) Connector				E3Z-L86-IL3-UL	

Note: Please contact your OMRON sales representative regarding the IO-Link setup file (IODD file).

*1. Through-beam Sensors are sold in sets that include both the Emitter and Receiver.

*2. The Reflector is sold separately. Select the Reflector model most suited to the application.

*3. The sensing distance specified is possible when the E39-R1S is used. Values in parentheses indicate the minimum required distance between the Sensor and Reflector.

Accessories (Order Separately)

Slit (A Slit is not provided with Through-beam Sensors) Order a Slit separately if required. [Refer to *Dimensions* on page 35.]

Slit width	Sensing distance			Minimum detectable object (Reference value)		Model	Contents
	E3Z-T□□ (sensing distance of 15 m)	E3Z-T□□A (sensing distance of 10 m)	E3Z-LT (sensing distance of 60 m)	E3Z-T□□(A)	E3Z-LT		
0.5-mm dia.	50 mm	35 mm	3 m	0.2-mm dia.	0.1-mm dia.	E39-S65A	One set (contains Slits for both the Emitter and Receiver)
1-mm dia.	200 mm	150 mm	---	0.4-mm dia.	---	E39-S65B	
2-mm dia.	800 mm	550 mm	---	0.7-mm dia.	---	E39-S65C	
0.5 × 10 mm	1 m	700 mm	---	0.2-mm dia.	---	E39-S65D	
1 × 10 mm	2.2 m	1.5 m	---	0.5-mm dia.	---	E39-S65E	
2 × 10 mm	5 m	3.5 m	---	0.8-mm dia.	---	E39-S65F	

Reflectors (Reflector required for Retroreflective Sensors)

A Reflector is not provided with the Sensor. Be sure to order a Reflector separately. [Refer to *Dimensions* on E39-L/E39-S/E39-R]

Name	Sensing distance *						Model	Quantity
	E3Z-R		E3Z-B□1/-B□6	E3Z-B□2/-B□7	E3Z-LT			
	Rated value	Reference value	Rated value	Rated value	Rated value	Reference value		
Reflector	3 m (100 mm)	---	---	---	---	15 m (300 mm)	E39-R1	1
	4 m (100 mm)	---	500 mm (80 mm)	2 m (500 mm)	---	---	E39-R1S	1
	---	5 m (100 mm)	---	---	---	---	E39-R2	1
	---	---	---	---	---	7 m (200 mm)	E39-R6	1
	---	2.5 m (100 mm)	---	---	---	---	E39-R9	1
	---	3.5 m (100 mm)	---	---	---	---	E39-R10	1
Fog Preventive Coating	---	3 m (100 mm)	500 mm (80 mm)	2 m (500 mm)	---	---	E39-R1K	1
Small Reflector	---	1.5 m (50 mm)	---	---	---	---	E39-R3	1
Tape Reflector	---	700 mm (150 mm)	---	---	---	---	E39-RS1	1
	---	1.1 m (150 mm)	---	---	---	---	E39-RS2	1
	---	1.4 m (150 mm)	---	---	---	---	E39-RS3	1

Note: 1. If you use the Reflector at any distance other than the rated distance, make sure that the stability indicator lights properly when you install the Sensor.

Note: 2. The MSR function of the E3Z-R□ and E3Z-LT is enabled.

Note: 3. For details, refer to *Reflectors* on the E39-L/E39-S/E39-R information available on the OMRON website.

* Values in parentheses indicates the minimum required distance between the Sensor and Reflector.

Mutual Interference Protection Filter

A Filter is not provided with the Sensor. Order a Filter separately if required.









Sensing distance	Appearance/Dimensions	Model	Quantity	Remarks
3 m		E39-E11	Two sets each for the Emitter and Receiver (total of four pieces)	Can be used with the E3Z-T□□A Through-beam models.
2.5 m		E39-E12	Two sets each for the Emitter and Receiver (total of four pieces)	Can be used with the E3Z-T□□□ Through beam models. E39-E12 is designed for permanent bonding to sensors. Do not remove it from the sensor and reuse it.

Note: 1. The arrow indicates the direction of polarized light. Mutual interference can be prevented by altering the direction of polarized light from or to adjacent Emitters 0.2 and Receivers.

Note: 2. The polarization directions of the Filters are offset by 90° to prevent interference. When you install the Emitter and Receiver, install them at the same angle to maintain this offset.

Note: 3. Do not use the slit and mutual interference protection filter at the same time.

Mounting Brackets A Mounting Bracket is not enclosed with the Sensor. Order a Mounting Bracket separately if required.

Appearance	Model (material)	Quantity	Remarks	Appearance	Model (material)	Quantity	Remarks
	E39-L153 (SUS304) *1	1	Mounting Brackets		E39-L98 (SUS304) *2	1	Metal Protective Cover Bracket
	E39-L104 (SUS304) *1	1			E39-L150 (SUS304)	1	(Sensor adjuster)
	E39-L43 (SUS304) *2	1	Horizontal Mounting Brackets		E39-L151 (SUS304)	1	Easily mounted to the aluminum frame rails of conveyors and easily adjusted.
	E39-L142 (SUS304) *2	1	Horizontal Protective Cover Bracket				For left to right adjustment
	E39-L44 (SUS304)	1	Rear Mounting Bracket		E39-L144 (SUS304) *2	1	Compact Protective Cover Bracket (For E3Z only)

Note: 1. When using Through-beam models, order one bracket for the Receiver and one for the Emitter.





Note: 2. For details, refer to *Mounting Brackets* on the *E39-L/E39-S/E39-R* information available on the OMRON website.

*1. Cannot be used for Standard Connector models with mounting surface on the bottom. In that case, use Pre-wired Connector models.

*2. Cannot be used for Standard Connector models.

Flexible Mounting Brackets / Air Blow Unit These are not enclosed with the Sensor. Order separately if required.

[Refer to *Dimensions* on page 36]

Appearance	Model (material)
Flexible Mounting Bracket 	E39-L261 *1 (SUS304)
Post 50 mm 	E39-L262
Post 100 mm 	E39-L263
Air Blow Unit 	E39-E16 *2

Note: 1. When using Through-beam models, order one bracket for the Receiver and one for the Emitter.

*1. The Flexible Mounting Bracket is not provided with a Post (E39-L262/E39-L263). It must be ordered separately.

*2. The tube for air is not included.



Accessories (Sold Separately)

Sensor I/O Connectors (Sockets on One Cable End)

(Models for Connectors / Pre-wired Connectors)

A Sensor I/O Connector is not provided with the Sensor. It must be ordered separately as required.

Round Water-resistant Connectors XS3F-M8 series



Appearance	Cable specification	Cable diameter (mm)	Cable connection direction	Cable length (m)	Sensor I/O Connector model number
M8 Connector Straight type 	PVC robot cable	4 dia.	Straight	2	XS3F-M421-402-R
				5	XS3F-M421-405-R
Right-angle type 			Right-angle	2	XS3F-M422-402-R
				5	XS3F-M422-405-R
	PUR cable (low-temperature use)	4 dia.	Straight	2	XS3F-M421-402-L
				5	XS3F-M421-405-L
			Right-angle	2	XS3F-M422-402-L
				5	XS3F-M422-405-L

Note: 1. The XS3W (Socket and Plug on Cable Ends), Cable length 1m and 10m is also available. Refer to *XS3 Series Datasheet* (Cat. No. G147).

Note: 2. The connectors will not rotate after they are connected.

Note: 3. The cable is fixed at an angle of 180° from the sensor emitter/receiver surface.

Round Water-resistant Connectors XS5 series

Appearance	Cable specification	Cable diameter (mm)	Cable connection direction	Cable length (m)	Sensor I/O Connector model number
M12 Smartclick Connector Straight type 	PVC robot cable	6 dia.	Straight	2	XS5F-D421-D80-F
				5	XS5F-D421-G80-F
Right-angle type 			Right-angle	2	XS5F-D422-D80-F
				5	XS5F-D422-G80-F

Note: 1. The XS5W (Socket and Plug on Cable Ends) is also available. Refer to *XS5* on your OMRON website for details.

Note: 2. The connectors will not rotate after they are connected.

Note: 3. The cable is fixed at an angle of 180° from the sensor emitter/receiver surface.

Ratings and Specifications

Standard Model

Item	Sensing method		Through-beam			Retro-reflective with MSR function	Diffuse-reflective		(Narrow-beam Models)
	Model		E3Z-T61-UL	E3Z-T62-UL	E3Z-T61A-UL	E3Z-R61-UL	E3Z-D61-UL	E3Z-D62-UL	E3Z-L61-UL
	NPN output	Pre-wired	E3Z-T66-UL	E3Z-T67-UL	E3Z-T66A-UL	E3Z-R66-UL	E3Z-D66-UL	E3Z-D67-UL	E3Z-L66-UL
		M8 Connector	E3Z-T81-UL	E3Z-T82-UL	E3Z-T81A-UL	E3Z-R81-UL	E3Z-D81-UL	E3Z-D82-UL	E3Z-L81-UL
	PNP output	Pre-wired	E3Z-T86-UL	E3Z-T87-UL	E3Z-T86A-UL	E3Z-R86-UL	E3Z-D86-UL	E3Z-D87-UL	E3Z-L86-UL
		M8 Connector							
Sensing distance			15 m	30 m	10 m	4 m (100 mm) *1 (when using E39-R1S) 3 m (100 mm) *1 (when using E39-R1)	100 mm (white paper: 100 × 100 mm)	1 m (white paper: 300 × 300 mm)	90 + 30 mm (white paper, 100 x 100 mm)
Spot diameter (reference value)			---						(2.5 dia. and sensing distance of 90 mm)
Standard sensing object			Opaque: 12-mm dia. min.			Opaque: 75-mm dia. min.		---	
Minimum detectable object (reference value)			---						0.1 mm (copper wire)
Differential travel (representative example)			---			20% max. of setting distance		Refer to <i>Engineering data</i> on page 12.	
Directional angle			Both emitter and receiver: 3 to 15°			2 to 10°		---	
Light source (wavelength)			Infrared LED (870 nm)		Red LED (660 nm)	Red LED (660 nm)	Infrared LED (870 nm)		Red LED (650 nm)
Power supply voltage			12 to 24 VDC ±10%, ripple (p-p): 10% max. Class 2						
Current consumption			35 mA max. (Emitter: 15 mA max., Receiver: 20 mA max.)			30 mA max.			
Control output			Load power supply voltage: 26.4 VDC max., Load current: 100 mA max. (Residual voltage: Load current of less than 10 mA: 1 V max. Load current of 10 to 100 mA: 2 V max.) Open collector output (NPN/PNP depending on model) Light-ON/Dark-ON selectable						
Indicator			Operation indicator (orange) Stability indicator (green) Through-beam Emitter has power indicator (orange) only.						
Protection circuits			Reversed power supply polarity protection, Output short-circuit protection, and Reversed output polarity protection			Reversed power supply polarity protection, Output short-circuit protection, Mutual interference prevention, and Reversed output polarity protection			
Response time			Operate or reset: 1 ms max.	Operate or reset: 2 ms max.	Operate or reset: 1 ms max.				
Sensitivity adjustment			One-turn adjuster						
Ambient illumination (Receiver side)			Incandescent lamp: 3,000 lx max. Sunlight: 10,000 lx max.						
Ambient temperature range			Operating: -25 to 55°C, Some connector models: -40°C to 55°C *2 (with no icing or condensation) Storage: -40 to 70°C (with no icing or condensation)						
Ambient humidity range			Operating: 35% to 85%, Storage: 35% to 95% (with no condensation)						
Insulation resistance			20 MΩ min. at 500 VDC						
Dielectric strength			1,000 VAC, 50/60 Hz for 1 min						
Vibration resistance			Destruction: 10 to 55 Hz, 1.5 mm double amplitude for 2 hours each in X, Y, and Z directions						
Shock resistance			Destruction: 500 m/s ² 3 times each in X, Y, and Z directions						
Degree of protection			IP67 (IEC 60529)						
Connection method			Pre-wired (standard cable length: 2 m) / M8 (4-pin) Connector						
Weight (packedstate)	Pre-wired cable (2 m)		Approx. 120 g			Approx. 65 g			
	M8 Connector		Approx. 30 g			Approx. 20 g			
Material	Case		PBT (polybutylene terephthalate)						
	Display		Polycarbonate (PC)						
	Lens		Modified polyarylate			Methacrylic resin	Modified polyarylate		

Note: 1. Altitude: Up to 2000 m, Pollution degree: 3, Enclosure type: Type1.

*1. Values in parentheses indicate the minimum required distances between the Sensors and Reflectors.

*2. The ambient temperature range during operation for connector models depends on the model.

For the E3Z-T66/T86/R66/R86, the range is -40°C to 55°C. E3Z-D66/D86/D67/D87, the range is -30°C to 55°C. Other connector models, the range is -25°C to -55°C.

The sensing distance for Retro-reflective Models (E3Z-R66/R86) between -40°C to -25°C, however, will be as follows (not the values in the table). E39-R1S: 3 m (100 mm) *1, With E39-R1: 2 m (100 mm) *1.

Also, use the XS3F-M42□-4□□-L Sensor I/O Connector (PUR cable) for applications between -25°C to -40°C.

Sensing method		Distance-settable			
		Pre-wired	M8 Connector	Pre-wired	M8 Connector
Item	Model	E3Z-LS61-UL	E3Z-LS66-UL	E3Z-LS63-UL	E3Z-LS68-UL
	NPN output	E3Z-LS81-UL	E3Z-LS86-UL	E3Z-LS83-UL	E3Z-LS88-UL
Sensing distance	BGS	White or black paper (100 × 100 mm): 20 mm to set distance		2 mm to set distance (80 mm max.)	
	FGS	White paper (100 × 100 mm): Set distance to 200 mm min. Black paper (100 × 100 mm): Set distance to 160 mm min.		-----	
Setting range		White paper (100 × 100 mm): 40 to 200 mm Black paper (100 × 100 mm): 40 to 160 mm		White paper (25 × 25 mm): 20 to 80 mm	
Differential travel		10% of set distance max. (Refer to <i>Differential Travel vs. Sensing Distance</i> on page 15.)		2% of set distance max.	
Reflectivity characteristic (black/white error)		10% of set distance max.		5% of set distance max.	
Light source (wavelength)		Red LED (670 nm)		Red LED (650 nm)	
Power supply voltage		12 to 24 VDC ±10%, ripple (p-p): 10% max. Class 2			
Current consumption		30 mA max.			
Control output		Load power supply voltage: 26.4 VDC max., Load current: 100 mA max. (residual voltage 1 V max.), Open collector output (NPN or PNP depending on model) Light-ON/Dark-ON switch selectable			
BGS/FGS selection		BGS: Open or connected to GND FGS: Connected to Vcc		BGS: Open or connected to GND	
Protection circuits		Reversed power supply polarity protection, Output short-circuit protection, Mutual interference prevention			
Response time		Operate or reset: 1 ms max.			
Distance setting		5-turn endless adjuster			
Ambient illumination (Receiver side)		Incandescent lamp: 3,000 lx max.; Sunlight: 10,000 lx max.			
Ambient temperature range		Operating: -25 to 55°C, Storage: -40 to 70°C (with no icing or condensation)			
Ambient humidity range		Operating: 35% to 85%, Storage: 35% to 95% (with no condensation)			
Insulation resistance		20 MΩ min. at 500 VDC			
Dielectric strength		1,000 VAC at 50/60 Hz for 1 minute			
Vibration resistance		Destruction: 10 to 55 Hz, 1.5-mm double amplitude for 2 hours each in X, Y, and Z directions			
Shock resistance		Destruction: 500 m/s ² for 3 times each in X, Y, and Z directions			
Degree of protection		IP67 (IEC 60529)			
Connection method		Pre-wired (standard cable length: 2 m) / M8 (4-pin) Connector			
Indicators		Operation indicator (orange), Stability indicator (green)			
Weight (packed state)		Pre-wired cable (2 m): Approx. 65 g	Approx. 20 g	Pre-wired cable (2 m): Approx. 65 g	Approx. 20 g
Material	Case	PBT (polybutylene terephthalate)			
	Display	Polycarbonate (PC)			
	Lens	Modified polyarylate resin			
Accessories		Instruction manual (Mounting Brackets must be ordered separately.)			

Note: 1. Altitude: Up to 2000 m, Pollution degree: 3, Enclosure type: Type1.

Sensing method		Transparent glass Limited-reflective (for transparent object detection)		
		Pre-wired	M8 Connector	
Item	Model	NPN output	E3Z-L63-UL	E3Z-L68-UL
		PNP output	E3Z-L83-UL	E3Z-L88-UL
Sensing distance		30±20 mm (transparent glasses 100 × 100 mm)		
Spot diameter (reference value)		2-mm dia. min. (at sensing distance of 30 mm)		
Minimum detectable object (reference value)		0.1 mm dia. (copper wire)		
Light source (wavelength)		Red LED (660 nm)		
Current consumption		30 mA max.		
Protection circuits		Power supply reverse polarity protection, Output short-circuit protection, Mutual interference prevention, Reverse output polarity protection		
Response time		Operate or reset: 1 ms max.		
Sensitivity adjustment		One-turn adjuster		
Degree of protection		IP67 (IEC 60529)		
Connection method		Pre-wired (standard cable length: 2 m) / M8 (4-pin) Connector		
Weight (packed state)	Pre-wired cable (2 m)	Approx. 65 g		
	M8 Connector	Approx. 20 g		
Material	Case	PBT (polybutylene terephthalate)		
	Display	Polycarbonate (PC)		
	Lens	Modified polyarylate		

Sensing method		Retro-reflective for clear, plastic bottles (without MSR function)				
		Pre-wired	M8 Connector	Pre-wired	M8 Connector	
Item	Model	NPN output	E3Z-B61-UL	E3Z-B66-UL	E3Z-B62-UL	E3Z-B67-UL
		PNP output	E3Z-B81-UL	E3Z-B86-UL	E3Z-B82-UL	E3Z-B87-UL
Sensing distance		500 mm (80 mm) *1 (using E39-R1S)		2 m (500 mm) *1 *2 (using E39-R1S)		
Standard sensing object		Opaque materials, 75mm dia. min. (Standard detectable object :glass Cylinder 15mm dia. thickness 1.1mm length 50mm, and the transmission factor 92% or less in wave length 660nm)				
Light source (wavelength)		Red LED (660 nm)				
Current consumption		30 mA max.				
Protection circuits		Reversed power supply polarity protection, Output short-circuit protection, Mutual interference prevention, and Reversed output polarity protection				
Response time		Operate or reset: 1 ms max.				
Sensitivity adjustment		One-turn adjuster				
Degree of protection		IP67 (IEC 60529)				
Connection method		Pre-wired (standard cable length: 2 m) / M8 (4-pin) Connector				
Weight (packed state)	Pre-wired cable (2 m)	Approx. 65 g				
	M8 Connector	Approx. 20 g				
Material	Case	PBT (polybutylene terephthalate)				
	Display	Polycarbonate (PC)				
	Lens	Modified polyarylate				

*1. Values in parentheses indicate the minimum required distances between the Sensors and Reflectors.

*2. Plastic bottles must pass with the minimum clearance of 500 mm.

Common (Transparent glass Limited-reflective / Retro-reflective for clear, plastic bottles)

Power supply voltage	12 to 24 VDC ±10%, ripple (p-p): 10% max. Class 2
Control output	Load power supply voltage: 26.4 VDC max., Load current: 100 mA max. (Residual voltage: Load current of less than 10 mA: 1 V max. Load current of 10 to 100 mA: 2 V max.) Open collector output (NPN/PNP depending on model) Light-ON/Dark-ON selectable
Ambient illumination (Receiver side)	Incandescent lamp: 3,000 lx max. Sunlight: 10,000 lx max.
Ambient temperature range	Operating: -25 to 55°C (with no icing or condensation) Storage: -40 to 70°C (with no icing or condensation)
Ambient humidity range	Operating: 35% to 85%, Storage: 35% to 95% (with no condensation)
Insulation resistance	20 MΩ min. at 500 VDC
Dielectric strength	1,000 VAC, 50/60 Hz for 1 min
Vibration resistance	Destruction: 10 to 55 Hz, 1.5 mm double amplitude for 2 hours each in X, Y, and Z directions
Shock resistance	Destruction: 500 m/s ² 3 times each in X, Y, and Z directions
Indicator	Operation indicator (orange) Stability indicator (green) Through-beam Emitter has power indicator (orange) only.
Accessories	Instruction manual (Neither Reflectors nor Mounting Brackets are provided with any of the above models.)

Note: 1. Altitude: Up to 2000 m, Pollution degree: 3, Enclosure type: Type1.

Laser Model

Sensing method		Through-beam	Retro-reflective with MSR function	Distance-settable (BGS models)		
Response		Standard response			High-speed response	
Model	NPN output	Pre-wired	E3Z-LT61-UL	E3Z-LR61-UL	E3Z-LL61-UL	E3Z-LL63-UL
		M8 Connector	E3Z-LT66-UL	E3Z-LR66-UL	E3Z-LL66-UL	E3Z-LL68-UL
Item	PNP output	Pre-wired	E3Z-LT81-UL	E3Z-LR81-UL	E3Z-LL81-UL	E3Z-LL83-UL
		M8 Connector	E3Z-LT86-UL	E3Z-LR86-UL	E3Z-LL86-UL	E3Z-LL88-UL
Sensing distance		60 m	0.2 to 7 m (when using E39-R12)	White paper (100 × 100 mm): 20 to 300 mm Black paper (100 × 100 mm): 20 to 160 mm	White paper (100 × 100 mm): 25 to 300 mm Black paper (100 × 100 mm): 25 to 100 mm	
Set distance range		—		White paper (100 × 100 mm): 40 to 300 mm Black paper (100 × 100 mm): 40 to 160 mm	White paper (100 × 100 mm): 40 to 300 mm Black paper (100 × 100 mm): 40 to 100 mm	
Spot diameter (reference value)		5-mm dia. at 3 m		0.5-mm dia. at 300 mm		
Standard sensing object		Opaque: 12-mm dia. min.	Opaque: 75-mm dia. min.	—		
Minimum detectable object (reference value)		6-mm-dia. opaque object at 3 m		0.2-mm-dia. stainless-steel pin gauge at 300 mm		
Differential travel		---		5% max. of set distance		
Black/white error		—		5% at 160 mm	5% at 100 mm	
Directional angle		Receiver: 3 to 15°	—			
Light source (wavelength)		Red LD (655 nm), JIS Class 1, IEC Class 1, FDA Class 1				
Power supply voltage		12 to 24 VDC ±10%, ripple (p-p): 10% max. Class 2				
Current consumption		35 mA (Emitter 15 mA, Receiver 20 mA)	30 mA max.			
Control output		Load power supply voltage: 26.4 VDC max., Load current: 100 mA max., Open collector output				
Residual output voltage		Load current of less than 10 mA: 1 V max. Load current of 10 to 100 mA: 2 V max.				
Output mode switching		Switch to change between light-ON and dark-ON				
Protection circuits		Reversed power supply polarity protection, Output short-circuit protection, and Reversed output polarity protection	Reversed power supply polarity protection, Output short-circuit protection, Mutual interference prevention, and Reversed output polarity protection			
Response time		Operate or reset: 1 ms max.			Operate or reset: 0.5 ms max.	
Sensitivity adjustment		One-turn adjuster		Five-turn endless adjuster		
Ambient illumination (Receiver side)		Incandescent lamp: 3,000 lx max. Sunlight: 10,000 lx max.				
Ambient temperature range		Operating: -10 to 55°C, Storage: -25 to 70°C (with no icing or condensation)				
Ambient humidity range		Operating: 35% to 85%, Storage: 35% to 95% (with no icing or condensation)				
Insulation resistance		20 MΩ min. at 500 VDC				
Dielectric strength		1,000 VAC, 50/60 Hz for 1 min				
Vibration resistance		Destruction: 10 to 55 Hz, 1.5-mm double amplitude for 2 hours each in X, Y, and Z directions				
Shock resistance		Destruction: 500 m/s ² 3 times each in X, Y, and Z directions				
Degree of protection		IP67 (IEC 60529)				
Connection method		Pre-wired (standard cable length: 2 m) / M8 (4-pin) Connector				
Indicator		Operation indicator (orange) Stability indicator (green) Emitter for Through-beam Models has power indicator (orange) only.				
Weight (packed state)	Pre-wired cable (2 m)	Approx. 120 g	Approx. 65 g			
	M8 Connector	Approx. 30 g	Approx. 20 g			
Material	Case	PBT (polybutylene terephthalate)				
	Display	Polycarbonate (PC)				
	Lens	Modified polyarylate resin	Methacrylic resin	Modified polyarylate resin		
Accessories		Instruction manual (Neither Reflectors nor Mounting Brackets are provided with any of the above models.)				

Note: 1. Altitude: Up to 2000 m, Pollution degree: 3, Enclosure type: Type1.

IO-Link Model

Item	Model	Sensing method		Through-beam	Retro-reflective with MSR function	Diffuse-reflective	Narrow-beam Models
		PNP output	Pre-wired	E3Z-T81-IL□-UL	E3Z-R81-IL□-UL	E3Z-D82-IL□-UL	E3Z-L81-IL□-UL
		M8 Connector		E3Z-T86-IL□-UL	E3Z-R86-IL□-UL	E3Z-D87-IL□-UL	E3Z-L86-IL□-UL
Sensing distance		15 m		4 m (100 mm) *1 (when using E39-R1S) 3 m (100 mm) *1 (when using E39-R1)	1 m (white paper: 300 × 300 mm)	90 + 30 mm (white paper: 100 × 100 mm)	
Spot diameter (reference value)		—		—		2.5 dia. and sensing distance of 90 mm	
Standard sensing object		Opaque: 12-mm dia. min.		Opaque: 75-mm dia. min.	—		
Minimum detectable object (reference value)		—		—			0.1 mm (copper wire)
Differential travel (representative example)		---		---	20% max. of setting distance	Refer to <i>Engineering data</i> on page 22.	
Directional angle		Both emitter and receiver: 3 to 15°		2 to 10°	---		
Light source (wavelength)		Infrared LED (870 nm)		Red LED (660 nm)	Infrared LED (870 nm)	Red LED (650 nm)	
Power supply voltage		10 to 30 VDC including ripple (p-p) Class 2					
Current consumption		50 mA max. (Emitter: 25 mA max., Receiver: 25 mA max.)		30 mA max.			
Control output		Load power supply voltage: 30 VDC max., Load current: 100 mA max. Residual voltage: Load current of less than 10 mA: 1 V max. Load current of 10 to 100 mA: 2 V max. PNP open collector output Light-ON/Dark-ON selectable					
Indicators		In the Standard I/O mode (SIO mode): Operation indicator (orange, lit) and stability indicator (green, lit) In the IO-Link Mode: Operation indicator (orange, lit) and communication indicator (green, blinking at 1 s intervals)					
Protection circuits		Reversed power supply polarity protection, output short-circuit protection, and reversed output polarity protection		Reversed power supply polarity protection, output short-circuit protection, reversed output polarity protection, and mutual interference prevention			
Response time		Operate or reset: 1 ms max.					
Sensitivity adjustment		Sensitivity adjuster / IO-Link communications					
Ambient illumination (Receiver side)		Incandescent lamp: 3,000 lx max. Sunlight: 10,000 lx max.					
Ambient temperature range		Operating: -25 to 55°C (with no icing or condensation) Storage: -40 to 70°C (with no icing or condensation)					
Ambient humidity range		Operating: 35% to 85%, Storage: 35% to 95% (with no condensation)					
Insulation resistance		20 MΩ min. at 500 VDC					
Dielectric strength		1,000 VAC, 50/60 Hz for 1 min					
Vibration resistance		Destruction: 10 to 55 Hz, 1.5 mm double amplitude for 2 hours each in X, Y, and Z directions					
Shock resistance		Destruction: 500 m/s ² 3 times each in X, Y, and Z directions					
Degree of protection		IEC 60529 IP67					
Connection method		Pre-wired (standard cable length: 2 m) / M8 (4-pin) Connector					
Weight (packed state)	Pre-wired cable (2 m)	Approx. 120 g		Approx. 65 g			
	M8 Connector	Approx. 30 g		Approx. 20 g			
Material	Case	Polybutylene terephthalate (PBT)					
	Display	Polycarbonate (PC)					
	Lens	Modified polyarylate	Methacrylate resin	Modified polyarylate			
Main IO-Link functions		Operation mode switching between Light ON and Dark ON, setup of the instability detection level for light receiving and non-light receiving, timer function of the control output and timer time selecting, instability output (IO-Link mode) ON delay timer time selecting, setup of a teaching level and execution of teaching, setup of light receiving sensitivity level, monitor output, operating hours read-out, and initial reset					
Communication specifications	IO-Link specification	Ver 1.1					
	Baud rate	-IL3: COM3 (230.4 kbps), -IL2: COM2 (38.4 kbps)					
	Data length	PD size: 2 bytes, OD size: 1 byte (M-sequence type: TYPE_2_2)					
	Minimum cycle time	-IL3 (COM3): 1 ms, -IL2 (COM2): 2.3 ms					
Accessories		Instruction manual (Neither Reflectors nor Mounting Brackets are provided with any of the above models.)					

Note: 1. Altitude: Up to 2000 m, Pollution degree: 3, Enclosure type: Type1.

*1. Values in parentheses indicate the minimum required distance between the Sensor and Reflector.

Standard Model

Parallel Operating Range

Through-beam Models

E3Z-T□1(T□6)

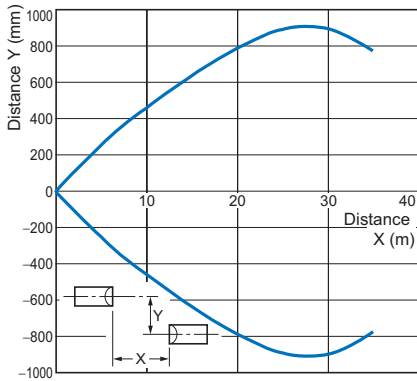

Through-beam Models

E3Z-T□A

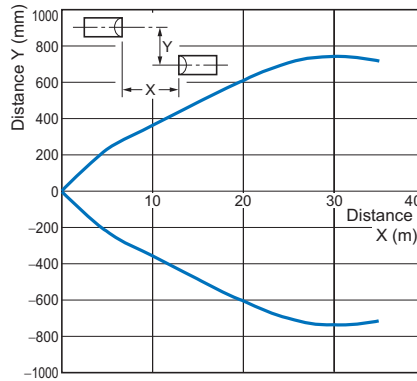

Through-beam Models

E3Z-T□2(T□7)

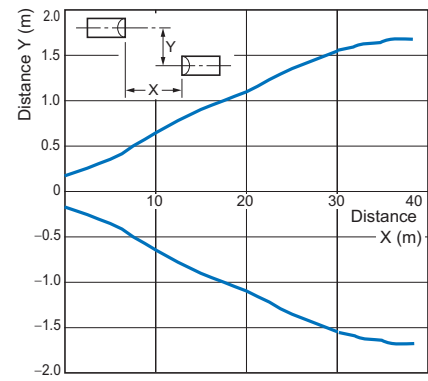

Through-beam Models

E3Z-T□1(T□6) and Slit
(A Slit is mounted to the Emitter and Receiver.)

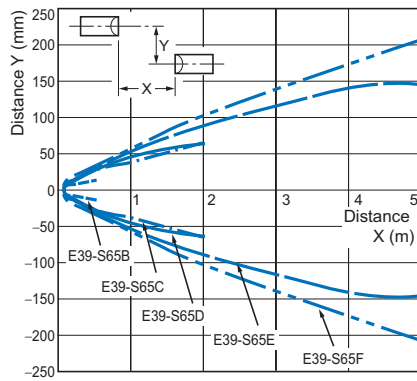

Through-beam Models

E3Z-T□A and Slit
(A Slit is mounted to the Emitter and Receiver.)

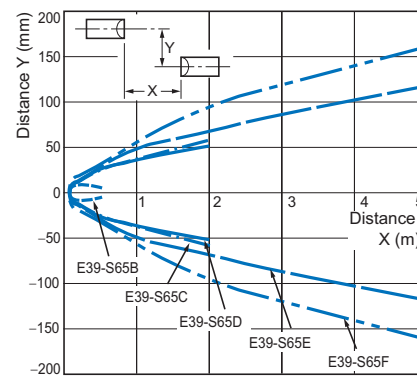

Retro-reflective Models

E3Z-R□1(R□6) and Reflector

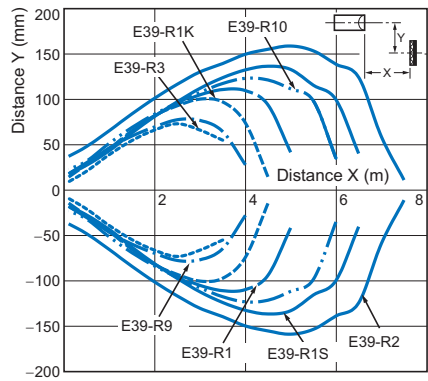

Retro-reflective Models

E3Z-B□1/B□6 + E39-R1S Reflector
(Order Separately)

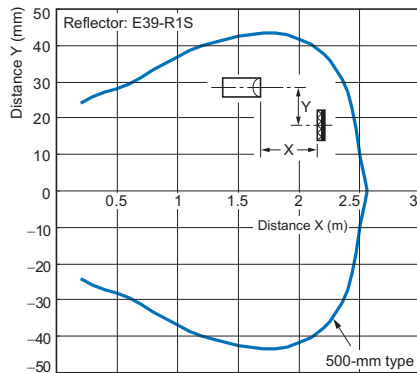

Retro-reflective Models

E3Z-B□2/B□7 + E39-R1S Reflector
(Order Separately)

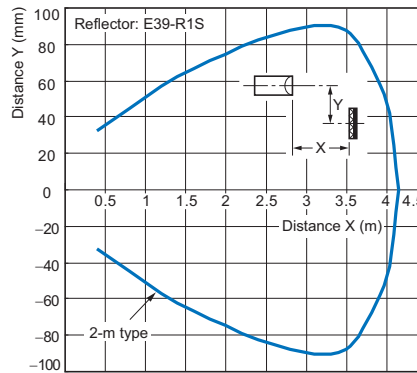

Operating Range

Diffuse-reflective Models

E3Z-D□1(D□6)

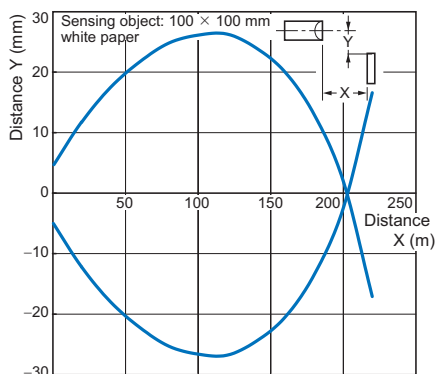

Diffuse-reflective Models

E3Z-D□2(D□7)

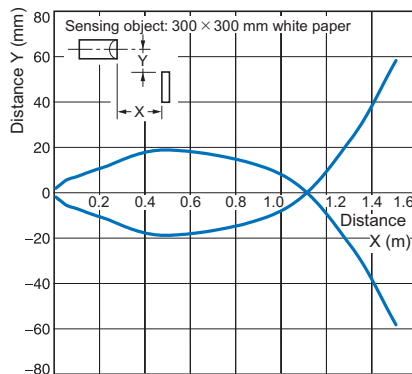

Narrow-beam Reflective Models

E3Z-L□1(L□6)

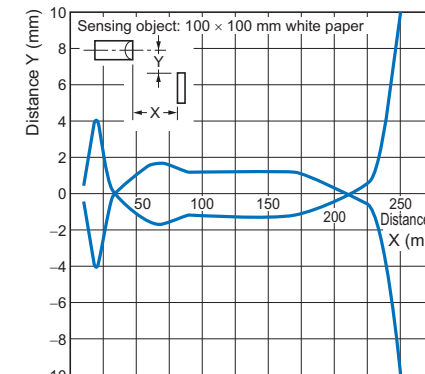

Distance-settable Models

E3Z-LS□1/LS□6

BGS

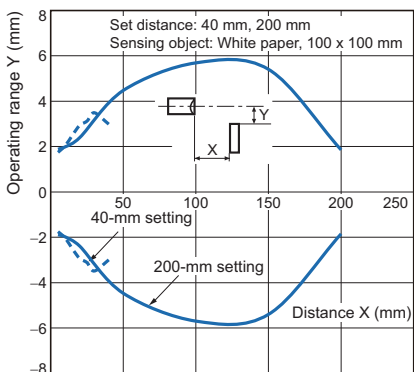

FGS

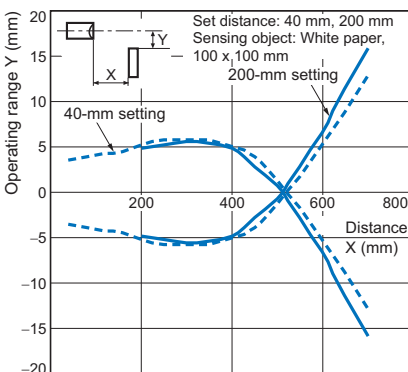

Distance-settable Models

E3Z-LS□3/LS□8

BGS

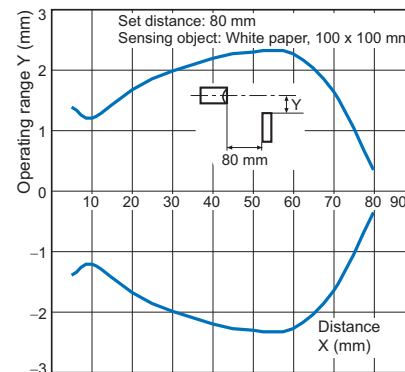

Excess Gain vs. Set Distance

Through-beam Models

E3Z-T□1(T□6)/-T□A/-T□2(T□7)

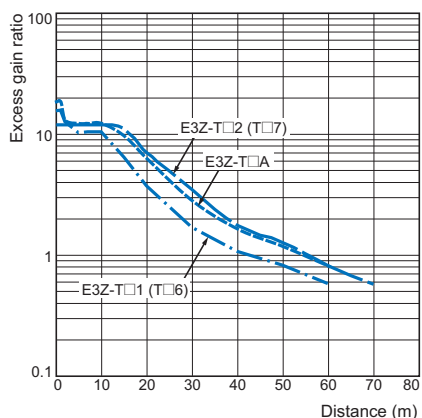

Retro-reflective Models

E3Z-R□1(R□6) and Reflector

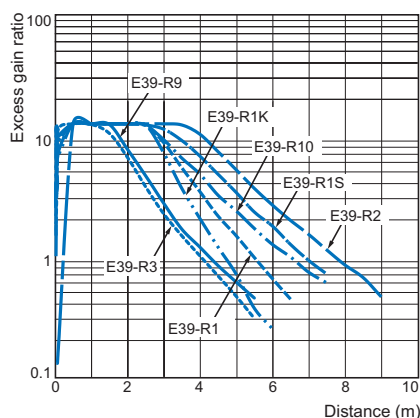

Diffuse-reflective Models

E3Z-D□1(D□6)

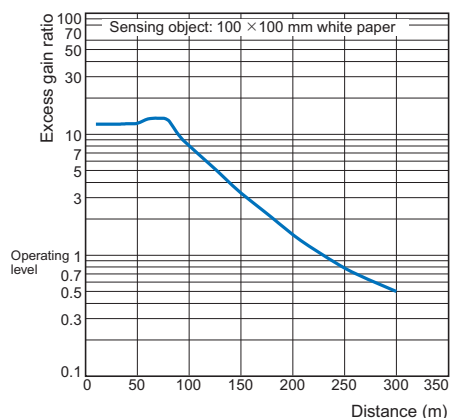

Excess Gain vs. Set Distance

Diffuse-reflective Models

E3Z-D□2(D□7)

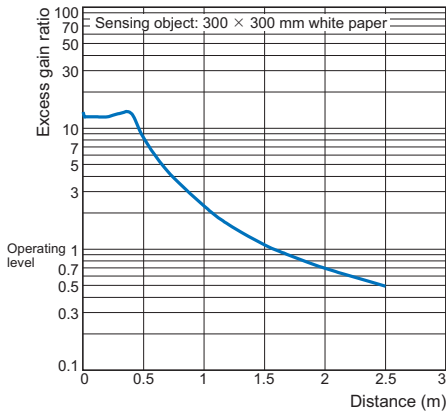

Narrow-beam Reflective Models

E3Z-L□1(L□6)

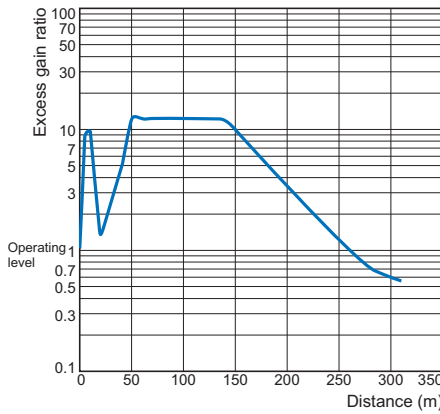

Limited reflective Models

E3Z-L□3(L□8)

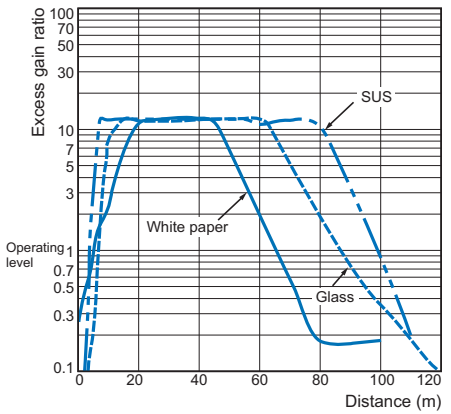

Retro-reflective Models

E3Z-B□1/B□6 + E39-R1S Reflector (Order Separately)

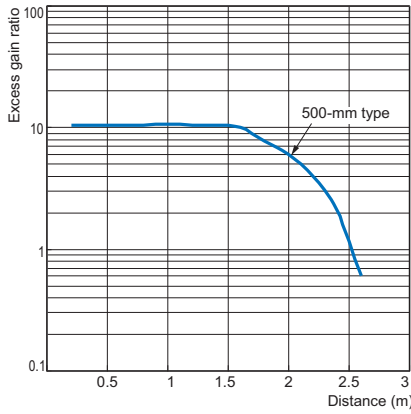

Retro-reflective Models

E3Z-B□2/B□7 + E39-R1S Reflector (Order Separately)

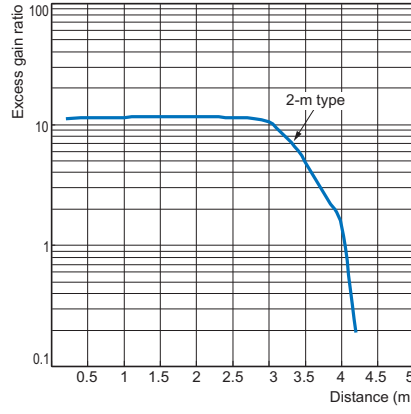

Sensing Object Size vs. Sensing Distance

Diffuse-reflective Models

E3Z-D□1(D□6)

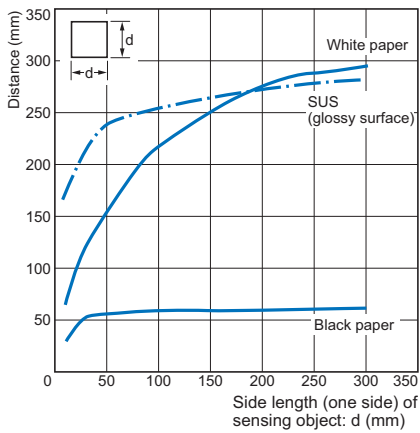

Diffuse-reflective Models

E3Z-D□2(D□7)

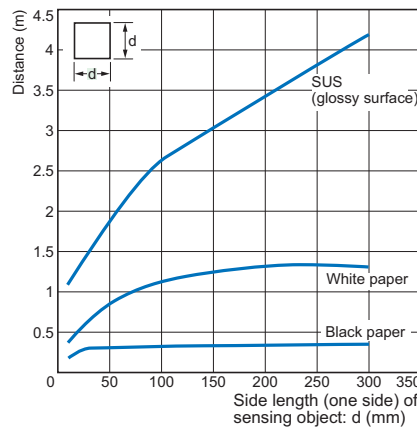

Narrow-beam Reflective Models

E3Z-L□1(L□6)

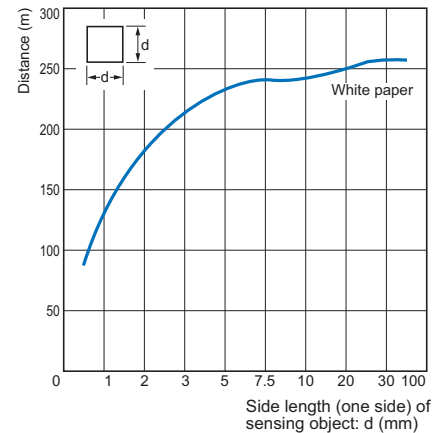

Spot Diameter vs. Sensing Distance

Narrow-beam Reflective Models

E3Z-L□1(L□6)

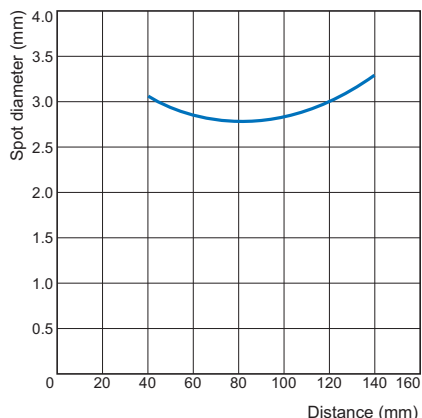

Distance-settable Models

E3Z-LS□1/LS□6

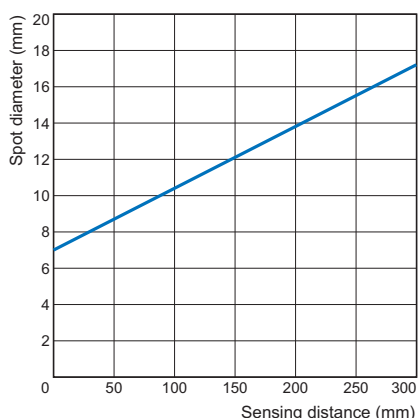

Distance-settable Models

E3Z-LS□3/LS□8

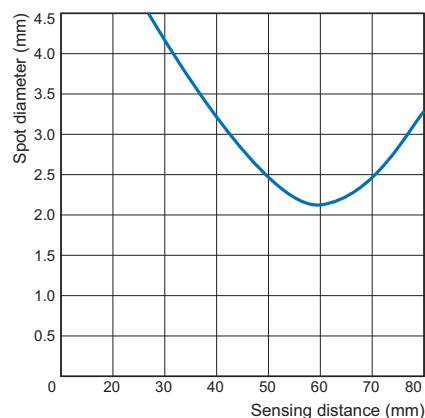

Differential Travel vs. Sensing Distance

Narrow-beam Reflective Models

E3Z-L□1(L□6)

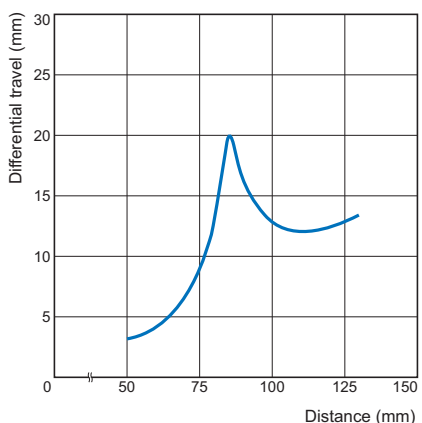

Distance-settable Models

E3Z-LS□1/LS□6

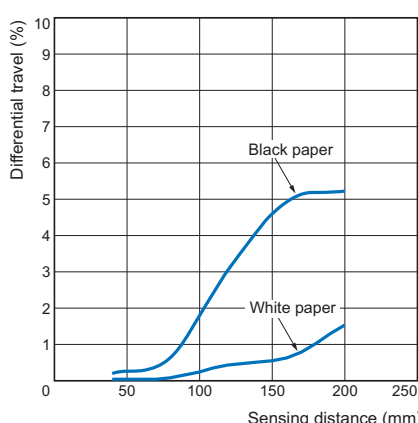

Distance-settable Models

E3Z-LS□3/LS□8

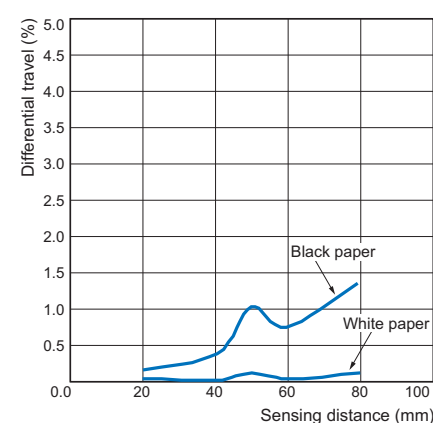

Close-range Characteristics

Distance-settable Models

E3Z-LS□1/LS□6

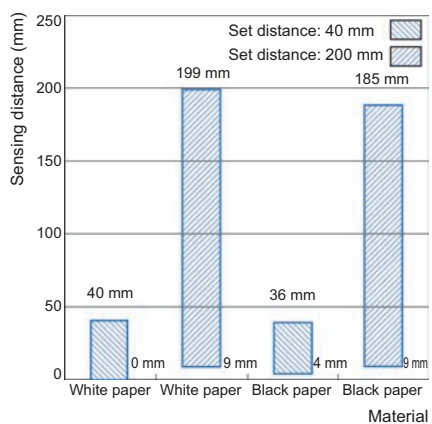

Distance-settable Models

E3Z-LS□3/LS□8

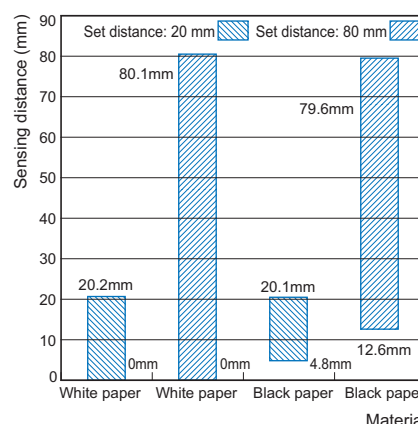

Sensing Object Angle Characteristics

Distance-settable Models

E3Z-LS□1/LS□6

Vertical

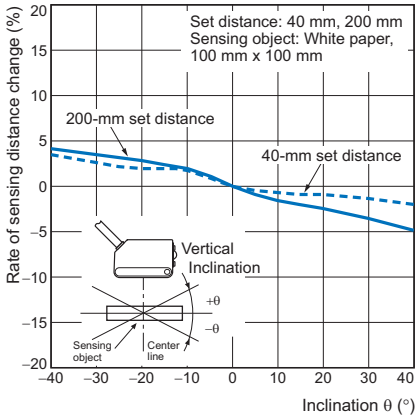

Horizontal

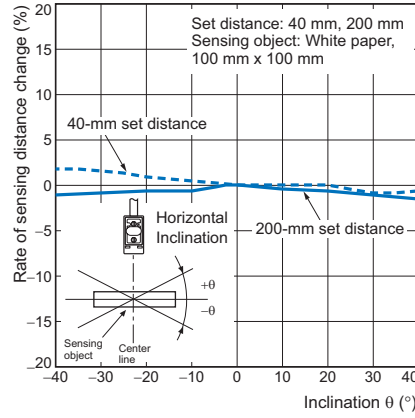

Distance-settable Models

E3Z-LS□3/LS□8

Vertical

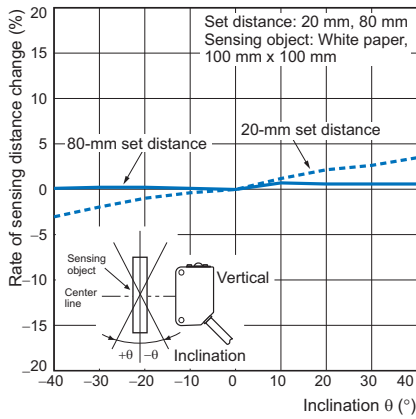

Horizontal

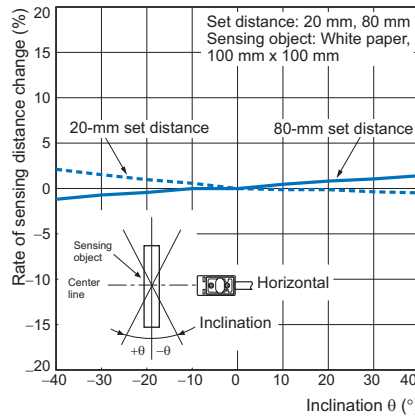

FGS Mode Set Distance

Distance-settable Models

E3Z-LS□1/LS□6

White Paper

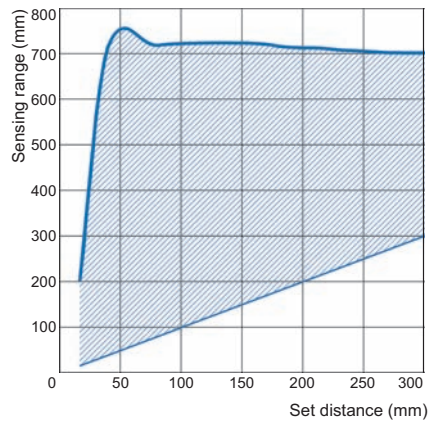

Black Paper

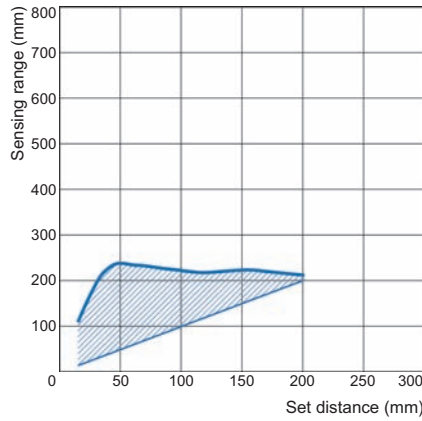

Sensing Distance vs. Sensing Object Material

Distance-settable Models

E3Z-LS□1/LS□6

Set Distance of 40 mm using White Paper

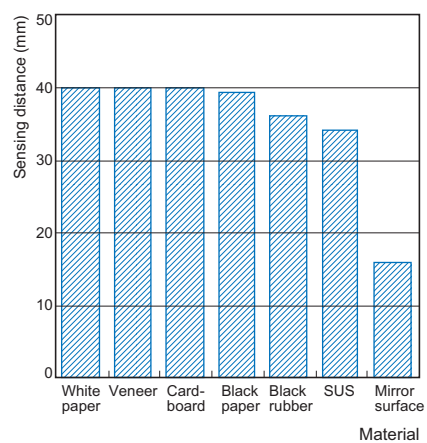

Set Distance of 200 mm using White Paper

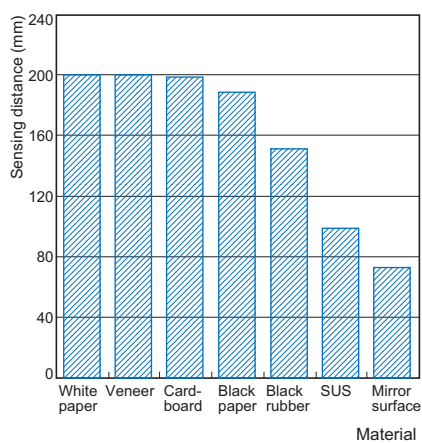

Distance-settable Models

E3Z-LS□3/LS□8

Set Distance of 20 mm using White Paper

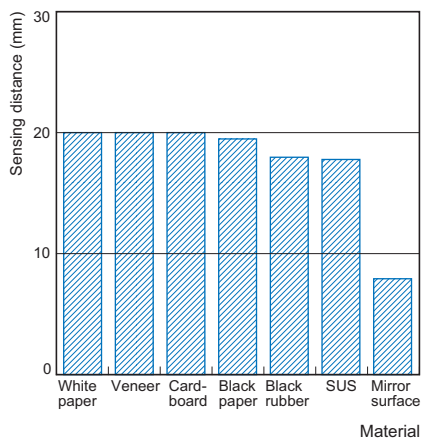

Set Distance of 80 mm using White Paper

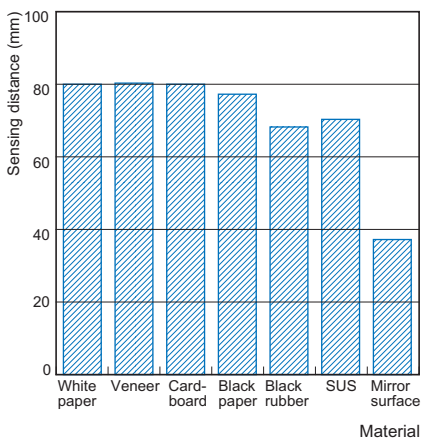

Laser Model

Parallel Operating Range

Through-beam Models

E3Z-LT□□

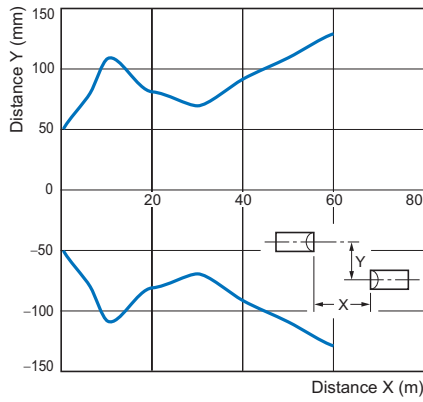

Through-beam Models

E3Z-LT□□ + E39-S65A

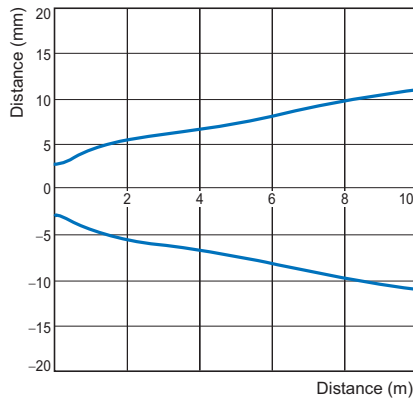

Retro-reflective Models

E3Z-LR□□

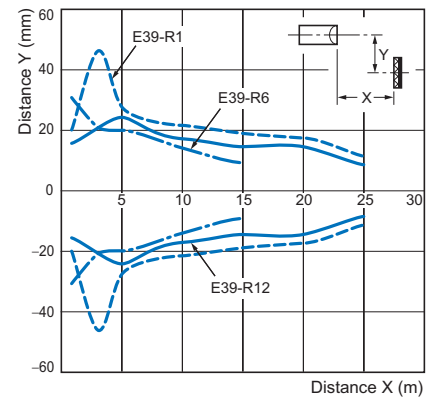

Operating Range at a Set Distance of 300 mm

Distance-settable Models

E3Z-LL□□

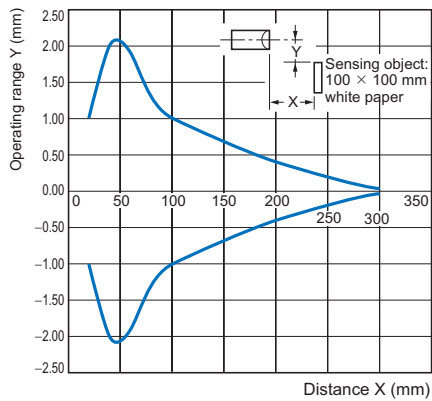

Operating Range at a Set Distance of 40 mm

Distance-settable Models

E3Z-LL□□

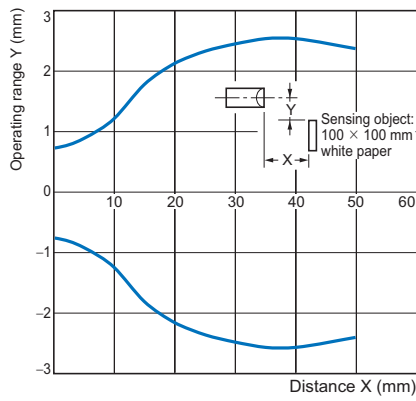

Excess Gain vs. Set Distance

Through-beam Models

E3Z-LT□□

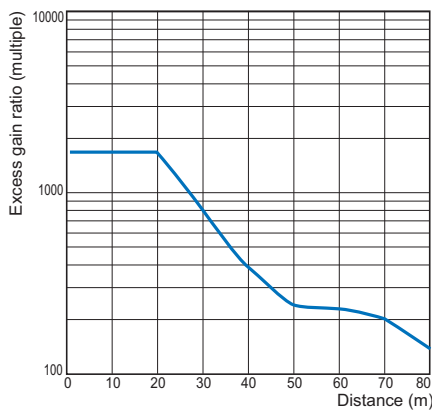

Retro-reflective Models

E3Z-LR□□

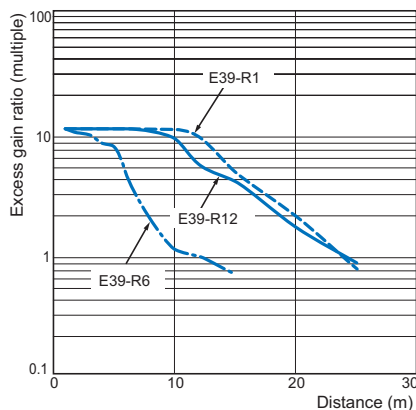

Emission Spot Diameter vs. Distance

Through-beam and Retro-reflective Models (Same for All Models)

E3Z-LT□□, E3Z-LR□□

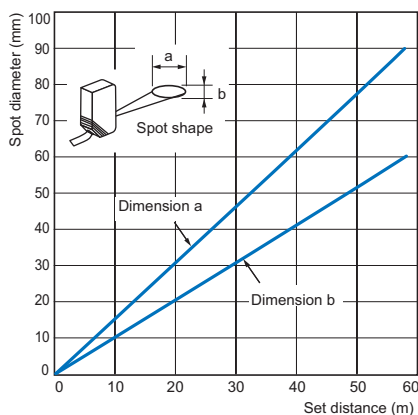

Distance-settable Models (Same for All Models)

E3Z-LL□□

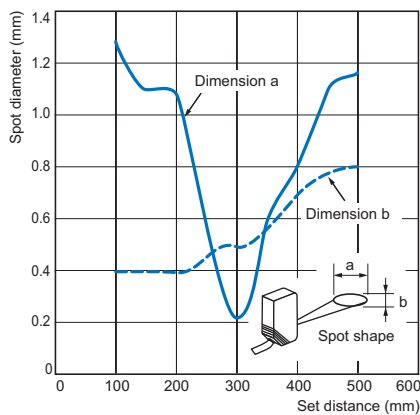

Hysteresis vs. Distance

Distance-settable Models

E3Z-LL□1 (LL□6)

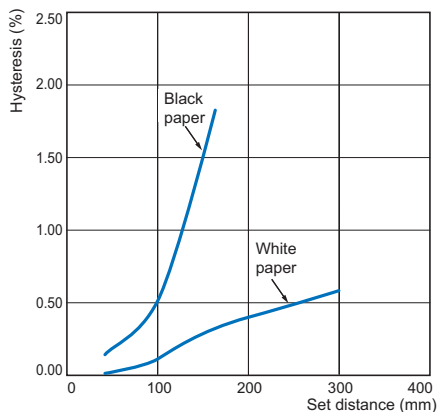

E3Z-LL□3 (LL□8)

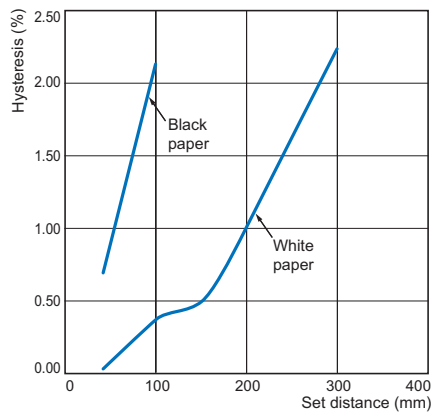

Close Range Characteristics

Distance-settable Models

E3Z-LL□1/LL□6

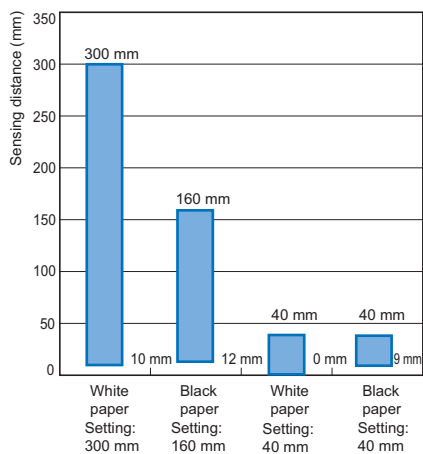

E3Z-LL□3/LL□8

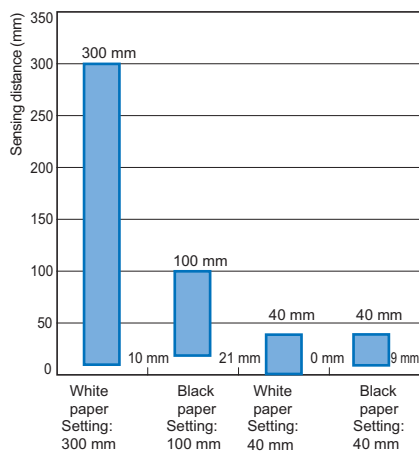

Sensing Distance vs. Sensing Object Material

Distance-settable Models

E3Z-LL□1/-LL□6

White Paper with a Set Distance of 40 mm

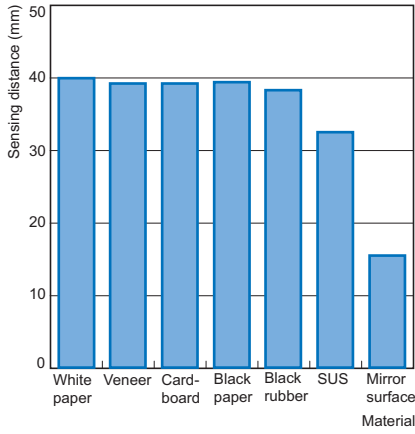

E3Z-LL□3/-LL□8

White Paper with a Set Distance of 40 mm

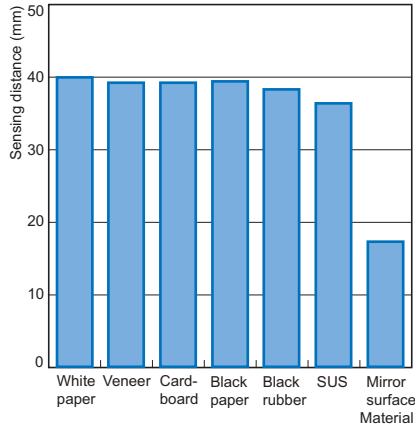

E3Z-LL□1/-LL□6

White Paper with a Set Distance of 300 mm

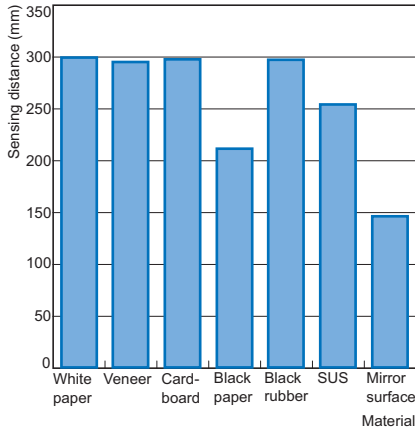

E3Z-LL□3/-LL□8

White Paper with a Set Distance of 100 mm

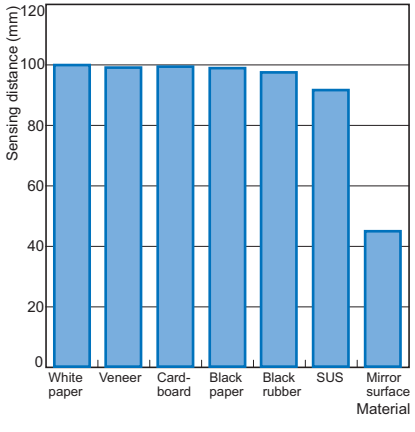

Inclination Characteristics (Vertical)

Distance-settable Models

E3Z-LL□□

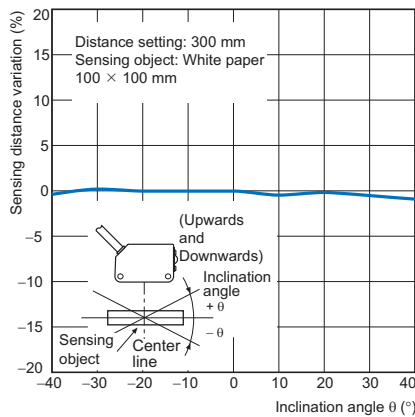

Inclination Characteristics (Horizontal)

Distance-settable Models

E3Z-LL□□

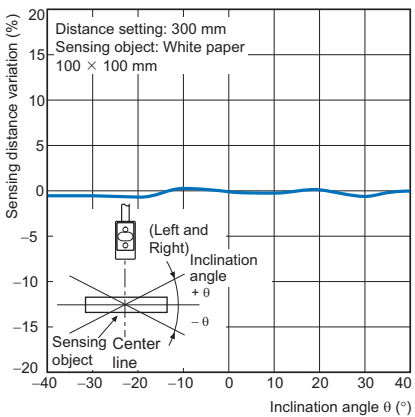

IO-Link Model

Parallel Operating Range

Through-beam Models

E3Z-T8□-IL□

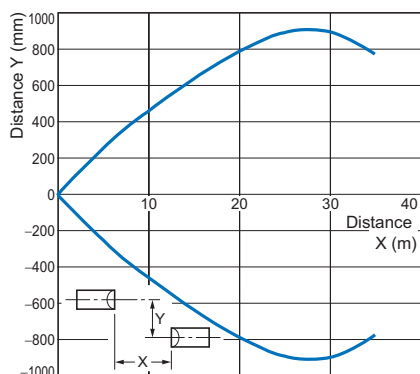

Through-beam Models

E3Z-T8□-IL□ and Slit

(A Slit is mounted to the Emitter and Receiver.)

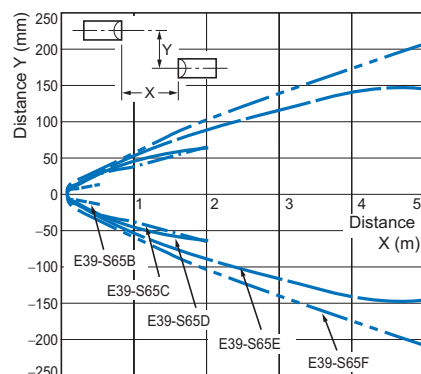

Retro-reflective Models

E3Z-R8□-IL□ and Reflector

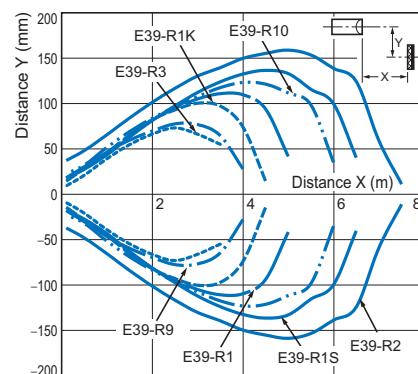

Operating Range

Diffuse-reflective Models

E3Z-D8□-IL□

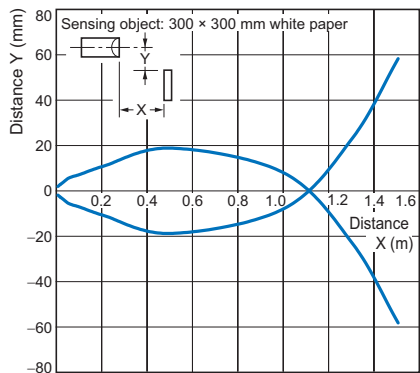

Narrow-beam Reflective Models

E3Z-L8□-IL□

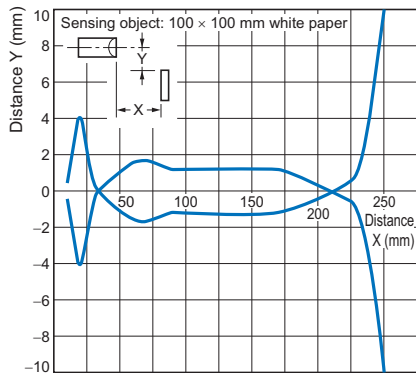

Monitor Output vs. Sensing Distance

Through-beam Models

E3Z-T8□-IL□

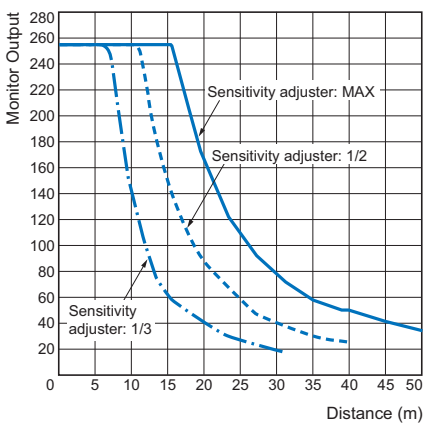

Retro-reflective Models

E3Z-R8□-IL□ and E39-R1 Reflector

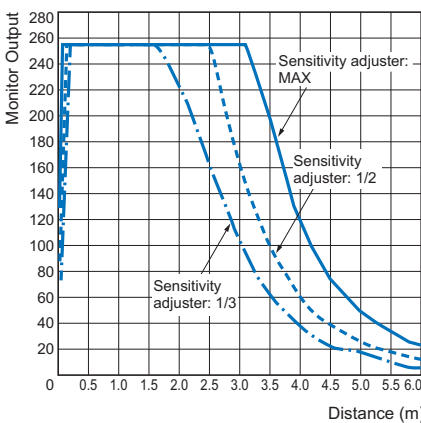

Monitor Output vs. Sensing Distance

Diffuse-reflective Models

E3Z-D8□-IL□

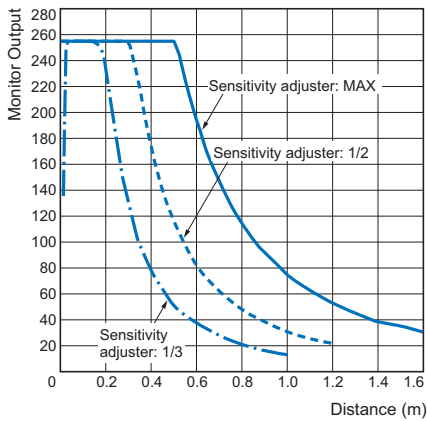

Narrow-beam Reflective Models

E3Z-L8□-IL□

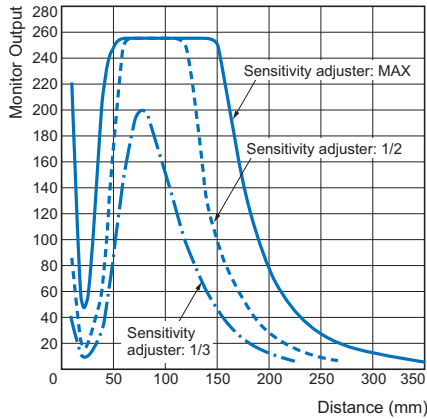

Sensing Object Size vs. Sensing Distance

Diffuse-reflective Models

E3Z-D8□-IL□

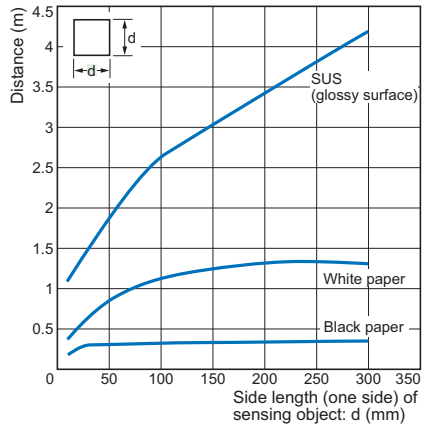

Narrow-beam Reflective Models

E3Z-L8□-IL□

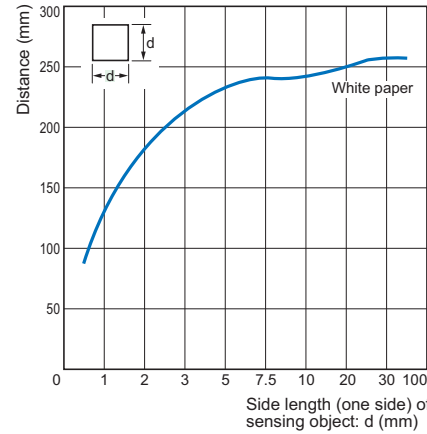

Spot Diameter vs. Sensing Distance

Narrow-beam Reflective Models

E3Z-L8□-IL□

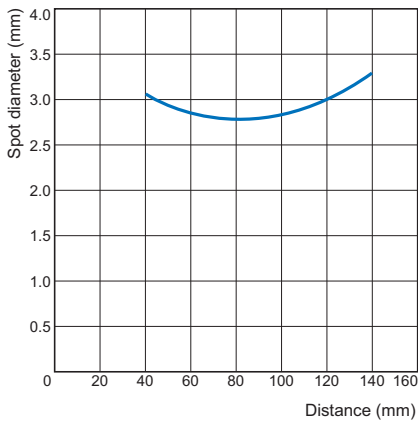

Differential Travel vs. Sensing Distance

Narrow-beam Reflective Models

E3Z-L8□-IL□

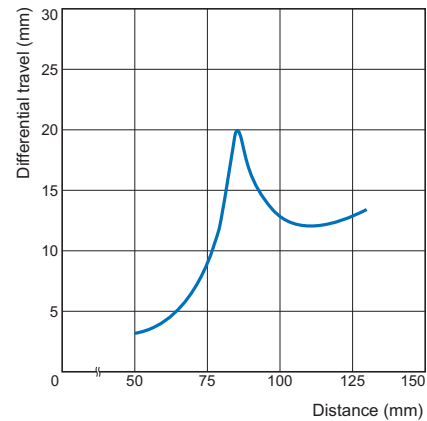

I/O Circuit Diagrams

Standard Model (Through-beam / Retro-reflective / Diffuse-reflective / Limited reflective)

NPN Output

Model*	Operation mode	Timing charts	Operation selector	Output circuit
E3Z-T6□(A) E3Z-R6□ E3Z-D6□ E3Z-L6□ E3Z-B6□ E3Z-LT6□ E3Z-LR6□	Light-ON		L side (LIGHT ON)	<p>Through-beam Receivers, Retro-reflective Models, Diffuse-reflective Models, Limited reflective Models.</p> <p>Connector Pin Arrangement</p> <p>M8 Connector: </p> <p>M12 Pre-wired Smartclick Connector: </p>
	Dark-ON		D side (DARK ON)	
Through-beam Emitter				<p>Connector Pin Arrangement</p> <p>M8 Connector: </p> <p>M12 Pre-wired Smartclick Connector: </p>

PNP Output

Model*	Operation mode	Timing charts	Operation selector	Output circuit
E3Z-T8□(A) E3Z-R8□ E3Z-D8□ E3Z-L8□ E3Z-B8□ E3Z-LT8□ E3Z-LR8□	Light-ON		L side (LIGHT ON)	<p>Through-beam Receivers, Retro-reflective Models, Diffuse-reflective Models, Limited reflective Models.</p> <p>Connector Pin Arrangement</p> <p>M8 Connector: </p> <p>M12 Pre-wired Smartclick Connector: </p>
	Dark-ON		D side (DARK ON)	
Through-beam Emitter				<p>Connector Pin Arrangement</p> <p>M8 Connector: </p> <p>M12 Pre-wired Smartclick Connector: </p>

* Models numbers for Through-beam Sensors (E3Z-T□□, E3Z-LT□□) are for sets that include both the Emitter and Receiver. The model number of the Emitter is expressed by adding "-L" to the set model number (example: E3Z-T61-L-UL 2M), the model number of the Receiver, by adding "-D" (example: E3Z-T61-D-UL 2M). Refer to *Ordering Information* to confirm model numbers for Emitter and Receivers.

Plugs (Sensor I/O Connectors)

M8 Connector

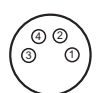

XS3F-M421-402-R XS3F-M421-402-L
XS3F-M421-405-R XS3F-M421-405-L
XS3F-M422-402-R XS3F-M422-402-L
XS3F-M422-405-R XS3F-M422-405-L

M12 Smartclick Connector

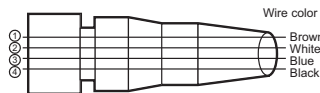
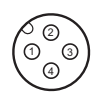

XS5F-D421-D80-F XS5F-D421-G80-F
XS5F-D422-D80-F XS5F-D422-G80-F

Pin arrangement

Classification	Wire color	Connector pin No.	Application
DC	Brown	1	Power supply (+V)
	White	2	-
	Blue	3	Power supply (0 V)
	Black	4	Output

Note: Pin 2 is not used.

Standard Model and Laser Model (Distance-settable)

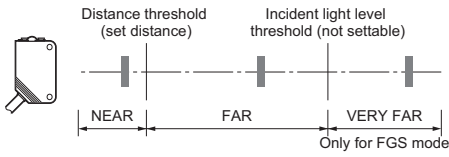

Note: The VERY FAR region is supported only for FGS. The incident light level threshold is fixed and cannot be set.

NPN Output

Model	Operation mode	Timing charts	Operation selector	BGS/FGS selection method	Output circuit
E3Z-LS61 E3Z-LS66 E3Z-LS63 E3Z-LS68 E3Z-LL61 *1 E3Z-LL66 *1 E3Z-LL63 *1 E3Z-LL68 *1	Light-ON		L side (LIGHT ON)	BGS: Either leave the pink wire (2) open or connect it to the blue wire (3).	
	Dark-ON		D side (DARK ON)		
E3Z-LS61 E3Z-LS66	Light-ON		L side (LIGHT ON)	FGS: Connect the pink wire (2) to the brown wire (1).	<p>Connector Pin Arrangement M8 Connector</p>
	Dark-ON		D side (DARK ON)		

*1. Connector terminal 2 and pink connection wire are not included.

PNP Output

Model	Operation mode	Timing charts	Operation selector	BGS/FGS selection method	Output circuit
E3Z-LS81 E3Z-LS86 E3Z-LS83 E3Z-LS88 E3Z-LL81 *1 E3Z-LL86 *1 E3Z-LL83 *1 E3Z-LL88 *1	Light-ON		L side (LIGHT ON)	BGS: Either leave the pink wire (2) open or connect it to the blue wire (3).	
	Dark-ON		D side (DARK ON)		
E3Z-LS81 E3Z-LS86	Light-ON		L side (LIGHT ON)	FGS: Connect the pink wire (2) to the brown wire (1).	<p>Connector Pin Arrangement</p> <p>M8 Connector</p>
	Dark-ON		D side (DARK ON)		

*1. Connector terminal 2 and pink connection wire are not included.

Plugs (Sensor I/O Connectors)

M8 Connector

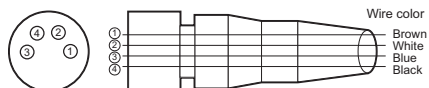

- | | |
|-----------------|-----------------|
| XS3F-M421-402-R | XS3F-M421-402-L |
| XS3F-M421-405-R | XS3F-M421-405-L |
| XS3F-M422-402-R | XS3F-M422-402-L |
| XS3F-M422-405-R | XS3F-M422-405-L |

Pin arrangement

Classification	Wire color	Connector pin No.	Application
DC	Brown	1	Power supply (+V)
	White	2	BGS/FGS selection
	Blue	3	Power supply (0 V)
	Black	4	Output

IO-Link Model (Through-beam / Retro-reflective / Diffuse-reflective)

Timing Chart

Output mode	Operation mode *1	Stable operation zone	Unstable operation zone	Stable operation zone	Signal States
Standard I/O mode (SIO mode)	L ON	ON	ON	ON	Stability indicator (green) *5 ON
		OFF	OFF	OFF	Operation indicator (orange) ON
		ON	ON	ON	Control output 1 *2 ON
	D ON	ON	ON	ON	Stability indicator (green) *5 ON
		OFF	OFF	OFF	Operation indicator (orange) ON
		ON	ON	ON	Control output 1 *2 ON
IO-Link mode	L ON	ON	ON	ON	Flashing (1 s cycle) Communication indicator (green) ON
		OFF	OFF	OFF	Operation indicator (orange) OFF
		ON	ON	ON	Control output 1 (Byte1_bit0) *2 1
	D ON	ON	ON	ON	Control output 2 *2 *3 0
		OFF	OFF	OFF	Instability detection (Light receiving) (Byte1_bit4) *4 *5 1
		ON	ON	ON	Instability detection (Non-light receiving) (Byte1_bit3) *4 *5 0

Note: Please contact your OMRON sales representative regarding assignment of data.

*1. The operation mode can be changed by the IO-Link communications.
 *2. The timer function can be set up using the IO-Link communications for control output 1 and 2 separately. (It is able to select ON delay, OFF delay, or one-shot function and select a timer time of 1 to 4000 ms (T).)
 *3. In the IO-Link mode, if the ON/OFF speed of the sensor is slow, high-speed response of 1 ms or less can be realized using control output 2 as a sensor.
 *4. The judgment time for the instability detection diagnosis can be selected using the IO-Link communications. (For the ON delay timer function to detect instability, the setting can be selected from 0 (invalid), 10, 50, 100, 300, 500, or 1000 ms.
 *5. The judgment condition for the light receiving/non-light receiving instability detection function can be selected using the IO-Link communications. (Setting of light receiving instability detection threshold: 500%/400%/300%/200%/140%, setting of non-light receiving instability detection threshold: 70%/50%)

Function	Sensing object	Present	Not present
ON-delay	L ON	ON 1	OFF 0
	D ON	ON 1	OFF 0
OFF-delay	L ON	ON 1	OFF 0
	D ON	ON 1	OFF 0
One shot	L ON	ON 1	OFF 0
	D ON	ON 1	OFF 0

Reflective / Receiver of Through-beam Model
E3Z-□8□-IL□

When using as a general sensor

When using the Sensor connected to IO-Link Master Unit

Connector Pin Arrangement

M8 Connector
 E3Z-□86-IL□
 E3Z-□87-IL□
 E3Z-T86-D-IL□

Emitter of Through-beam Model
E3Z-T8□-L-IL□

When using as a general sensor

When using the Sensor connected to IO-Link Master Unit

Connector Pin Arrangement

M8 Connector
 E3Z-T86-L-IL□

Note: Pins 2 is not used.

Plugs (Sensor I/O Connectors)

M8 Connector

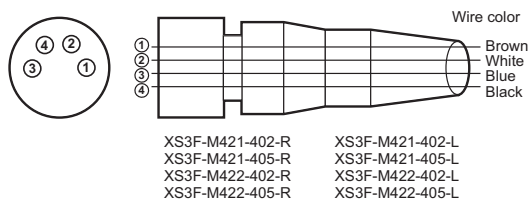

Through-beam Models (Emitter)

Pin arrangement

Classification	Wire color	Connector pin No.	Application
DC	Brown	1	Power supply (+V)
	White	2	-
	Blue	3	Power supply (0 V)
	Black	4	Output C/Q

Note: Pins 2 is not used.

Through-beam Models (Receiver)

Retro-reflective Models

Diffuse-reflective Models

Pin arrangement

Classification	Wire color	Connector pin No.	Application
DC	Brown	1	Power supply (+V)
	White	2	Output DO
	Blue	3	Power supply (0 V)
	Black	4	Output C/Q

Nomenclature

Standard Model

Through-beam

E3Z-T□□(A) (Receiver)

Retro-reflective

E3Z-R□□/E3Z-B□□

Diffuse-reflective

E3Z-D□□

Narrow-beam Reflective

E3Z-L□□

Limited reflective

E3Z-L□□

Laser Model

Through-beam

E3Z-LT□□ (Receiver)

Retro-reflective

E3Z-LR□□

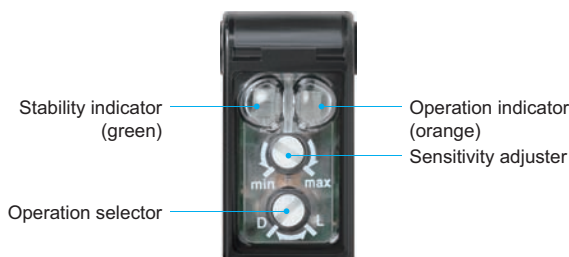

Standard Model

Distance-settable

E3Z-LS□□

Laser Model

Distance-settable

E3Z-LL□□



IO-Link Model

Through-beam

E3Z-T8□-IL□ (Receiver)

Retro-reflective

E3Z-R8□-IL□

Diffuse-reflective

E3Z-D8□-IL□

E3Z-L8□-IL□

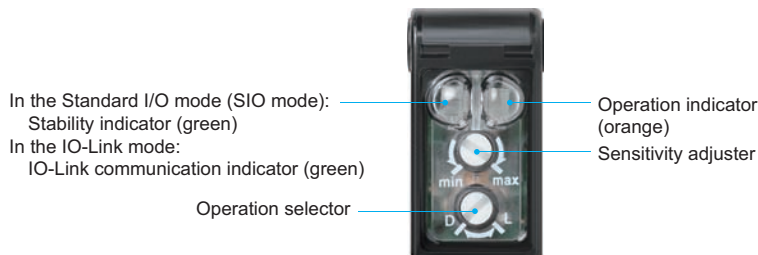



Safety Precautions

Be sure to read the precautions for all models in the website at: <http://www.ia.omron.com/>.

Warning Indications

 WARNING	Warning level Indicates a potentially hazardous situation which, if not avoided, will result in minor or moderate injury, or may result in serious injury or death. Additionally there may be significant property damage.
Precautions for Safe Use	Supplementary comments on what to do or avoid doing, to use the product safely.
Precautions for Correct Use	Supplementary comments on what to do or avoid doing, to prevent failure to operate, malfunction or undesirable effect on product performance.

Meaning of Product Safety Symbols

	General prohibition Indicates the instructions of unspecified prohibited action
	Caution, explosion Indicates the possibility of explosion under specific conditions
	Laser Caution Indicates information related to laser safety

 **WARNING**

This product is not designed or rated for ensuring safety of persons either directly or indirectly. Do not use it for such purposes. 

Do not connect sensor to AC power supply. Risk of explosion. 

Laser Model: E3Z-LT/LR/LL□□-UL

To safely use laser products

 **WARNING**

Looking into the Outgoing light continuously may cause visual impairment. Do not look directly into the Outgoing light.
Caution-Use of controls or adjustments or performance of procedures other than those specified herein may result in hazardous radiation exposure.



Laser safety measures for laser equipment are stipulated by the country of use. Follow the instructions described below categorized in three cases.

1. Application in Japan

According to JIS C6802:2014, the safety measures required of the user are stipulated according to the class of the laser device.

The JIS C6802:2014 standard stipulates the safety precautions that users must take according to the class of the laser product.

This product is classified into class 1 defined by this standard.

2. USA

This product is subjected to the U.S. FDA (Food and Drug Administration) laser regulations.

This product is classified into Class 1 by the IEC 60825-1:2007 standard according to the regulations of Laser Notice No.50 of the FDA standard. This product is already reported to CDRH (Center for Devices and Radiological Health).

Accession Number: 1010248

When using a device equipped with the product in the U.S., attach an FDA certification label near the sensor mounted on customer equipment.

Certification and Identification labels

This laser product complies with 21 CFR 1040.10 and 1040.11 except for deviations pursuant to Laser Notice No.50, dated June 24, 2007
OMRON Corporation
735-5 higashikoji-cho, karasuma-shichijo, shimogyo-ku, Kyoto 660-8216 JAPAN
Place of manufacture:
Shanghai Factory, OMRON Corp.
Manufactured in

3. Regions except the USA

When using in China, GB7247.1: 2012 (IEC60825-1: 2007) applies to this product, it is classified as a Class 1 laser product.

When using in other countries, IEC60825-1:2014/EN60825-1:2014+A11:2021 applies to this product, it is classified as a Class 1 laser product.

Precautions for Safe Use

Be sure to follow the safety precautions below for added safety.

1. Do not use the sensor under the environment with explosive or ignition gas.
2. Never disassemble, repair nor tamper with the product.
3. The maximum power supply voltage is 26.4 VDC (IO-Link Model is 30 VDC). Before turning on the product's power, make sure that the supply voltage does not exceed the maximum power supply voltage.
4. Do not use the sensor over the rated values.
5. Do not use in environments where oil or chemicals may adhere to the cord or sensor body.

Precautions for Correct Use

1. Do not use the product under the following conditions.
 - (1) In the place exposed to the direct sunlight.
 - (2) In the place where humidity is high and condensation may occur.
 - (3) In the place where corrosive gas exists.
 - (4) In the place where vibration or shock is directly transmitted to the product.

2. Connection and Mounting

- (1) There are some cases where the photoelectric sensor cable is unavoidably laid in a tube or duct together with a hightension or power line. This causes an induction, possibly resulting in malfunction or damage. In principal, the cable should be separately laid or shielded.
- (2) For extending wires, use a cable 0.3 mm² min. and 100 m max. in length.

Note: IO-Link Models Use an extension cable with a minimum thickness of 0.3 mm² and less than 100 m long for standard I/O mode, and less than 20 m for IO-Link mode.

- (3) Do not pull the cord too strongly.
- (4) Excessive force (hitting by hammer, etc.) should not be put on the photoelectric sensor because it may damage its water-resistance characteristic. Use M3 screws to mount the photoelectric sensor.
- (5) Tightening torque for the mounting hole is 0.5 N·m or less (M3 screw).

M8 metal connector

- (6) Plug in or out the connector after surly turning off a power supply.
- (7) Plug in or out the connector with a cover part of it.
- (8) Fasten a fixed implement by hand. If you use a plaier, it may be cause of malfunction or damage to it.
- (9) Proper bolting torque is 0.3 to 0.4 N·m to keep water-resistance.

M12 Pre-wired smartclick connector

- (10) Manually tighten the connector.

3. Cleaning

Do not use thinner such as alcohol and benzine because it may melt a surface of a product.

4. Power supply

When using a commercially available switching regulator, be sure to ground the FG (Frame Ground) terminals.

5. Power supply reset time

The photoelectric sensor will begin sensing no later than 100 ms after the power is turned on. If the load and the photoelectric sensor is connected to different power supply, the photoelectric sensor must be always turned on first.

6. Turning off the power supply.

When turning off the power, output pulse may be generated. We recommend turning off the power supply of the load or load line first.

7. Load short circuit protection

This product is provided with function of load short circuit protection. However, be never short-circuited of the load. Please do not throw the current that exceeds ratings into the load. Control output is turned off when this function operates. After checking of wiring and load current, make power supply again. Then the circuit is reset. Load short circuit protection operates when the current is 1.8 times over than the rated load current. The inrush current should be 1.8 times less than the rated load current when L load is used.

8. Water resistance

Though this is type IP67, do not use in the water, rain or outdoors.

9. Do not use the product in ambient atmosphere or environment exceeding the rating.

10.  Dispose in accordance with applicable regulations.



E3Z-□-UL

Dimensions

(Unit: mm)

Tolerance class IT16 applies to dimensions in this data sheet unless otherwise specified.

Sensors

Through-beam* Pre-wired Models

Standard Model E3Z-T61(A)/T62 E3Z-T81(A)/T82

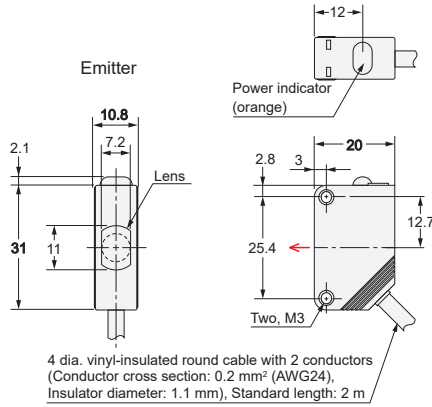

Terminal No.	Specifications
1	+V
2	—
3	0 V
4	—

Note: Pins 2 and 4 are not used.

M12 Pre-wired Smartclick Connector (-M1TJ-UL)

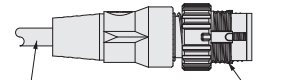

4 dia. vinyl-insulated round cable with 2 or 3 conductors, Standard length: 0.3 m

Note: The Emitter cable has two conductors and the Receiver cable has three conductors.

Laser Model E3Z-LT61/LT81

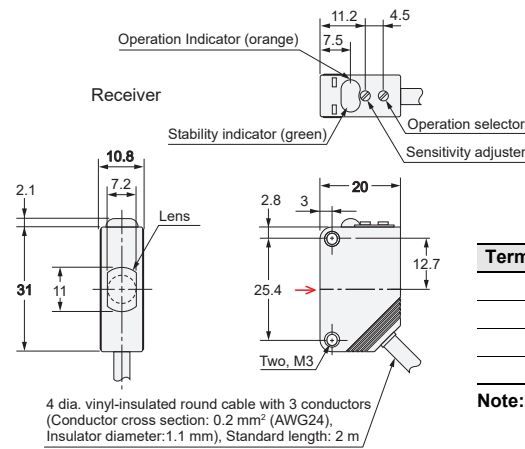

Terminal No.	Specifications
1	+V
2	—
3	0 V
4	Output

Note: Pin 2 is not used.

IO-Link Model E3Z-T81-IL□

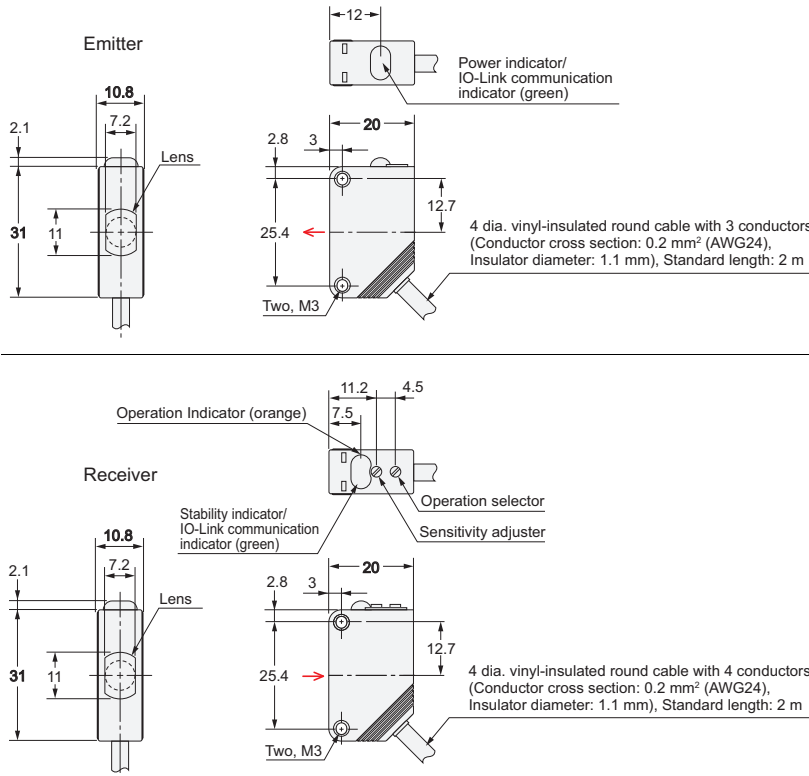

* Models numbers for Through-beam Sensors (E3Z-T□□□) are for sets that include both the Emitter and Receiver. The model number of the Emitter is expressed by adding "-L" to the set model number (example: E3Z-T61-L-UL 2M), the model number of the Receiver, by adding "-D" (example: E3Z-T61-D-UL 2M.) Refer to *Ordering Information* to confirm model numbers for Emitter and Receivers.

Through-beam*
Connector Models

Standard Model
E3Z-T66(A)/T67
E3Z-T86(A)/T87

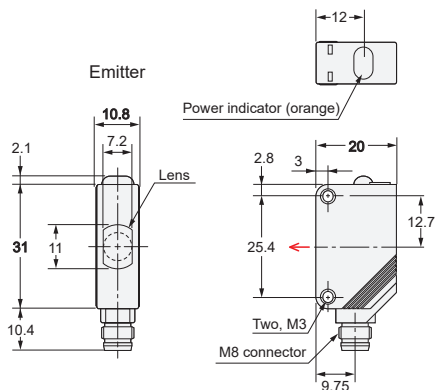

Terminal No.	Specifications
1	+V
2	---
3	0 V
4	---

Note: Pins 2 and 4 are not used.

Laser Model
E3Z-LT66/LT86

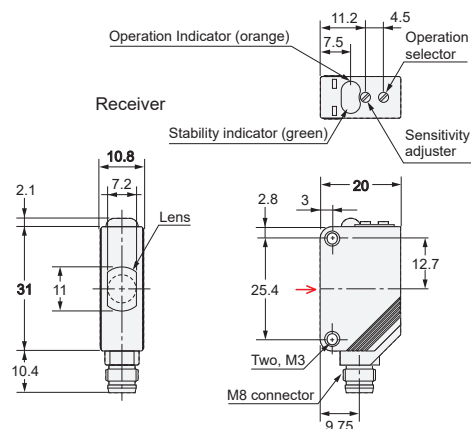

Terminal No.	Specifications
1	+V
2	---
3	0 V
4	Output

Note: Pin 2 is not used.

IO-Link Model
E3Z-T86-IL□

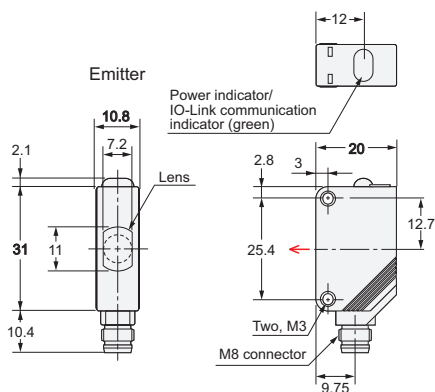

Terminal No.	Specifications
1	+V
2	---
3	0 V
4	Output C/Q

Note: Pins 2 is not used.

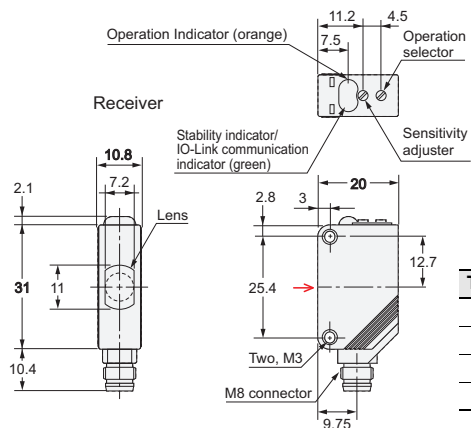

Terminal No.	Specifications
1	+V
2	Output DO
3	0 V
4	Output C/Q

* Models numbers for Through-beam Sensors (E3Z-T□□) are for sets that include both the Emitter and Receiver. The model number of the Emitter is expressed by adding "L" to the set model number (example: E3Z-T66-L-UL 2M), the model number of the Receiver, by adding "-D" (example: E3Z-T66-D-UL 2M.) Refer to *Ordering Information* to confirm model numbers for Emitter and Receivers.

E3Z-□-UL

Retro-reflective / Diffuse-reflective / Limited reflective

Pre-wired Models

Standard Model

E3Z-R61/R81

E3Z-D61/D62/D81/D82

E3Z-L61/L63/L81/L83

E3Z-B61/B62/B81/B82



Laser Model

E3Z-LR61/LR81

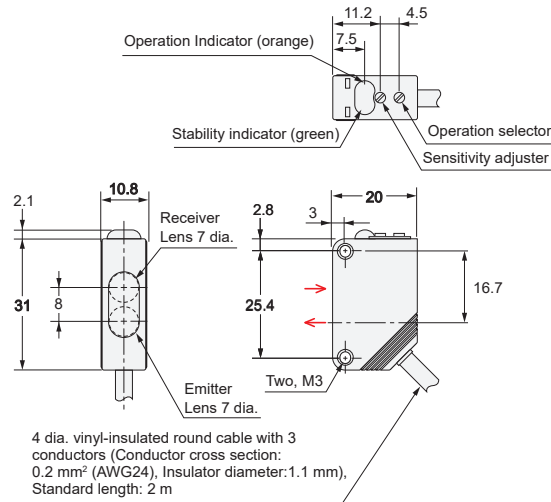

M12 Pre-wired Smartclick Connector (-M1TJ-UL)

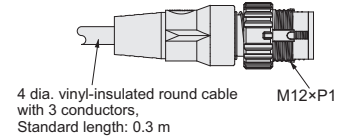

Terminal No.	Specifications
1	+V
2	---
3	0 V
4	Output

Note: The lens for the E3Z-D□2 is black.

IO-Link Model

E3Z-R81-IL□

E3Z-D82-IL□

E3Z-L81-IL□

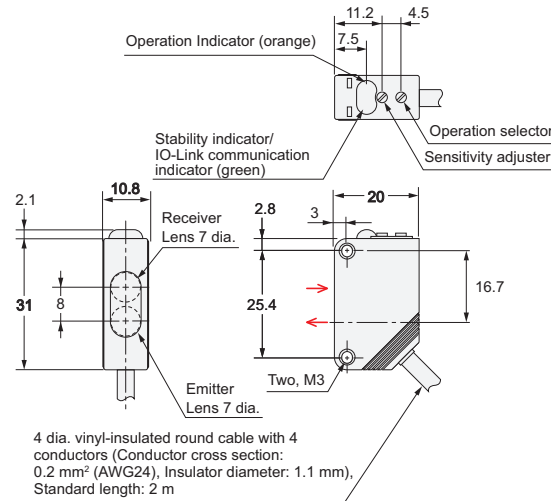

Note: The lens for the E3Z-D82-IL□ is black.

Retro-reflective / Diffuse-reflective / Limited reflective

Connector Models

Standard Model

- E3Z-R66/R86
- E3Z-D66/D67/D86/D87
- E3Z-L66/L68/L86/L88
- E3Z-B66/B67/B86/B87

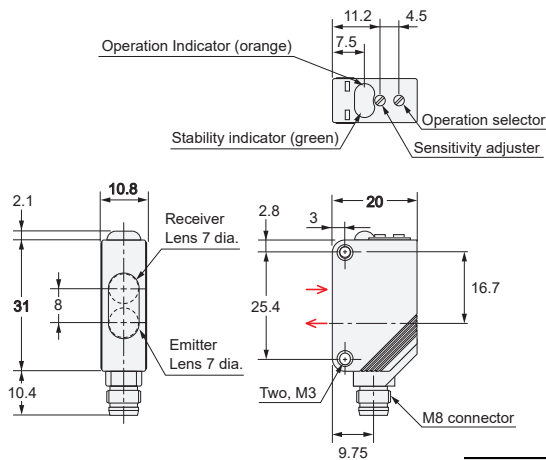

Laser Model

- E3Z-LR66/LR86



Terminal No.	Specifications
1	+V
2	---
3	0 V
4	Output

Note: The lens for the E3Z-D□7 is black.

IO-Link Model

- E3Z-R86-IL□
- E3Z-D87-IL□
- E3Z-L86-IL□

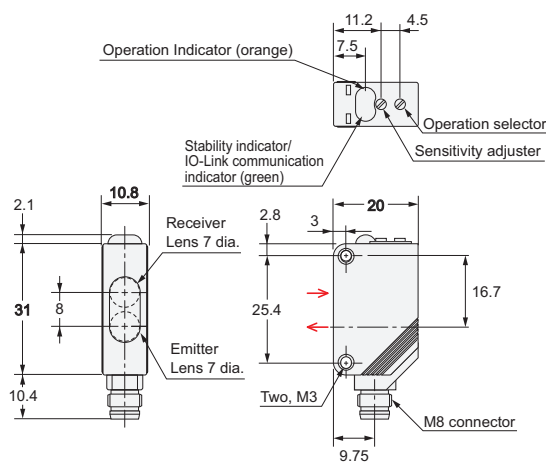

Terminal No.	Specifications
1	+V
2	Output DO
3	0 V
4	Output C/Q

Note: The lens for the E3Z-D87-IL□ is black.

Distance-settable Pre-wired Models

Standard Model
E3Z-LS61/LS63
E3Z-LS81/LS83



Laser Model
E3Z-LL61/LL63
E3Z-LL81/LL83

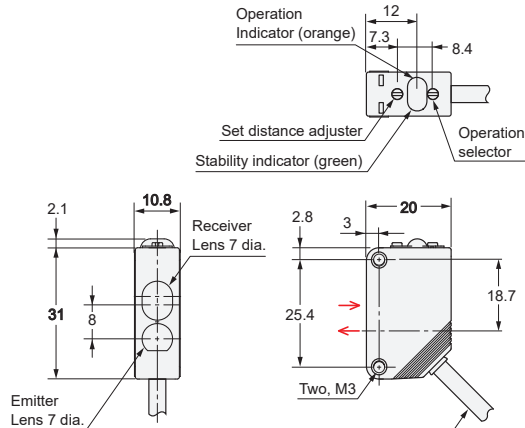

4 dia. vinyl-insulated round cable with
3 or 4 conductors (Conductor cross section:
0.2 mm² (AWG24), Insulator diameter: 1.1 mm),
Standard length: 2 m

Note: Standard Model has four conductors
and Laser Model has three conductors.

Distance-settable Connector Models

Standard Model
E3Z-LS66/LS68
E3Z-LS86/LS88



Laser Model
E3Z-LL66/LL68
E3Z-LL86/LL88

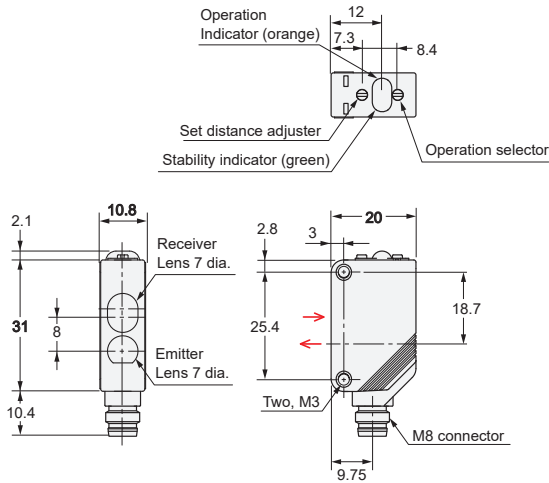

Standard Model

Terminal No.	Specifications
1	+V
2	BGS/FGS switchable
3	0 V
4	Output

Laser Model

Terminal No.	Specifications
1	+V
2	---
3	0 V
4	Output

Note: Terminal 2 is not used.

Accessories (Order Separately)

Slits

E39-S65A
E39-S65B
E39-S65C

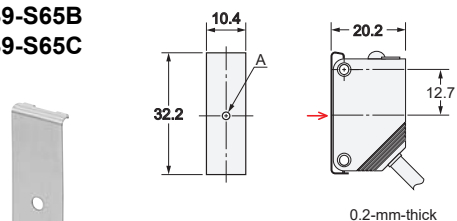

Model	Size A	Material
E39-S65A	0.5 dia.	SUS301 stainless steel
E39-S65B	1.0 dia.	SUS301 stainless steel
E39-S65C	2.0 dia.	SUS301 stainless steel

Slits

E39-S65D
E39-S65E
E39-S65F

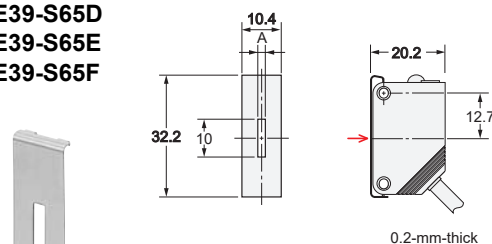

Model	Size A	Material
E39-S65D	0.5	SUS301 stainless steel
E39-S65E	1.0	SUS301 stainless steel
E39-S65F	2.0	SUS301 stainless steel

Mounting Brackets

E39-L44

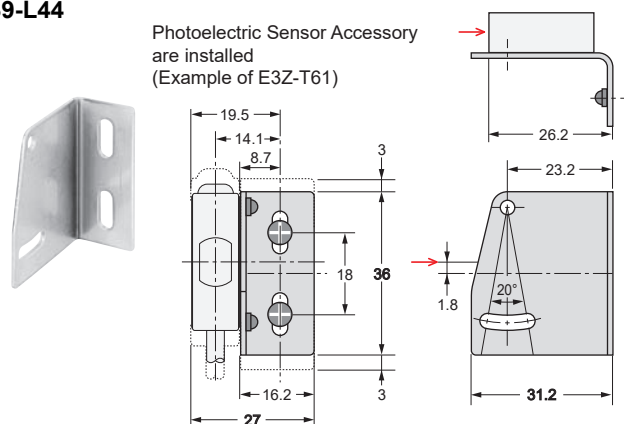

Mounting Brackets

E39-L104

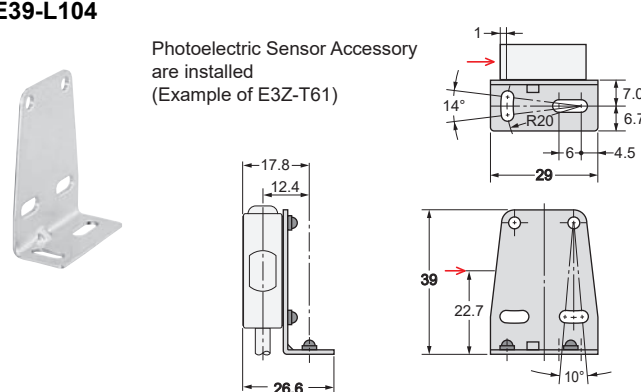

Reflector

E39-R1
E39-R1S

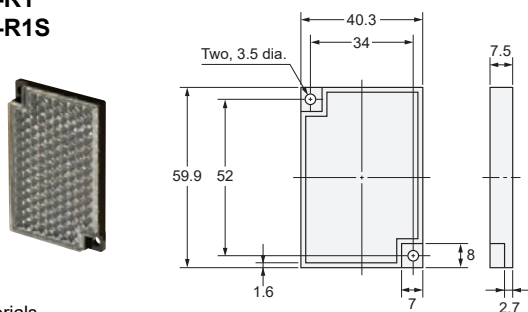

Materials
Reflective surface: Acrylic
Rear surface: ABS

Reflector (For Laser Model)

E39-R6

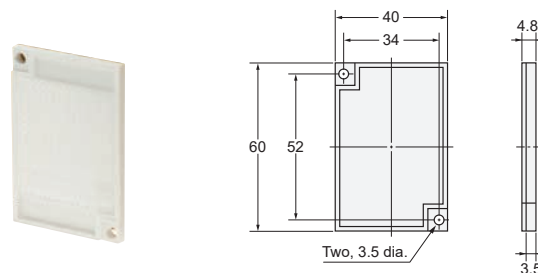

Materials
Reflective surface: Acrylic
Rear surface: ABS

Reflector (For Laser Model)

E39-R12

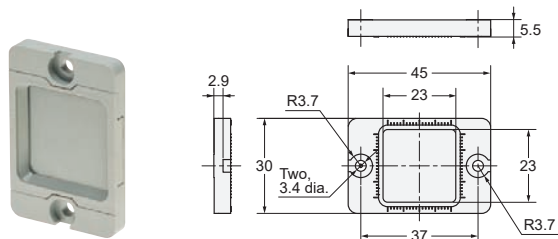

Materials
Reflector: Polycarbonate (surface)
Acrylic (interior)
Frame: ABS

Mounting Brackets, Reflector

For details, refer to on the E39-L/E39-S/E39-R information available on the OMRON website.

Flexible Mounting Bracket

E39-L261

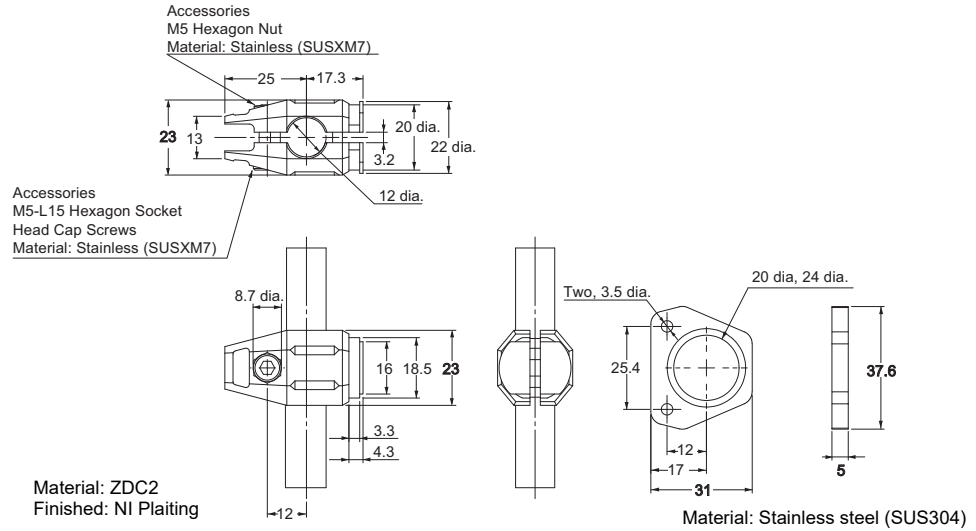

Note: Accessories 2-M3-L10 Cross Recessed Pan Head Screws (Attached to SW+JIS)

Post 50 mm

E39-L262

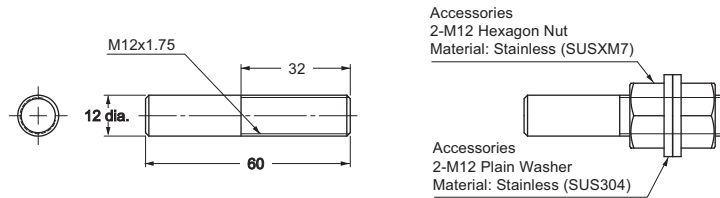

Material: Stainless steel (SUS304)

Post 100 mm

E39-L263

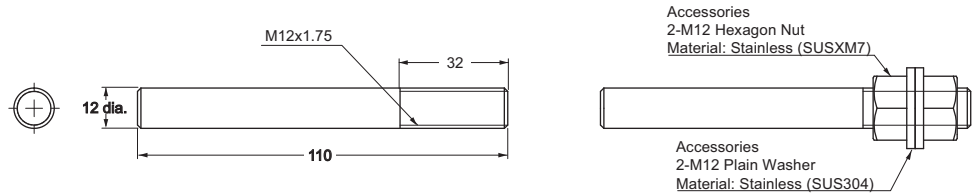

Material: Stainless steel (SUS304)

Air Blow Unit

E39-E16

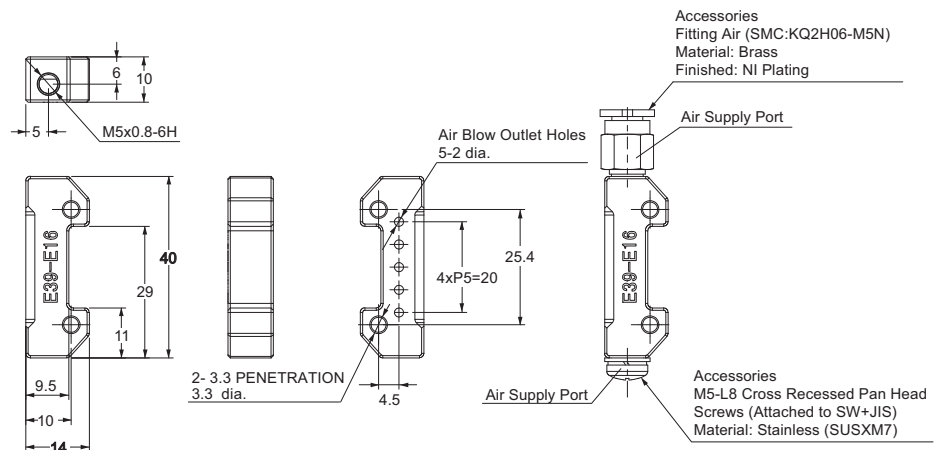

Terms and Conditions Agreement

Read and understand this catalog.

Please read and understand this catalog before purchasing the products. Please consult your OMRON representative if you have any questions or comments.

Warranties.

(a) Exclusive Warranty. Omron's exclusive warranty is that the Products will be free from defects in materials and workmanship for a period of twelve months from the date of sale by Omron (or such other period expressed in writing by Omron). Omron disclaims all other warranties, express or implied.

(b) Limitations. OMRON MAKES NO WARRANTY OR REPRESENTATION, EXPRESS OR IMPLIED, ABOUT NON-INFRINGEMENT, MERCHANTABILITY OR FITNESS FOR A PARTICULAR PURPOSE OF THE PRODUCTS. BUYER ACKNOWLEDGES THAT IT ALONE HAS DETERMINED THAT THE PRODUCTS WILL SUITABLY MEET THE REQUIREMENTS OF THEIR INTENDED USE.

Omron further disclaims all warranties and responsibility of any type for claims or expenses based on infringement by the Products or otherwise of any intellectual property right. (c) Buyer Remedy. Omron's sole obligation hereunder shall be, at Omron's election, to (i) replace (in the form originally shipped with Buyer responsible for labor charges for removal or replacement thereof) the non-complying Product, (ii) repair the non-complying Product, or (iii) repay or credit Buyer an amount equal to the purchase price of the non-complying Product; provided that in no event shall Omron be responsible for warranty, repair, indemnity or any other claims or expenses regarding the Products unless Omron's analysis confirms that the Products were properly handled, stored, installed and maintained and not subject to contamination, abuse, misuse or inappropriate modification. Return of any Products by Buyer must be approved in writing by Omron before shipment. Omron Companies shall not be liable for the suitability or unsuitability or the results from the use of Products in combination with any electrical or electronic components, circuits, system assemblies or any other materials or substances or environments. Any advice, recommendations or information given orally or in writing, are not to be construed as an amendment or addition to the above warranty.

See <http://www.omron.com/global/> or contact your Omron representative for published information.

Limitation on Liability: Etc.

OMRON COMPANIES SHALL NOT BE LIABLE FOR SPECIAL, INDIRECT, INCIDENTAL, OR CONSEQUENTIAL DAMAGES, LOSS OF PROFITS OR PRODUCTION OR COMMERCIAL LOSS IN ANY WAY CONNECTED WITH THE PRODUCTS, WHETHER SUCH CLAIM IS BASED IN CONTRACT, WARRANTY, NEGLIGENCE OR STRICT LIABILITY.

Further, in no event shall liability of Omron Companies exceed the individual price of the Product on which liability is asserted.

Suitability of Use.

Omron Companies shall not be responsible for conformity with any standards, codes or regulations which apply to the combination of the Product in the Buyer's application or use of the Product. At Buyer's request, Omron will provide applicable third party certification documents identifying ratings and limitations of use which apply to the Product. This information by itself is not sufficient for a complete determination of the suitability of the Product in combination with the end product, machine, system, or other application or use. Buyer shall be solely responsible for determining appropriateness of the particular Product with respect to Buyer's application, product or system. Buyer shall take application responsibility in all cases.

NEVER USE THE PRODUCT FOR AN APPLICATION INVOLVING SERIOUS RISK TO LIFE OR PROPERTY OR IN LARGE QUANTITIES WITHOUT ENSURING THAT THE SYSTEM AS A WHOLE HAS BEEN DESIGNED TO ADDRESS THE RISKS, AND THAT THE OMRON PRODUCT(S) IS PROPERLY RATED AND INSTALLED FOR THE INTENDED USE WITHIN THE OVERALL EQUIPMENT OR SYSTEM.

Programmable Products.

Omron Companies shall not be responsible for the user's programming of a programmable Product, or any consequence thereof.

Performance Data.

Data presented in Omron Company websites, catalogs and other materials is provided as a guide for the user in determining suitability and does not constitute a warranty. It may represent the result of Omron's test conditions, and the user must correlate it to actual application requirements. Actual performance is subject to the Omron's Warranty and Limitations of Liability.

Change in Specifications.

Product specifications and accessories may be changed at any time based on improvements and other reasons. It is our practice to change part numbers when published ratings or features are changed, or when significant construction changes are made. However, some specifications of the Product may be changed without any notice. When in doubt, special part numbers may be assigned to fix or establish key specifications for your application. Please consult with your Omron's representative at any time to confirm actual specifications of purchased Product.

Errors and Omissions.

Information presented by Omron Companies has been checked and is believed to be accurate; however, no responsibility is assumed for clerical, typographical or proofreading errors or omissions.