

# Autonomous Mobile Robots

# LD Series

Designed to automate material transport tasks in factories and indoor facilities.

- Natural-feature navigation:  
Automatically plans efficient routes and prevents collisions
- Fleet management:  
Supervises and coordinates the entire fleet of up to 100 vehicles
- Easy deployment:  
Short installation time, no facility modifications



## Ordering Information

Product Name	Maximum Load	Docking Station Kit *1	Top Plate	Pendant (Joystick)	Ordering Code
LD-60	60 kg		No		37032-00000
		Yes		No	37032-00002
			Yes		37032-10004
LD-60 ESD *2			No		37032-20000
		Yes		No	37032-20002
			Yes		37032-20004
LD-90	90 kg		No		37042-00000
		Yes		No	37042-00002
			Yes		37042-10004
LD-90 ESD *2			No		37042-20000
		Yes		No	37042-20002
			Yes		37042-20004
LD-90x *3			No		37062-00000
		Yes		No	37062-00002
			Yes		37062-10004
LD-90x ESD *2 *3			No		37062-20000
		Yes		No	37062-20002
			Yes		37062-20004
LD-250	250 kg		No		37222-00000
		Yes		No	37222-00002
			Yes		37222-10004
LD-250 ESD *2			No		37222-20000
		Yes		No	37222-20002
			Yes		37222-20004

\*1. Includes Battery Power Cable.

\*2. For use in electrostatic-sensitive environments, compliant to the IEC 61340-5-1 standard.

\*3. For use in cart transporter applications.

**Note:** 1. All AMRs in a fleet must have the same version of the FLOW Core software installed. Other considerations must be made when adding AMRs to a fleet. Contact your local OMRON representative for more information.









2. The battery for the AMR must be ordered separately (ordering code 20452-700). Before ordering lithium-ion batteries, please verify local shipping regulations to ensure compliance with applicable laws and restrictions.





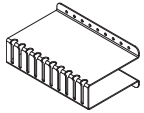

## LD Series

### Items Included With the AMR

Item	Description
Operator Panel Jumper Plug	HDB15 male plug, required when the Operator Panel is removed
Wireless Antennas	Two rubber duck antennas with SMA plugs
Labels	Warning and product labels
USB drive	Contains digital product documentation and software for operating the AMR
Printed Documentation	AMR User's Manual

### Accessories and Optional Items

Item	Details	Ordering Code
	Mobile I/O Box Used with a Fleet Manager to summon an AMR to a goal or control connected devices with I/O Box.	23419-802
	Mobile I/O Box Power Supply Recommended for purchase with the Mobile I/O Box.	23419-812
	High Accuracy Positioning System (HAPS) Single sensor AMR Alignment using magnetic floor tape. Includes single HAPS sensor kit, one mounting bracket, cabling, hardware, and magnetic tape (25 mm wide, 49 m long).	LD-60/90: 13660-100 LD-250: 21374-100
	High Accuracy Positioning System (HAPS) Double sensor AMR Alignment using magnetic floor tape. Includes double HAPS sensor kit, two mounting brackets, cabling, hardware, and magnetic tape (25 mm wide, 49 m long). Requires 24010-000F.	LD-60/90: 13660-000 LD-250: 21374-000
	Magnetic tape 25 mm wide magnetic tape (South top side, 49 m roll)	14925-000
	RS232 Splitter Cable Provides two serial communication connectors (RS232-1 and RS232-2) in an arrangement similar to the legacy AMR Core configuration. Cable length is 200 mm.	24010-000F
	Acuity Localization Camera, mounting kit, cables, leveling kit	13700-000
	Acuity Localization Camera, mounting kit, cables, no leveling kit	13700-100
	Supplementary Laser Scanner Bundle Includes two laser scanners and cabling	13456-000
	Supplementary Laser Scanner Kit Includes two laser scanners, two mounting kits, two metal sensor covers and cabling.	13456-100
	Battery *1 Removable and rechargeable power source for the AMR	20452-700
	Docking Station Used to autonomously charge the battery inside an AMR or to charge an AMR battery outside of the AMR with a battery power cable (sold separately).	12477-000
	Docking Station Extended Wall Mount Kit Includes all mounting washers and screws	14822-100
	Wireless Antenna Extension Kit Includes two dipole antennas, two 2.0 m coaxial cables, and two 0.6 m coaxial cables.	68955-000

Item	Details	Ordering Code
	Battery Power Cable Battery to Docking Station Charging cable, 1.1 m cable length	12676-000L
	Pendant (Joystick) Handheld device for manually driving an AMR and map creation, 3.0 m cable length.	13558-000
	Digital I/O Terminal Block Kit Provides a terminal block for the Digital I/O connector on the Core. Includes a 0.76 m male to female cable, terminal block, and a mounting bracket.	14165-000
	Top Plate - LD-60, LD-90, LD-90x Provides additional protection for the AMR. Includes mounting hardware.	12944-000
	Top Plate - LD-250 Provides additional protection for the AMR. Includes mounting hardware.	20458-002
	Top Plate - LD-250 ESD Provides additional protection for the AMR in ESD environments. Includes mounting hardware.	20458-202
	Rear Facing Laser Bundle Provides CAPS functionality while the AMR is traveling in the reverse direction. Includes TiM laser and required cables.	21446-000

\*1. Before ordering lithium-ion batteries, please verify local shipping regulations to ensure compliance with applicable laws and restrictions.

## Software Licenses

Product Name	Applicable For	Configuration	Ordering Code
<b>Fleet Operations Workspace Core Fleet Manager License, 3 Year</b>	Virtual Fleet Manager	Initial entitlement for a 3 year renewable FLOW Core license. Replace □□ with 05, 10, 15, 20, 25, 30 to indicate the number of AMRs licensed to connect. Replace □□ with 50 for 31 or more AMRs.	30271-1□□ *1
<b>Fleet Operations Workspace Core Fleet Upgrade</b>		Entitlement for fleet connection, increase by one additional AMR (used for existing installations).	30271-001
<b>Fleet Operations Workspace Core Renewal</b>		Entitlement for a 1 year renewal of the FLOW Core license. Replace □□ with a value of 05 to 30, to indicate the number of AMRs licensed to connect. Replace □□ with 50 for 31 or more AMRs.	30271-2□□
<b>Unified Fleet License</b>		Provides interoperability within complex and diverse fleets. Includes Traffic Light Sector to allow for secure, reliable intersection and area exclusion management among multi-vendor AMRs. Entitlement for a perpetual Unified Fleet license.	30271-601
<b>Fleet Operations Workspace iQ License</b>		Entitlement for a 1 year renewable FLOW iQ license.	30271-701
		Entitlement for a 3 year renewable FLOW iQ license.	30271-703
<b>Cell Alignment Positioning System (CAPS) License</b>	AMR	AMR Alignment using software-defined target. Entitlement for a perpetual CAPS license.	20271-805
<b>Cycle Time Optimization License</b>		Enables reduced cycle times with fewer stops and path caching. Entitlement is for a perpetual Cycle Time Optimization license.	20271-905

\*1. After expiration of a FLOW Core Fleet Manager license, all Virtual Fleet Manager functionality will continue to operate without requiring subscription renewals. An active subscription will still be required to access subsequent software releases, including bug fixes, feature upgrades, and performance improvements.

**Note:** To upgrade to the latest version of the FLOW Core software, contact your local OMRON representative. Please note that an active subscription is required for access to software upgrades.

# LD Series

## Features and Components

LD-60, LD-90, LD-90x, LD-60 ESD, LD-90 ESD, and LD-90x ESD

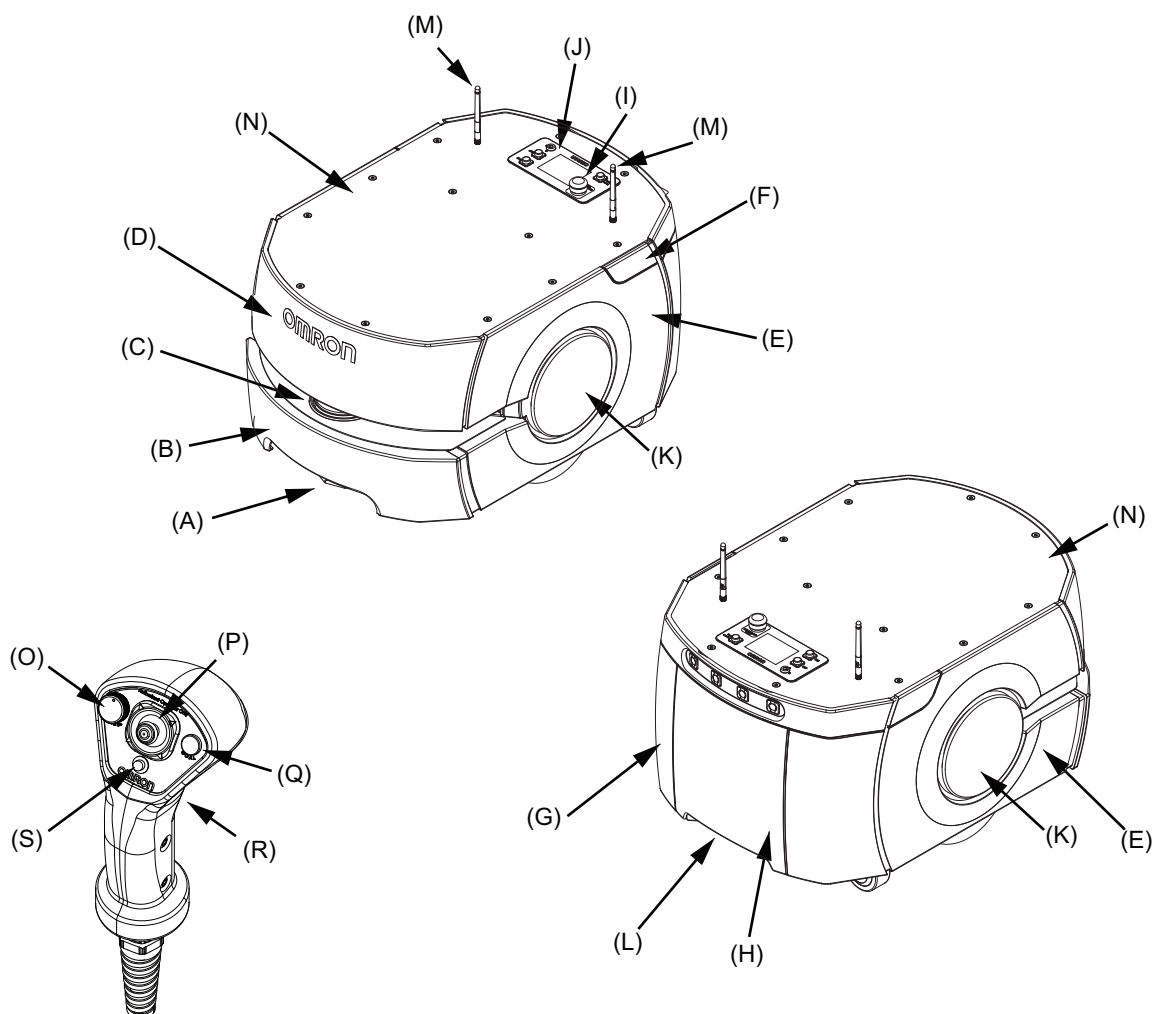

Item	Description	Item	Description
A	Low Laser	K	Light Disk
B	Bumper Skin	L	Charging Contacts
C	Safety Laser Scanner	M	Wireless Antennas
D	Upper Front Skin	N	Payload Mounting Surface (Top Plate shown)
E	Side Skin	O	Speed Control
F	Access Panel	P	Directional Control Stick
G	Rear Skin	Q	Goal Button
H	Battery Door Skin	R	Trigger
I	E-STOP button	S	Indicator Light
J	Operator Panel		

LD-250, LD-250 ESD

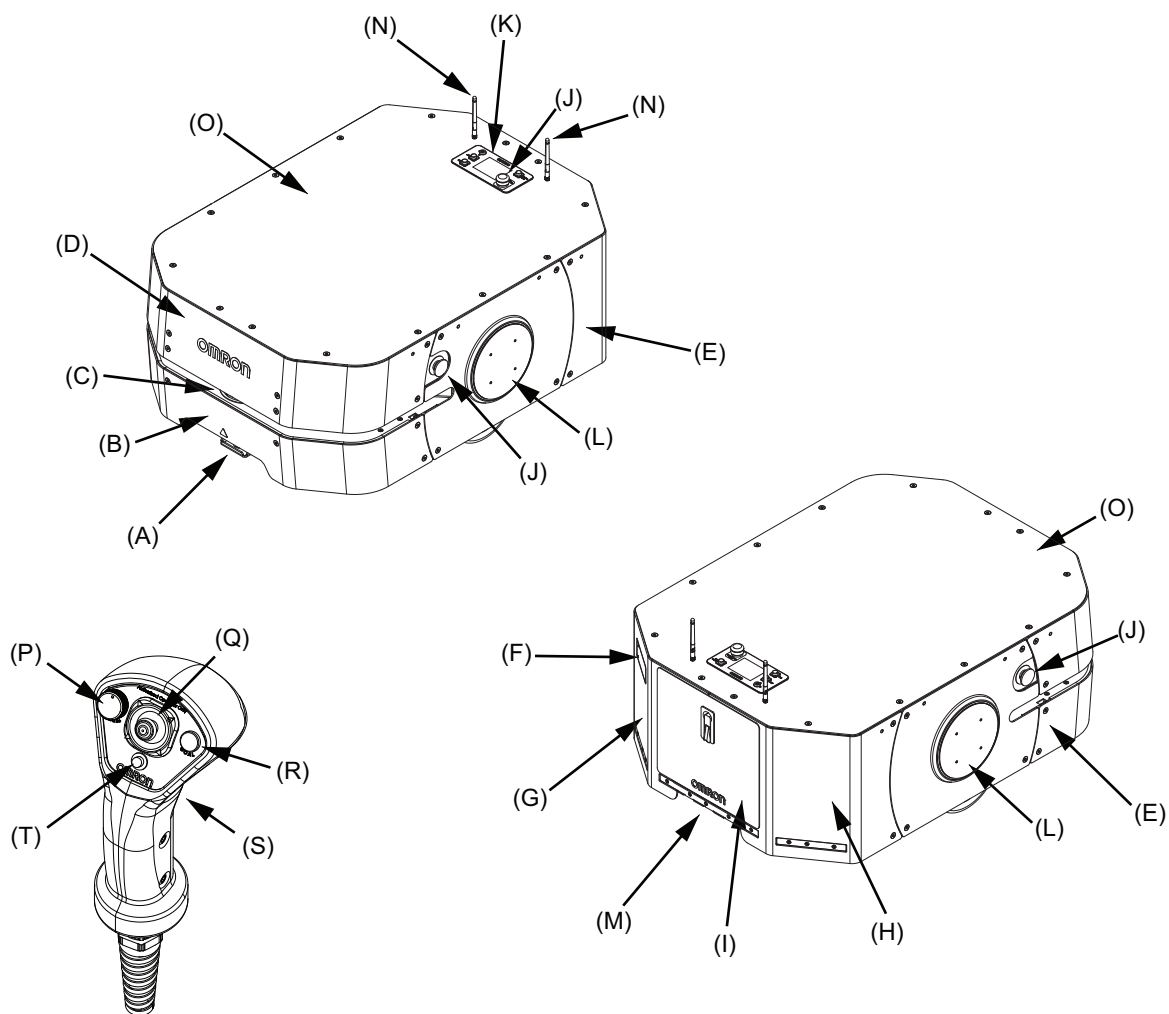

Item	Description	Item	Description
A	Low Laser	K	Operator Panel
B	Bumper Skin	L	Light Disk
C	Safety Laser Scanner	M	Charging Contacts
D	Upper Front Skin	N	Wireless Antennas
E	Side Skin	O	Payload Mounting Surface (Top Plate shown)
F	Access Panel	P	Speed Control
G	Left Rear Skin	Q	Directional Control Stick
H	Right Rear Skin	R	Goal Button
I	Battery Door Skin	S	Trigger
J	E-STOP button	T	Indicator Light

# LD Series

## Specifications

### LD-60, LD-90, LD-90x, LD-60 ESD, LD-90 ESD, and LD-90x ESD

Item		LD-60	LD-90	LD-90x
<b>Weight (with Battery)</b>		62 kg		
<b>Environment</b>	<b>Ambient Temperature</b>	5 to 40°C		
	<b>Ambient Humidity</b>	5% to 95% (non-condensing)		
	<b>Operating Environment</b>	Indoor usage only, no corrosive gas or liquid. Direct sunlight may cause safety laser false positives.		
	<b>Dust / Smoke</b>	Accumulated dust smaller than 37 µm cannot exceed 10 mL/ m <sup>2</sup> in the operating environment. Avoid operating in areas with smoke.		
	<b>Ingress Protection Class</b>	IP20		
	<b>Altitude</b>	1000 m above mean sea level maximum		
<b>Floor Conditions</b>	<b>Floor Requirements</b>	No water, oil or dirt		
	<b>Minimum Floor Flatness</b>	F <sub>F</sub> 25 (ACI 117 standard)		
	<b>Traversable Step</b>	15 mm max. *1	10 mm max. *1	
	<b>Traversable Gap</b>	15 mm max. *2		
	<b>Maximum Slope</b>	Up to 60 kg: 4.8° / 8.3% incline Over 60 kg: Level floor only		
	<b>Minimum Floor Compressive Strength</b>	2.6 Mpa	3.27 Mpa	
<b>Navigation</b>	<b>Routing</b>	Autonomous routing by localizing with safety scanning laser based on environment mapping		
	<b>Environmental Map Making Method</b>	Scan by walking the AMR through the environment, and upload the scan data to the MobilePlanner software		
	<b>Low Front Laser</b>	One Class 1 laser at front of AMR with a 126° field of view		
	<b>Supplementary Laser Scanners (optional)</b>	Two Class 1 lasers with a 270° field of view on the sides of payload structure, user-mounted		
<b>Visual Indicators</b>		Light discs are located on the sides of the AMR. Additional indicators can be added.		
<b>Payload</b>	<b>Maximum Weight</b>	60 kg	90 kg	
<b>Mobility</b>	<b>Run Time (no payload)</b>	15 h approx.		20 h approx.
	<b>Run Time (full payload)</b>	12 h approx.		15 h approx.
	<b>Maximum Speed</b>	1800 mm/s	1350 mm/s	900 mm/s
	<b>Maximum Rotation Speed</b>	180 °/s		
	<b>Stop Position Repeatability (single AMR) *3</b>	<ul style="list-style-type: none"> <li>· To a position: ±65 mm</li> <li>· To standard target: ±25 mm, ±2°</li> <li>· With CAPS: ±8 mm, ±0.5°</li> <li>· With HAPS: ±8 mm, ±0.4°</li> </ul>		
	<b>Stop Position Repeatability (Fleet) *3</b>	<ul style="list-style-type: none"> <li>· To a position: ±85 mm</li> <li>· To standard target: ±35 mm, ±2°</li> <li>· With CAPS: ±12 mm, ±0.5°</li> <li>· With HAPS: ±10 mm, ±0.5°</li> </ul>		
<b>Drive Wheels</b>	<b>Materials</b>	Solid aluminum with non-marking, non-conductive, foam-filled rubber tread		
<b>Passive Casters</b>	<b>Materials</b>	Conductive thermoplastic rubber on polyolefin		
<b>Auxiliary Power</b>		5 VDC±5%, 1 A switched Aux power 12 VDC±5%, 1 A switched Aux power 20 VDC±5%, 1 A switched Aux power 22 to 30 VDC (25.6 VDC nominal), 4 A switched 22 to 30 VDC (25.6 VDC nominal), 10 A switched 22 to 30 VDC (25.6 VDC nominal), 10 A safe, switched 10 A switched and 10 A safe switched are from the same source and pass through the same 10 A fuse, so the sum of their current must be less than 10 A.		
<b>Standards</b>	<b>AMR</b>	UL3100, EN ISO 12100, EN ISO 13849-1, EN 60204-1, ANSI B56.5, EN 61000-6-2, EN 61000-6-4, EN ISO 3691-4 (except: clauses 4.1.15b, 4.8.2.6 for items 6 and 7, 4.12, 4.14), KN 61000-6-2, KN 61000-6-4		
	<b>Battery</b>	UN 38.3, ANSI/CAN/UL/ULC 2271		
	<b>Docking Station</b>	UL1012, CSA C22.2.107.2		
	<b>Wireless</b>	IEEE 802.11 a/b/g		
	<b>Cleanroom Rating</b>	ISO 5 / Class 100 (AMR, Battery and Docking Station)		
<b>Certification Marking</b>	<b>AMR</b>	cULus		
	<b>Docking Station</b>	cULus		
	<b>Battery</b>	cRUus		

Item		LD-60	LD-90	LD-90x
Safety Features	Safety Scanning Laser	One at front of AMR Class 1 PLd safety per ISO13849-1 240° field of view		
	E-STOP Buttons	One on Operator Panel, additional E-STOP buttons can be added to the payload structure		
	Rear Sonar	Two at rear of AMR, 2.0 m range. Each pair includes one emitter and one receiver working together.		
	Front Bumper	Two pairs of sensors at the front of the AMR		
Operator Interface	Audible Indicators	Two speakers are included. Additional buzzers can be added.		
	Display	8.89 cm diagonal TFT, 320 x 240 pixels, color screen		
User Interface	Button	ON button, OFF button, Brake-release button, and keyed mode selection		
	Wireless	802.11 a/b/g		
	Ethernet	One general purpose, shielded, Auto-MDIX Ethernet port.		
	Serial	Two serial communication interfaces		
	Digital I/O	16 inputs, 16 outputs		
	Audio	Digital audio in / out		

\*1. A speed of 250 mm/s is recommended for traversing steps, and routine driving over steps should be avoided. Lower speeds may not traverse the step. Faster or frequent driving over steps will shorten the lifespan of the drivetrain components. All steps should have smooth, rounded profiles.

\*2. AMR maximum speed is recommended for traversing gaps, and routine driving over gaps should be avoided. Lower speeds may not traverse the gap. Faster or frequent driving over gaps will shorten the lifespan of the drivetrain components.

\*3. Stop position repeatability values were obtained using default AMR parameters and a map created by the LD-series AMR.

#### LD-250, LD-250 ESD Specifications

Item		LD-250
Weight (with battery)		148 kg
Environment	Ambient Temperature	5 to 40°C
	Ambient Humidity	5% to 95% (non-condensing)
	Operating Environment	Indoor usage only, no excessive dust, no corrosive gas or liquid. Direct sunlight may cause safety laser false positives.
	Dust / Smoke	Accumulated dust smaller than 37 µm cannot exceed 10 mL / m <sup>2</sup> in the operating environment. Avoid operating in areas with smoke.
	Ingress Protection Class	IP20
	Altitude	1000 m above mean sea level maximum
Floor Conditions	Floor Requirements	No water, oil or dirt
	Minimum Floor Flatness	F <sub>F</sub> 25 (ACI 117 standard)
	Traversable Step	10 mm max. *1
	Traversable Gap	15 mm max. *2
	Maximum Slope	Max. 1.7° / 3% incline
	Minimum Floor Compressive Strength	5 Mpa
Navigation	Routing	Autonomous routing by localizing with safety scanning laser based on environment mapping
	Environmental Map Making Method	Scan by manually driving the AMR through the environment, and upload the scan data to the MobilePlanner for map creation.
	Low Front Laser	One Class 1 laser at front of AMR with a 126° field of view
	Supplementary Laser Scanners (optional)	Two Class 1 lasers with a 270° field of view on the sides of payload structure, user-mounted
Visual Indicators		Light discs are located on the sides of the AMR. Additional indicators can be added.
Payload	Maximum Weight	250 kg
Mobility	Run Time (no payload)	13 h approx.
	Run Time (full payload)	10 h approx.
	Maximum Speed	1200 mm/s
	Maximum Rotation Speed	120 °/s
	Stop Position Repeatability (single AMR) *3	<ul style="list-style-type: none"> <li>· To a position: ±75 mm</li> <li>· To standard target: ±25 mm, ±2°</li> <li>· With CAPS: ±8 mm, ±0.5°</li> <li>· With HAPS: ±8 mm, ±0.4°</li> </ul>
	Stop Position Repeatability (Fleet) *3	<ul style="list-style-type: none"> <li>· To a position: ±100 mm</li> <li>· To standard target: ±35 mm, ±2°</li> <li>· With CAPS: ±14 mm, ±0.6°</li> <li>· With HAPS: ±10 mm, ±0.6°</li> </ul>

# LD Series

Item		LD-250
Drive Wheel	Materials	Aluminum with polyurethane tread
Passive Caster	Materials	Elastomer (Polyurethane)
Auxiliary Power		5 VDC±5%, 1 A switched Aux power 12 VDC±5%, 1 A switched Aux power 20 VDC±5%, 1 A switched Aux power 22 to 30 VDC (25.6 VDC nominal), 4 A switched 22 to 30 VDC (25.6 VDC nominal), 10 A switched 22 to 30 VDC (25.6 VDC nominal), 10 A safe, switched 10 A switched and 10 A safe switched are drawn from the same source, and pass through the same 10 A fuse, so the sum of their current must be less than 10 A.
Standards	AMR	UL3100, EN ISO 12100, EN ISO 13849-1, EN 60204-1, ANSI B56.5, EN 61000-6-2, EN 61000-6-4, EN ISO 3691-4 (except: clauses 4.1.15b, 4.8.2.6 for items 6 and 7, 4.12, 4.14), KN 61000-6-2, KN 61000-6-4
	Battery	UN 38.3, ANSI/CAN/UL/ULC 2271
	Docking Station	UL1012, CSA C22.2.107.2
	Wireless	IEEE 802.11 a/b/g
	Cleanroom Rating	ISO 5 / Class 100 (AMR, Battery and Docking Station)
Certification Marking	AMR	cULus
	Docking Station	cULus
	Battery	cRUus
Safety Features	Safety Scanning Laser	One at front of AMR Class 1 PLd safety per ISO13849-1 240° field of view
	E-STOP Buttons	One at Operator Panel, one on each side. Additional E-STOP buttons can be added to the payload structure
	Rear Sensing	Time of flight (TOF) sensors
	Audible Indicators	Two speakers are included. Additional buzzers can be added
Operator Interface	Display	3.5 inch TFT, 320 x 240 pixels, color screen
	Button	ON button, OFF button, Brake-release button, and keyed mode selection
User Interface	Wireless	802.11 a/b/g
	Ethernet	One general purpose, shielded, Auto-MDIX Ethernet port.
	Serial	Two serial communication interfaces
	Digital I/O	16 inputs, 16 outputs
	Audio	Digital audio in / out

\*1. A speed of 600 mm/s is recommended for traversing steps, and routine driving over steps should be avoided. Lower speeds may not traverse the step. Faster or frequent driving over steps and gaps will shorten the lifespan of the drivetrain components. All steps should have smooth, rounded profiles.

\*2. AMR maximum speed is recommended for traversing gaps, and routine driving over gaps should be avoided. Lower speeds may not traverse the gap. Faster or frequent driving over gaps will shorten the lifespan of the drivetrain components.

\*3. Stop position repeatability values were obtained using default AMR parameters and a map created by the LD-series AMR.

**MobilePlanner Software**

<b>MobilePlanner PC</b>	<b>Operating System</b>	Windows 10 (64-bit version), Windows 11
	<b>CPU</b>	1.5 GHz dual-core CPU recommended
	<b>Main Memory</b>	1.5 GB min. (4 GB min. recommended)
	<b>Hard Disk</b>	At least 400 MB of available space
	<b>Video Memory</b>	256 MB min.
	<b>Display</b>	XGA 1280 x 720, 16 million colors
<b>MobilePlanner, Tablet Edition</b>	<b>Operating System</b>	Android® OS, Version 9 or newer, minimum 2 GB of RAM iOS®, Version 10 or newer
<b>Supported Languages</b>		English, Japanese, German, French, Italian, Korean, Spanish, Polish, Simplified Chinese, Traditional Chinese

**Virtual Fleet Manager Software Minimum Hardware Requirements**

<b>Fleet Size / AMR Count</b>	Small / ≤ 5	Medium ≤ 15	Large ≤ 30	X-Large > 30 *1
<b>Virtual CPU</b>	2 cores		4 cores	
<b>ClocksPEED</b>	4 GHz	8 GHz	12 GHz	16 GHz
<b>Virtual RAM</b>	8 GB	16 GB	24 GB	32 GB
<b>Virtual Disk</b>	512 GB			1 TB
<b>FLOW Software Version</b>	Minimum FLOW Core 4.0			

\*1. Contact your local OMRON representative for fleets larger than 100.

**Note:** The PC/IPC/Server is supplied by the user.

**High Accuracy Positioning System (HAPS)**

<b>Sensor</b>	<b>Depth</b>	30 mm
	<b>Width</b>	160 mm
	<b>Ingress Protection Class</b>	IP64
	<b>Environment</b>	-40 to 85°C
	<b>LEDs</b>	Power, tape present, left marker, right marker
<b>Magnetic Tape</b>	<b>Width</b>	25 mm
	<b>Orientation</b>	South up
<b>Markers (Magnetic Tape)</b>	<b>Width</b>	25 mm
	<b>Length</b>	300 mm min. for 500 mm/s drive speed
	<b>Orientation</b>	North up
	<b>Separation From Tape</b>	15 to 30 mm
<b>Connections</b>	<b>Front Sensor</b>	RS232-1 (/dev/ttyUSB9) on the core
	<b>Rear Sensor</b>	RS232-2 (/dev/ttyUSB10) on the core
	<b>Power, Both Sensors</b>	Aux. power using the included splitter cable

**Battery**

<b>Type</b>	Lithium-Ion (LiFePO4)
<b>Weight</b>	19 kg
<b>Voltage</b>	22 to 30 VDC (25.6 VDC nominal)
<b>Capacity</b>	72 Ah (battery cell nominal)
<b>Recharge Time</b>	2 hrs. 10 min. for 20% to 80% charge
<b>Ingress Protection Class</b>	IP20
<b>Recharge Cycles</b>	Approximately 2000 cycles *1
<b>Charging Method</b>	Automatic or manual

\*1. Approximately 80% of nominal battery capacity will be available after using the battery at 100% depth of discharge at temperatures between 15°C to 35°C.

**Docking Station**

<b>Current</b>	8 A *1
<b>Power</b>	100 to 240 VAC, 50 to 60 Hz
<b>Power Consumption</b>	800 W
<b>Humidity</b>	5% to 95%, non-condensing
<b>Temperature</b>	5 to 40° C
<b>Weight</b>	8.2 kg
<b>Mounting</b>	Wall bracket, directly to floor, or on floor with floor plate
<b>Indicators</b>	Power on: blue Charging: yellow
<b>Connector</b>	For out-of-AMR battery charging

\*1. Circuit breaker built into AC power switch

**Joystick (Pendant)**

<b>Weight</b>	0.55 kg
<b>IP Rating</b>	IP56

**Acuity Camera Specifications**

<b>Field of View</b>	140°
<b>Power Input</b>	12 VDC (±10%) supplied from AMR through power connector
<b>Power Consumption</b>	3.3 W maximum

**Version Information**

The details in this document apply to products operating with the following hardware and software versions.

- LD-60/90/90x: AMR Version M, Core Version B, FLOW Core Software Version 4.1.9
- LD-250: AMR Version Y, Core Version C, FLOW Core Software Version 4.1.9
- Docking Station Hardware Version AK
- Battery Version AF

# LD Series

## Dimensions

(Unit: mm)

LD-60, LD-90, LD-90x, LD-60 ESD, LD-90 ESD and LD-90x ESD, LD-250, LD-250 ESD

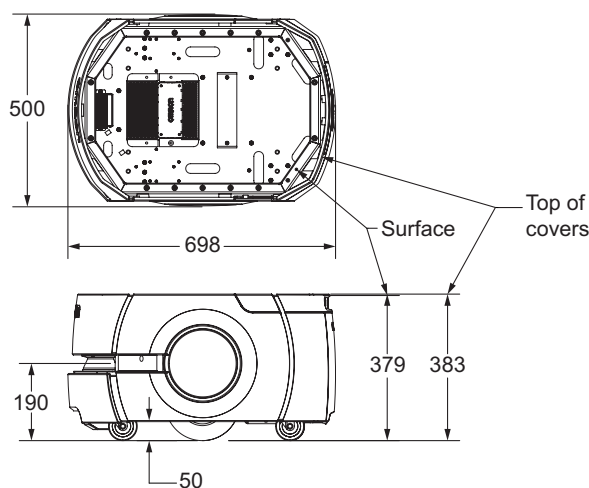

LD-60, LD-90, LD-90x, LD-60 ESD, LD-90 ESD and LD-90x ESD

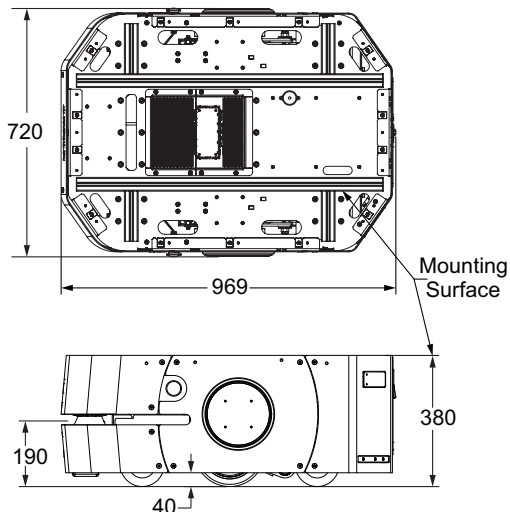

LD-250, LD-250 ESD

### Docking Station

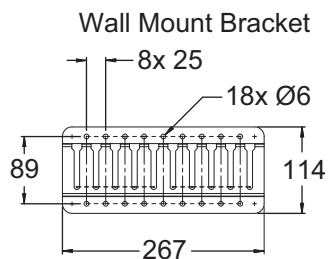
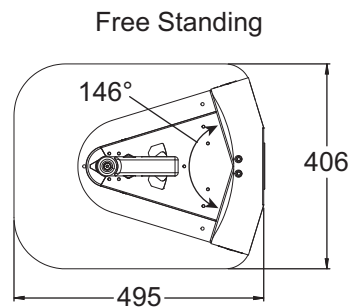
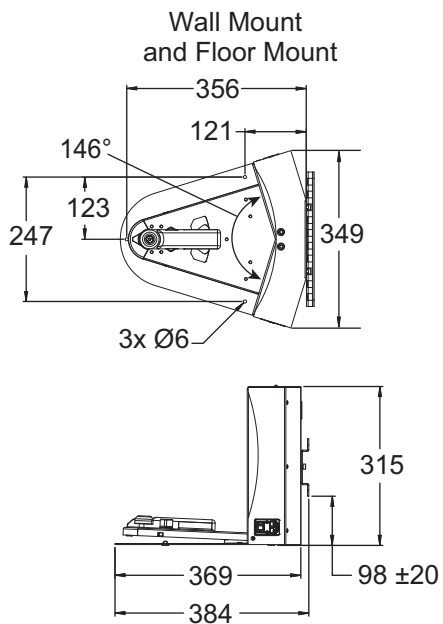

## Related Manuals

Catalog Number	Manual Title
I611	LD-60/90 Platform User's Manual
I616	Mobile Robot LD Safety Guide
I617	Advanced Robotics Command Language Reference Guide
I618	Advanced Robotics Command Language Fleet Manager - Mobile Robots Integration Guide
I635	Fleet Operations Workspace Core User's Manual
I636	Fleet Operations Workspace Core Migration Guide
I637	Fleet Operations Workspace Core Integration Toolkit User Guide
M107	Fleet Operation Workspace Core Integration Toolkit - MQTT API User's Manual
I642	LD-250 Platform User's Manual
I649	Fleet Simulator User's Manual
I665	Fleet Operations Workspace iQ User's Manual
I677	Mobile I/O Box User's Manual
I680	LD-Series Integration Guide
I695	Virtual Fleet Manager Installation Guide

- Intel, Xeon and Intel Xeon are trademarks of Intel Corporation in the U.S. and/or other countries.
- Other company names and product names in this document are the trademarks or registered trademarks of their respective companies.
- The product photographs and figures that are used in this catalog may vary somewhat from the actual products.
- Microsoft product screen shot(s) reprinted with permission from Microsoft Corporation.



# Terms and Conditions Agreement

## **Read and understand this catalog.**

Please read and understand this catalog before purchasing the products. Please consult your OMRON representative if you have any questions or comments.

## **Warranties.**

- (a) Exclusive Warranty. Omron's exclusive warranty is that the Products will be free from defects in materials and workmanship for a period of twelve months from the date of sale by Omron (or such other period expressed in writing by Omron). Omron disclaims all other warranties, express or implied.
- (b) Limitations. OMRON MAKES NO WARRANTY OR REPRESENTATION, EXPRESS OR IMPLIED, ABOUT NON-INFRINGEMENT, MERCHANTABILITY OR FITNESS FOR A PARTICULAR PURPOSE OF THE PRODUCTS. BUYER ACKNOWLEDGES THAT IT ALONE HAS DETERMINED THAT THE PRODUCTS WILL SUITABLY MEET THE REQUIREMENTS OF THEIR INTENDED USE.

Omron further disclaims all warranties and responsibility of any type for claims or expenses based on infringement by the Products or otherwise of any intellectual property right. (c) Buyer Remedy. Omron's sole obligation hereunder shall be, at Omron's election, to (i) replace (in the form originally shipped with Buyer responsible for labor charges for removal or replacement thereof) the non-complying Product, (ii) repair the non-complying Product, or (iii) repay or credit Buyer an amount equal to the purchase price of the non-complying Product; provided that in no event shall Omron be responsible for warranty, repair, indemnity or any other claims or expenses regarding the Products unless Omron's analysis confirms that the Products were properly handled, stored, installed and maintained and not subject to contamination, abuse, misuse or inappropriate modification. Return of any Products by Buyer must be approved in writing by Omron before shipment. Omron Companies shall not be liable for the suitability or unsuitability or the results from the use of Products in combination with any electrical or electronic components, circuits, system assemblies or any other materials or substances or environments. Any advice, recommendations or information given orally or in writing, are not to be construed as an amendment or addition to the above warranty.

See <http://www.omron.com/global/> or contact your Omron representative for published information.

## **Limitation on Liability: Etc.**

OMRON COMPANIES SHALL NOT BE LIABLE FOR SPECIAL, INDIRECT, INCIDENTAL, OR CONSEQUENTIAL DAMAGES, LOSS OF PROFITS OR PRODUCTION OR COMMERCIAL LOSS IN ANY WAY CONNECTED WITH THE PRODUCTS, WHETHER SUCH CLAIM IS BASED IN CONTRACT, WARRANTY, NEGLIGENCE OR STRICT LIABILITY.

Further, in no event shall liability of Omron Companies exceed the individual price of the Product on which liability is asserted.

## **Suitability of Use.**

Omron Companies shall not be responsible for conformity with any standards, codes or regulations which apply to the combination of the Product in the Buyer's application or use of the Product. At Buyer's request, Omron will provide applicable third party certification documents identifying ratings and limitations of use which apply to the Product. This information by itself is not sufficient for a complete determination of the suitability of the Product in combination with the end product, machine, system, or other application or use. Buyer shall be solely responsible for determining appropriateness of the particular Product with respect to Buyer's application, product or system. Buyer shall take application responsibility in all cases.

NEVER USE THE PRODUCT FOR AN APPLICATION INVOLVING SERIOUS RISK TO LIFE OR PROPERTY OR IN LARGE QUANTITIES WITHOUT ENSURING THAT THE SYSTEM AS A WHOLE HAS BEEN DESIGNED TO ADDRESS THE RISKS, AND THAT THE OMRON PRODUCT(S) IS PROPERLY RATED AND INSTALLED FOR THE INTENDED USE WITHIN THE OVERALL EQUIPMENT OR SYSTEM.

## **Programmable Products.**

Omron Companies shall not be responsible for the user's programming of a programmable Product, or any consequence thereof.

## **Performance Data.**

Data presented in Omron Company websites, catalogs and other materials is provided as a guide for the user in determining suitability and does not constitute a warranty. It may represent the result of Omron's test conditions, and the user must correlate it to actual application requirements. Actual performance is subject to the Omron's Warranty and Limitations of Liability.

## **Change in Specifications.**

Product specifications and accessories may be changed at any time based on improvements and other reasons. It is our practice to change part numbers when published ratings or features are changed, or when significant construction changes are made. However, some specifications of the Product may be changed without any notice. When in doubt, special part numbers may be assigned to fix or establish key specifications for your application. Please consult with your Omron's representative at any time to confirm actual specifications of purchased Product.

## **Errors and Omissions.**

Information presented by Omron Companies has been checked and is believed to be accurate; however, no responsibility is assumed for clerical, typographical or proofreading errors or omissions.

**Note: Do not use this document to operate the Unit.**

**OMRON Corporation Industrial Automation Company**

**Kyoto, JAPAN**

**Contact : [www.ia.omron.com](http://www.ia.omron.com)**

**Regional Headquarters**

**OMRON EUROPE B.V.**

Wegalaan 67-69, 2132 JD Hoofddorp  
The Netherlands  
Tel: (31) 2356-81-300 Fax: (31) 2356-81-388

**OMRON ASIA PACIFIC PTE. LTD.**

438B Alexandra Road, #08-01/02 Alexandra  
Technopark, Singapore 119968  
Tel: (65) 6835-3011 Fax: (65) 6835-3011

**OMRON ELECTRONICS LLC**

2895 Greenspoint Parkway, Suite 200  
Hoffman Estates, IL 60169 U.S.A.  
Tel: (1) 847-843-7900 Fax: (1) 847-843-7787

**OMRON ROBOTICS AND SAFETY TECHNOLOGIES, INC.**

4225 Hacienda Drive, Pleasanton, CA 94588 U.S.A.  
Tel: (1) 925-245-3400 Fax: (1) 925-960-0590

**OMRON (CHINA) CO., LTD.**

Room 2211, Bank of China Tower, 200 Yin Cheng Zhong Road,  
PuDong New Area, Shanghai, 200120, China  
Tel: (86) 21-6023-0333 Fax: (86) 21-5037-2388

**Authorized Distributor:**

©OMRON Corporation 2017-2026 All Rights Reserved.  
In the interest of product improvement,  
specifications are subject to change without notice.

**CSM\_15\_1**

**Cat. No. I828-E-16** 0426 (0117)