

Simple Wiring of Sensors, Limit Switches and Actuators

- Greatly reduce wiring in combination with the Smartclick XS5. Also improves maintenance efficiency.
- Features Smartclick connections that enable the connectors to be locked by simply inserting them and turning them approximately 1/8 of a turn. A positive click indicates locking.
- Because these support Smartclick connections, attaching and removal of central ports (8-port type) is made easier.
- Higher rated current to enable output applications.
- Use previous M12 screw connectors.

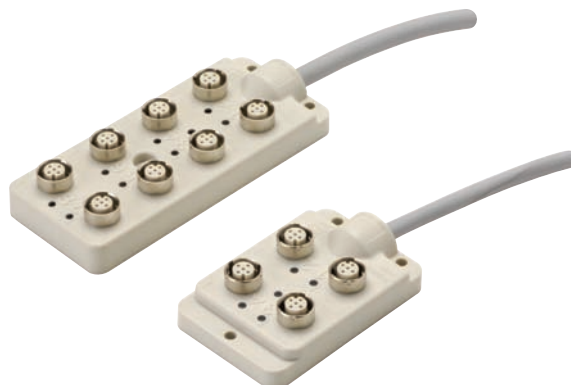

 Refer to *Safety Precautions* on page 8.



Model Number Structure

Model Standards

Use this model number legend to identify products from their model number. When ordering, use a model number from the table in **Ordering Information**.

XW3D- P **5** - **11**

1 2 3 4

1. No. of Ports

P4: 4
P8: 8

2. Connector Poles

No. of connector poles: 5

3. Applicable Sensor Types, No. of I/O (each port)

2: 2-wire DC, No. of I/O (each port) 1
3: 3-wire DC PNP, No. of I/O (each port) 1
5: 3-wire DC NPN, No. of I/O (each port) 1
7: 3-wire DC PNP, No. of I/O (each port) 2
8: 3-wire DC NPN, No. of I/O (each port) 2

4. Cable Length

G: 5 m
H: 7 m
J: 10 m
K: 15 m



Ordering Information

Main Unit

No. of connector poles	Cable specifications	Circuits	Applicable sensor type	No. of connection ports	No. of I/O (each port)	Cable length (m)	Model		
5	Standard cable (PVC)	PNP	3-wire DC	4	1	5	XW3D-P453-G11		
						7	XW3D-P453-H11		
						10	XW3D-P453-J11		
				8	1	5	XW3D-P853-G11		
						7	XW3D-P853-H11		
						10	XW3D-P853-J11		
				4	2	5	XW3D-P457-G11		
						7	XW3D-P457-H11		
						10	XW3D-P457-J11		
		NPN	3-wire DC	4	1	5	XW3D-P455-G11		
						8	XW3D-P855-G11		
						4	2	5	XW3D-P458-G11
		PNP/NPN	2-wire DC	4	1	5	XW3D-P452-G11		
						8	1	5	XW3D-P852-G11

Accessories (Sold Separately)

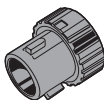
Waterproof Cover

Appearance	Model	Material	Remarks
	XS5Z-11	PBT	The Waterproof Cover ensures IP67. When mounting the Water-resistive Cover to a Connector, be sure to apply a torque range between 0.39 and 0.49 N·m to tighten the Water-resistive Cover. XS5Z-11 is Smartclick mechanism. There's no need to keep track of locking torque.
	XS2Z-22	Brass with Ni plating	

- Note 1. The XW3D comes with a dust cover.
If IP67 degree of protection is required, use the XS5Z-11 or XS2Z-22 (sold separately).
2. The XS2Z-22 connection is threaded.

Ratings and Specifications

Rated current	4 A/port, 12 A/Box (power line)
Rated voltage	10 to 30 VDC
Contact resistance (connector)	40 mΩ max. (20 mV max. and 100 mA max.)
Insulation resistance	100 MΩ min. (at 500 VDC)
Dielectric strength (connector)	500 VAC for 1 min (leakage current: 1 mA max.)
Degree of protection	IP67 (IEC60529)
Insertion tolerance	50 times min.
Lock strength	Pulling: 100 N/15 s, Twisting: 1 N·m/15 s
Cable holding strength	100 N/15 s
Lock operating force	0.1 to 0.25 N·m
Ambient operating temperature range	-25 to 70°C
Ambient humidity range	25% to 85%

Materials and Finish

Item	Model	XW3D
Contacts	Material	Brass
	Finish	Nickel base, 0.4-μm gold plating
Fixtures	Material	Zinc alloy
	Finish	Nickel plated
Case		PBT resin (UL94V-0), light gray
Bushing		Rubber
O-ring		Rubber
PCB		Glass epoxy board
Seal resin		Urethane resin (UL94V-0)
Cable		UL AWM2464 Signal lines: AWG22 Power and ground lines: AWG18

Connection Combinations

OMRON model No.		Smartclick Plug Connectors	M12 Plug Connectors
		XS5H, XS5G, XS5W (plug end), XS5R (plug end)	XS2H, XS2G, XS2W (plug end), XS2R (plug end)
Connector Terminal Box	XW3D	◎	○

◎: Connected by twisting.
○: Connected by screwing.

Pin Arrangement

Item	Poles	5 poles
DC	Female (socket) Contact end	

Note: 4-pole connectors (plugs) can also be connected to the mating connector.

Connections

Table of Applicable Sensor Types and Connections for XW3D Models

Connector Terminal Box	Input device and connector terminal number					
	3-wire PNP 1 +, 3 -, 4 Output	3-wire NPN 1 +, 3 -, 4 Output	2-wire DC (with polarity) 1 +, 4 -	2-wire DC (with polarity) 3 -, 4 +	2-wire DC (without polarity) 3, 4	Limit switch (DC type)
XW3D-P□53-□11/ XW3D-P□57-□11	Available	Not available	Available	Not available	Not available	Not available
XW3D-P□55-□11/ XW3D-P□58-□11	Not available	Available	Not available	Available	Available	Available
XW3D-P□52-G11	Not available	Not available	Available	Not available	Available	Available

Note: Because connector pin No. 2 on the terminal box is empty, connection of NC-type input devices is not possible.

Example Connection Methods

M12 Direct Connection Type

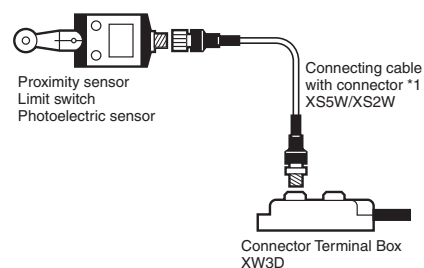

M12 Connector-Terminal Connection Type

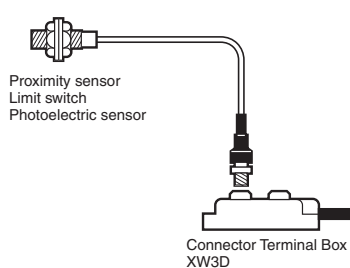

Pre-Wired Type

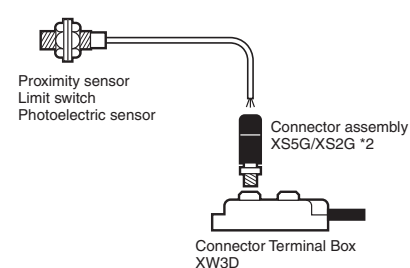

Note: If using an M8 connector type sensor, use XS3W-M42C-4C2-A for the XS3W (M8-M12) conversion cable and switch to an M12 connector.

*1. Connecting cable (straight on both ends) models XS5W-D421-□81-F (Smartclick connection type) and XS2W-D421-□81-F (M12 screw connection type)

□ is where the cable length is entered. C: 1 m, D: 2 m, E: 3 m, G: 5 m, J: 10 m

*2. IDC, crimping, soldering, and screw-on type connector assemblies are available for various types of connections. For details, refer to the data sheet for XS5/XS2.

XW3D and Input Device (Connector Type Sensor/Actuator) Connection Model List

Connector Terminal Box	Applicable sensor/actuator types and connections *1	Applicable sensor/actuator models		
XW3D-P□53-□11/ XW3D-P□57-□11	3-wire DC proximity sensor (PNP) 1 +, 3 -, 4 control output	Direct connection type	Shield type	E2E-X2F1-M1, E2E-X5F1-M1, E2E-X10F1-M1
			Non-shield type	E2E-X5MF1-M1, E2E-X10MF1-M1, E2E-X18MF1-M1
	Photoelectric sensor (PNP) 1 +, 3 -, 4 control output	Connector-terminal connection type *2	Through-beam type	E3Z-T81-M1J 0.3M E3Z-T81-M1TJ 0.3M
			Retro-reflective type	E3Z-R81-M1J 0.3M E3Z-R81-M1TJ 0.3M
			Diffuse-reflective type	E3Z-D82-M1J 0.3M E3Z-D82-M1TJ 0.3M
Actuator wiring 3-4	Solenoid valves, etc.			
XW3D-P□55-□11/ XW3D-P□58-□11	3-wire DC proximity sensor (NPN) 1 +, 3 -, 4 control output	Direct connection type	Shield type	E2E-X2E1-M1, E2E-X5E1-M1, E2E-X10E1-M1
			Non-shield type	E2E-X5ME1-M1, E2E-X10ME1-M1, E2E-X18ME1-M1
	Photoelectric sensor (NPN) 1 +, 3 -, 4 control output	Connector-terminal connection type *2	Through-beam type	E3Z-T61-M1J 0.3M E3Z-T61-M1TJ 0.3M
			Retro-reflective type	E3Z-R61-M1J 0.3M E3Z-R61-M1TJ 0.3M
			Diffuse-reflective type	E3Z-D62-M1J 0.3M E3Z-D62-M1TJ 0.3M
	2-wire DC proximity sensor without polarity 3-4	Connector-terminal connection type	Shield type	E2E-X3D1-M1J-T, E2E-X7D1-M1J-T, E2E-X10D1-M1J-T
	Limit switch (DC type)	Connector-terminal connection type	—	WL□-□DK1EJ-N *3, WL□-□-M1GJ-N *3, D4C-□0□□-DK1EJ□ *4
Direct connection type		WL□-□K13-N *3, D4E-□□10N *4		
Actuator wiring 1-4	Solenoid valves, etc.			
XW3D-P□52-□11	2-wire DC proximity sensor with polarity 1-4	Connector-terminal connection type *2	Shield type	E2E-X2D1-M1TGJ, E2E-X3D1-M1TGJ, E2E-X3D1-M1GJ, E2E-X7D1-M1TGJ, E2E-X7D1-M1GJ, E2E-X10D1-M1TGJ, E2E-X10D1-M1GJ
			Non-shield type	E2E-X8MD1-M1TGJ, E2E-X8MD1-M1GJ, E2E-X14MD1-M1TGJ, E2E-X14MD1-M1GJ, E2E-X20MD1-M1TGJ, E2E-X20MD1-M1GJ
		Direct connection type	Shield type	E2E-X3D1-M1G, E2E-X7D1-M1G, E2E-X10D1-M1G
			Non-shield type	E2E-X8MD1-M1G, E2E-X14MD1-M1G, E2E-X20MD1-M1G
	2-wire DC proximity sensor without polarity 3-4	Connector-terminal connection type	Shield type	E2E-X3D1-M1J-T, E2E-X7D1-M1J-T, E2E-X10D1-M1J-T
	Limit switch (DC type)	Connector-terminal connection type	—	WL□-□DK1EJ-N *3, WL□-□-M1GJ-N *3, D4C-□0□□-DK1EJ□ *4
		Direct connection type		WL□-□K13 *3, D4E-□□10N *4, D4CC-□□□□ *4

Note 1. Use XS5G/XS2G assembly connector models for pre-wired type input devices.

Only main types are shown. Refer to the data sheets for each product for information regarding available proximity sensors and limit switches, as well as detailed specifications.

2. Because connector pin No. 2 on the terminal box is empty, connection of NC-type input devices is not possible.

*1. The numbers shown are the terminal no. of connectors.

*2. Connector-terminal connection type photoelectric sensor E3Z-□-M1TJ 0.3M and proximity sensor E2E-□-M1TGJ have Smartclick connection specifications.

*3. Can only be used when a 1A contact is used.

*4. Only NO connection types can be used. NC types cannot be used.

Wiring Diagram

●Models with One I/O and One Port

PNP Sensor Specifications

3-wire DC PNP,
2-wire DC (with polarity 1-4),
and Actuator (3-4)

NPN Sensor Specifications

3-wire DC NPN,
2-wire DC (with polarity 3-4/without
polarity 3-4), and Actuator (1-4)

2-wire Sensor Specifications

2-wire DC (with polarity 1-4/without
polarity 3-4)

Note: Cannot be used with NPN-type Photoelectric
and Proximity Sensors.
Cannot be used with Proximity Sensors with
polarity 3-4.

XW3D-P□53-□11

3-WIRE
PNP

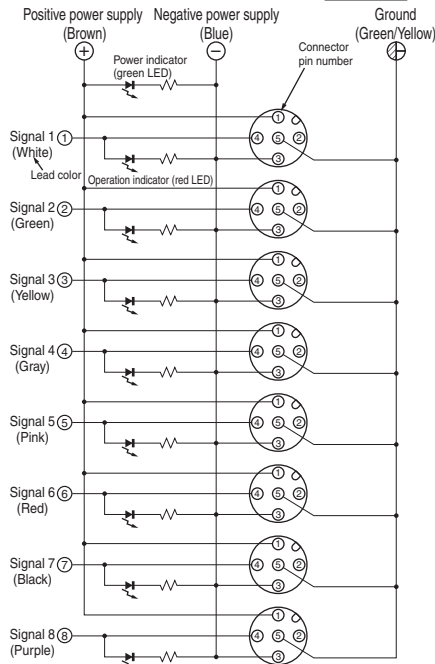

XW3D-P□55-□11

3-WIRE
NPN

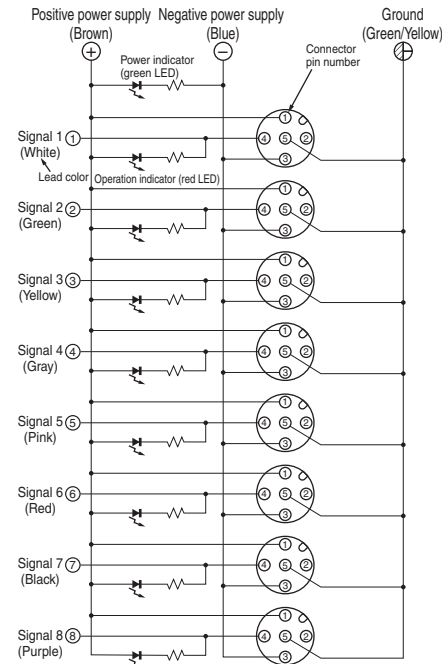

XW3D-P□52-□11

2-WIRE

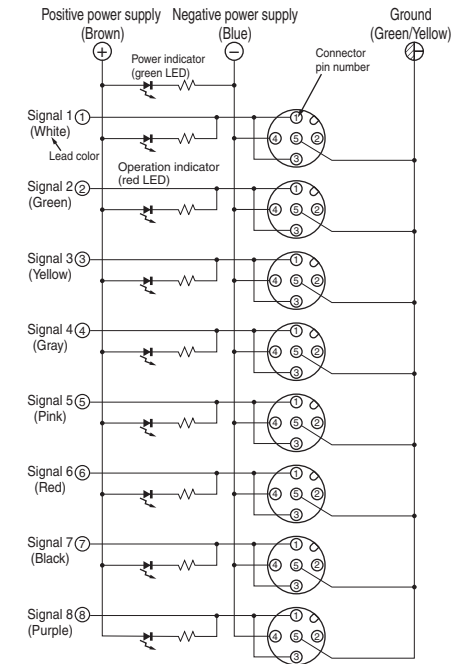

Note 1. The above wiring diagrams are for eight-port use.

2. Figures in parentheses indicate lead colors.

3. The expression "white/red" means white and red stripes.

4. Here, "1-4" and "3-4" represent terminal numbers.

5. Contact numbers 5 through 8 in the above wiring diagrams do not exist on Terminal Boxes with four ports.
The lead colors for signals 1 through 4, power supply, and ground are the same.

●Models with Two I/O and One Port

3-wire DC PNP, Actuator (3-4 or 3-2)

XW3D-P457-□11

3-WIRE
PNP (2)

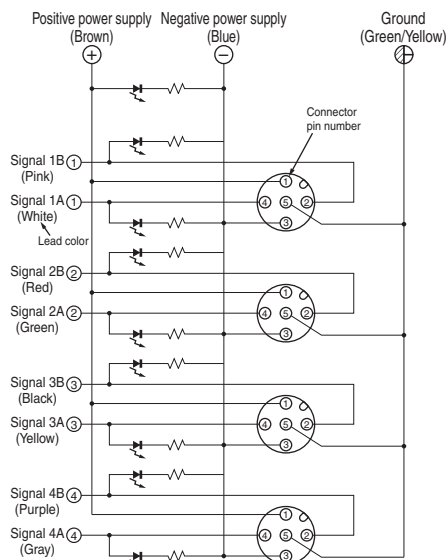

3-wire DC NPN, Actuator (1-4 or 1-2)

XW3D-P458-□11

3-WIRE
NPN (2)

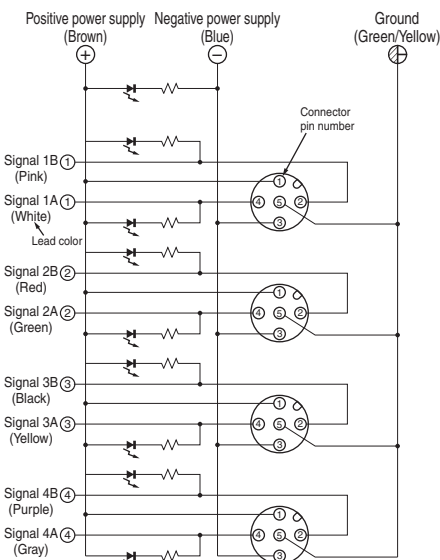

Note: Colors given in the connection diagram are lead colors.

Dimensions

XW3D-P452-□11
 XW3D-P453-□11
 XW3D-P455-□11
 (Model with Four Ports
 and One I/O)

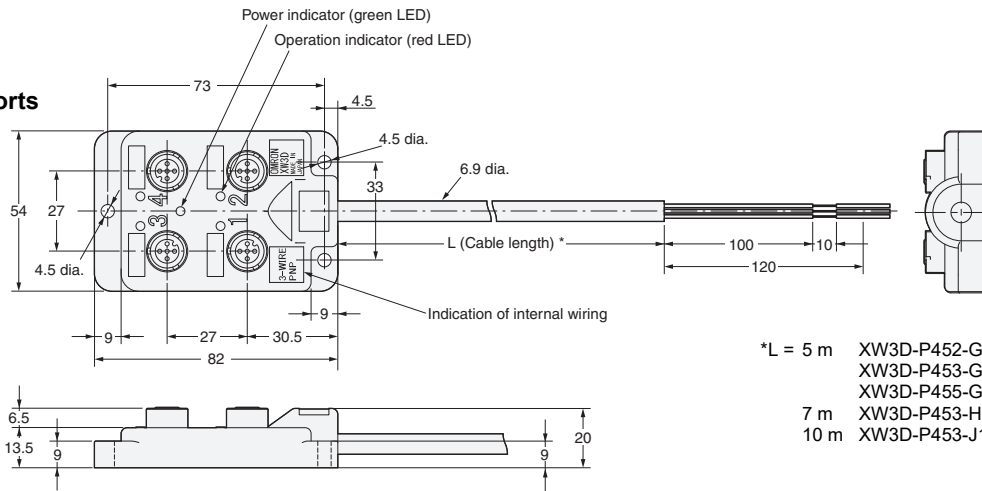

- *L = 5 m XW3D-P452-G11
- XW3D-P453-G11
- XW3D-P455-G11
- 7 m XW3D-P453-H11
- 10 m XW3D-P453-J11

XW3D-P852-□11
 XW3D-P853-□11
 XW3D-P855-□11
 (Model with Eight Ports
 and One I/O)

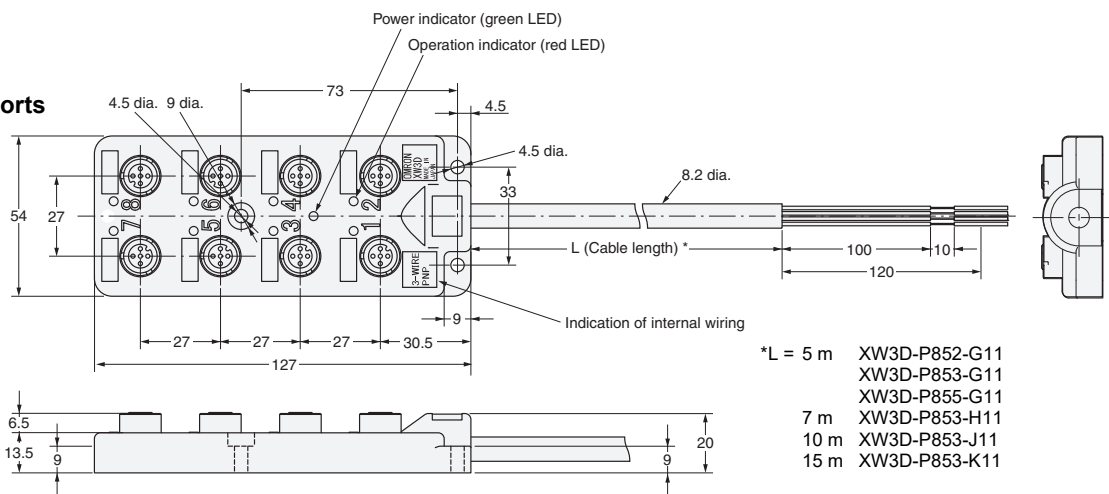

- *L = 5 m XW3D-P852-G11
- XW3D-P853-G11
- XW3D-P855-G11
- 7 m XW3D-P853-H11
- 10 m XW3D-P853-J11
- 15 m XW3D-P853-K11

XW3D-P457-□11
 XW3D-P458-□11
 (Model with Four Ports
 and Two I/O)

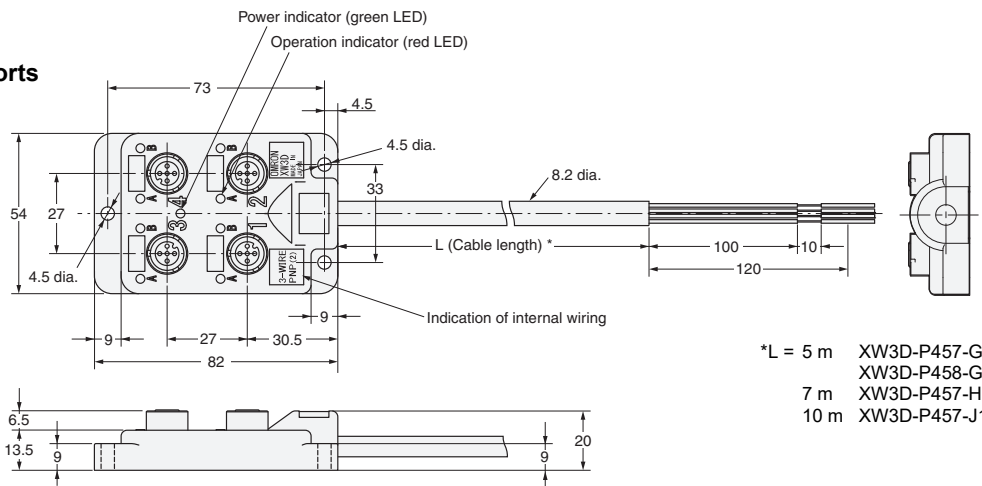

- *L = 5 m XW3D-P457-G11
- XW3D-P458-G11
- 7 m XW3D-P457-H11
- 10 m XW3D-P457-J11

Mounting Dimensions

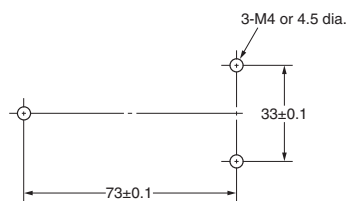

Note: The mounting dimensions are the same regardless of the number of ports.

Safety Precautions

Precautions for Correct Use

Do not use the product in atmospheres or environments that exceed product ratings.

Connector Connection and Disconnection

- Mate the Connectors by following the XS5 connector mating procedure.
- When mating Connectors, be sure to insert the plug all the way to the back of the socket before attempting to lock the Connectors.
- Do not use tools of any sort to mate the Connectors. Always use your hands. Pliers or other tools may damage the Connectors.
- When mating the Connectors to XS2 or other M12 Connectors, tighten the lock by hand to a torque of 0.39 to 0.49 N·m.
- Confirm in the catalog that sensors and actuators are applicable before using them.
- Always turn OFF the power supply before connecting or disconnecting connectors.
- Do not touch the mating surface of the connectors with wet hands.
- Wipe away any water around the connectors.
- Do not allow metal scraps or dust to enter the mating section.

Cable Lead Polarity

- Wire as in the wiring diagram so that the polarities of cable cores (blue: negative power supply, brown: positive power supply) are wired correctly.
- If the polarity is not correct, the load may not operate or the operation indicator may not light.
- Always connect a load to the signal lines to operate a sensor or actuator.

Suitable Connectors

- Always mount a Waterproof Cover (XS2Z-22) or Dust Cover (XS2Z-15) to any unused connector on the Connector Terminal Box.

Power Supply and Operation Indicators

- The power supply indicator will be lit green while power is being supplied. The operation indicator will be lit red while the sensor or actuator is operating.
- The XW3D is for a DC sensor or actuator. Do not use it for an AC sensor or actuator.
- Connector Terminal Boxes are available with either 2-wire or 3-wire internal connections, as indicated on the case.

3-WIRE NPN	2-WIRE	3-WIRE PNP	3-WIRE NPN (2)	3-WIRE PNP (2)
---------------	--------	---------------	-------------------	-------------------

Terms and Conditions Agreement

Read and understand this catalog.

Please read and understand this catalog before purchasing the products. Please consult your OMRON representative if you have any questions or comments.

Warranties.

(a) Exclusive Warranty. Omron's exclusive warranty is that the Products will be free from defects in materials and workmanship for a period of twelve months from the date of sale by Omron (or such other period expressed in writing by Omron). Omron disclaims all other warranties, express or implied.

(b) Limitations. OMRON MAKES NO WARRANTY OR REPRESENTATION, EXPRESS OR IMPLIED, ABOUT NON-INFRINGEMENT, MERCHANTABILITY OR FITNESS FOR A PARTICULAR PURPOSE OF THE PRODUCTS. BUYER ACKNOWLEDGES THAT IT ALONE HAS DETERMINED THAT THE PRODUCTS WILL SUITABLY MEET THE REQUIREMENTS OF THEIR INTENDED USE.

Omron further disclaims all warranties and responsibility of any type for claims or expenses based on infringement by the Products or otherwise of any intellectual property right. (c) Buyer Remedy. Omron's sole obligation hereunder shall be, at Omron's election, to (i) replace (in the form originally shipped with Buyer responsible for labor charges for removal or replacement thereof) the non-complying Product, (ii) repair the non-complying Product, or (iii) repay or credit Buyer an amount equal to the purchase price of the non-complying Product; provided that in no event shall Omron be responsible for warranty, repair, indemnity or any other claims or expenses regarding the Products unless Omron's analysis confirms that the Products were properly handled, stored, installed and maintained and not subject to contamination, abuse, misuse or inappropriate modification. Return of any Products by Buyer must be approved in writing by Omron before shipment. Omron Companies shall not be liable for the suitability or unsuitability or the results from the use of Products in combination with any electrical or electronic components, circuits, system assemblies or any other materials or substances or environments. Any advice, recommendations or information given orally or in writing, are not to be construed as an amendment or addition to the above warranty.

See <http://www.omron.com/global/> or contact your Omron representative for published information.

Limitation on Liability; Etc.

OMRON COMPANIES SHALL NOT BE LIABLE FOR SPECIAL, INDIRECT, INCIDENTAL, OR CONSEQUENTIAL DAMAGES, LOSS OF PROFITS OR PRODUCTION OR COMMERCIAL LOSS IN ANY WAY CONNECTED WITH THE PRODUCTS, WHETHER SUCH CLAIM IS BASED IN CONTRACT, WARRANTY, NEGLIGENCE OR STRICT LIABILITY.

Further, in no event shall liability of Omron Companies exceed the individual price of the Product on which liability is asserted.

Suitability of Use.

Omron Companies shall not be responsible for conformity with any standards, codes or regulations which apply to the combination of the Product in the Buyer's application or use of the Product. At Buyer's request, Omron will provide applicable third party certification documents identifying ratings and limitations of use which apply to the Product. This information by itself is not sufficient for a complete determination of the suitability of the Product in combination with the end product, machine, system, or other application or use. Buyer shall be solely responsible for determining appropriateness of the particular Product with respect to Buyer's application, product or system. Buyer shall take application responsibility in all cases.

NEVER USE THE PRODUCT FOR AN APPLICATION INVOLVING SERIOUS RISK TO LIFE OR PROPERTY OR IN LARGE QUANTITIES WITHOUT ENSURING THAT THE SYSTEM AS A WHOLE HAS BEEN DESIGNED TO ADDRESS THE RISKS, AND THAT THE OMRON PRODUCT(S) IS PROPERLY RATED AND INSTALLED FOR THE INTENDED USE WITHIN THE OVERALL EQUIPMENT OR SYSTEM.

Programmable Products.

Omron Companies shall not be responsible for the user's programming of a programmable Product, or any consequence thereof.

Performance Data.

Data presented in Omron Company websites, catalogs and other materials is provided as a guide for the user in determining suitability and does not constitute a warranty. It may represent the result of Omron's test conditions, and the user must correlate it to actual application requirements. Actual performance is subject to the Omron's Warranty and Limitations of Liability.

Change in Specifications.

Product specifications and accessories may be changed at any time based on improvements and other reasons. It is our practice to change part numbers when published ratings or features are changed, or when significant construction changes are made. However, some specifications of the Product may be changed without any notice. When in doubt, special part numbers may be assigned to fix or establish key specifications for your application. Please consult with your Omron's representative at any time to confirm actual specifications of purchased Product.

Errors and Omissions.

Information presented by Omron Companies has been checked and is believed to be accurate; however, no responsibility is assumed for clerical, typographical or proofreading errors or omissions.