

Introduction

What Is a Cam Positioner?

Traditionally, a mechanical cam and limit switch (or a photoelectric sensor or other sensor) were used to detect rotational angles. A Cam Positioner electrically achieves the function of traditional mechanical cams.

A Cam Positioner reads the angle data from an input detection device (a Resolver or Encoder) and turns an output ON and OFF according to preset ON/OFF angles (called the cam program).

In food packing machines, for example, the Cam Positioner uses angle position data to control the timing of various mechanisms. The purpose of Cam Positioners is generally this type of timing control.

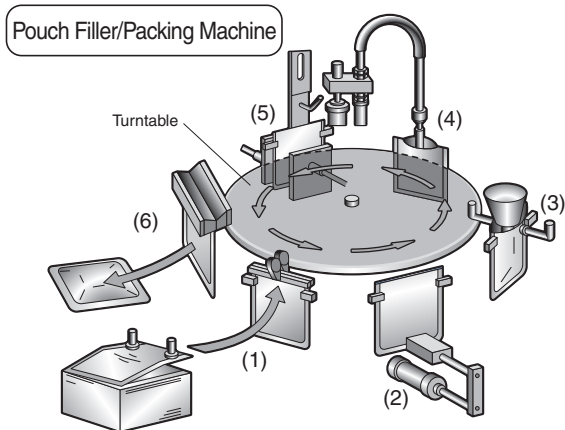

- (1) Control of the arm that supplies pouches from the magazine
- (2) Control of the pump-driven cylinder
- (3) Control of filling pouches with a fixed amount of a solid material
- (4) Control of the plunger and pump used to fill the pouches with a fixed amount of liquid
- (5) Control of pouch sealing and air removal
- (6) Control of the heat-sealing time and discharge arm

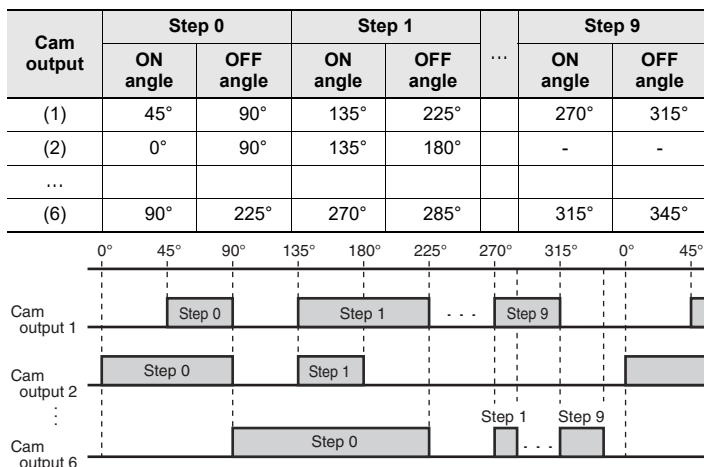

What Is a Resolver?

A Resolver is a type of sensor that detects angles.

Unlike Encoders, Resolvers have a simple structure and have no electronic parts. Their performance is therefore less affected by dust and vibration in comparison with Encoders. This makes them highly reliable and environmentally resistant. Because they are brushless as well, they are maintenance free and their service life depends solely on the ball bearings.



What Is an Absolute Encoder?

An Absolute Encoder is a type of sensor that detects angles. It is a Rotary Encoder that outputs the rotational angle with an absolute code.

The code is read optically or electromagnetically to detect the rotational position.



Sensors

Switches

Safety Components

Relays

Control Components

Automation Systems

Motion / Drives

Energy Conservation Support / Environment Measure Equipment

Power Supplies / In Addition

Others

Common

Description of Operation

This section describes the basic operation of a Cam Positioner. First, a cam program (the ON/OFF pattern for the cam output) is input into the Cam Positioner. Turning the cam output ON and OFF is set up by setting the ON and OFF angles.

The cam program can be selected by setting a bank number with bank switching signals. The Cam Positioner starts operation when the operation signal is turned ON.

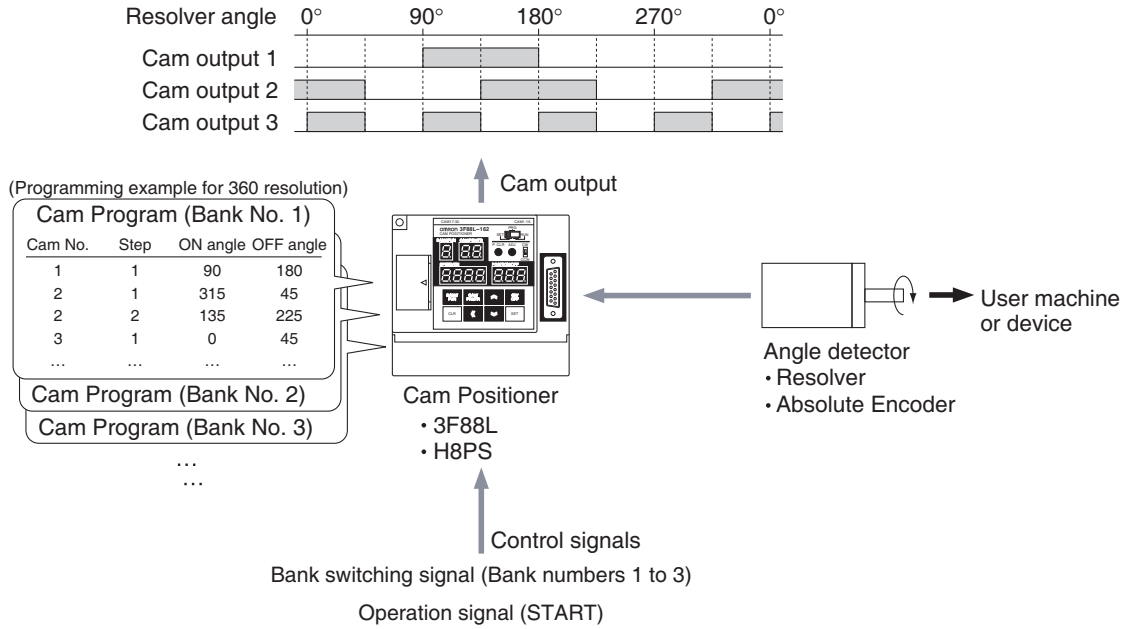

Sensors

Switches

Safety Components

Relays

Control Components

Automation Systems

Motion / Drives

Energy Conservation Support / Environment Measure Equipment

Power Supplies / In Addition

Others

Common

Configuration Example

Using a Resolver to Detect Angles

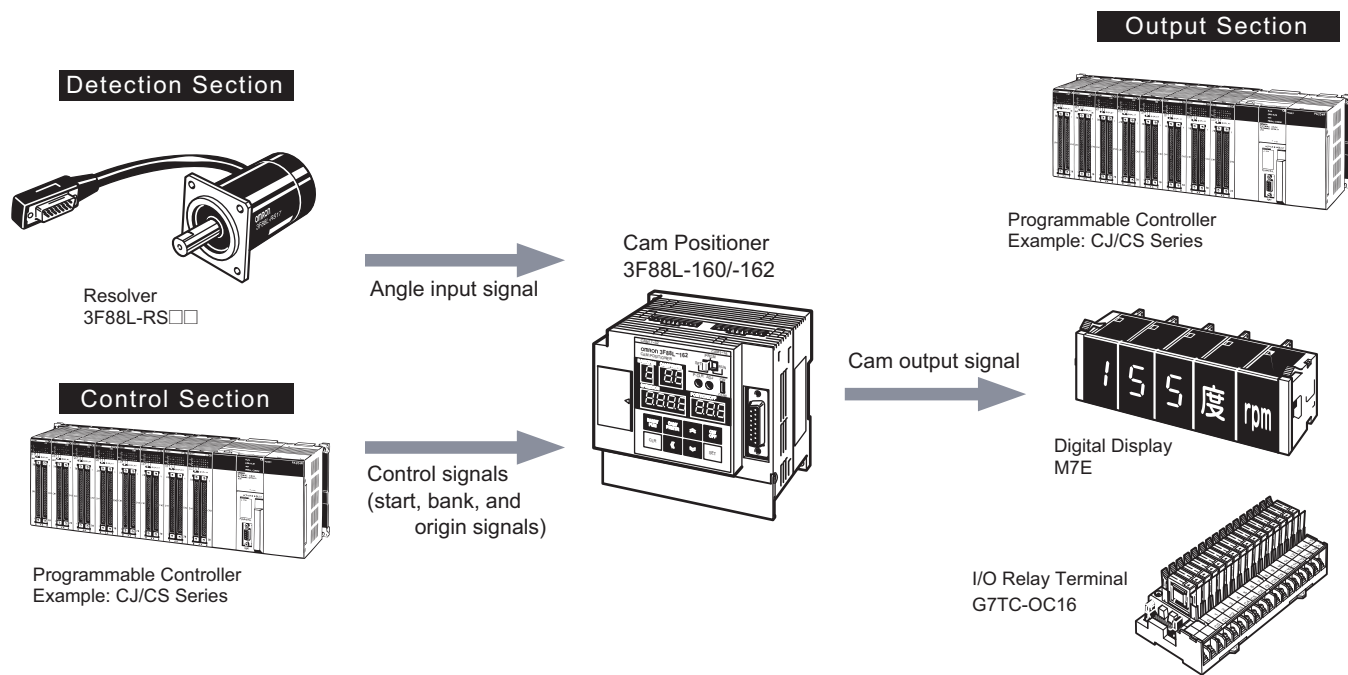

Note: Includes products no longer available to order.

Features

Environmental Resistance

Resolvers have no electronic parts, and therefore have superior environmental resistance in comparison with Encoders, against oil, dust, temperature, and shock. They also have an ambient operating temperature range of -10 to 80°C.

Absolute Angle Detection

Resolvers can detect absolute angles and only one Resolver is needed for high precision at a 360 or 720 resolution.

Shaft-load Tolerance: 196 N, Shaft Diameter: 10 mm (3F88L-RS17/RS17T)

With radial and thrust shaft-load tolerances of 196 N, Resolvers generally outperform other detectors, such as Encoders.

Maximum Cable Length Up to 100 m

Resolver cables can be extended up to 100 m to enable remote operation and control from a location well away from the Resolver.

Operating Principle

As shown in the following diagram, $\sin \theta$ and $\cos \theta$ voltage is applied to the two sets of fixed windings, $S_1 - S_3$ and $S_2 - S_4$, respectively, that are mechanically 90° out of phase. Observing the $\sin(\theta - \alpha)$ voltage induced in the rotating winding $R_1 - R_2$ makes the Resolver a kind of rotating transformer that detects angles.

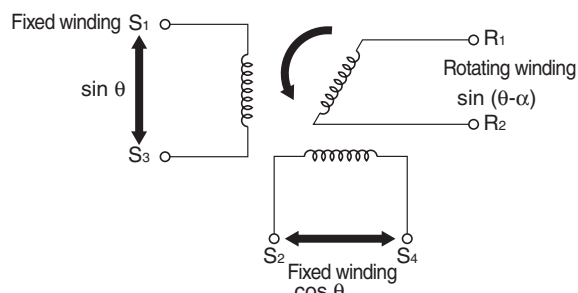

If the fixed winding is locked in position completely in phase with fixed winding $S_1 - S_3$ (energized by $\sin \theta$ voltage) for example, then $\sin \theta$ voltage will be induced in $R_1 - R_2$. When the rotating winding starts rotating, $\sin(\theta - \alpha)$ voltage will be induced in $R_1 - R_2$ because of the $\cos \theta$ voltage of the $S_2 - S_4$ winding that is 90° out of phase with the $S_1 - S_3$ winding. (See the figure below.)

A phase (time) delay or advance of α is detected and measured to determine the absolute angle.

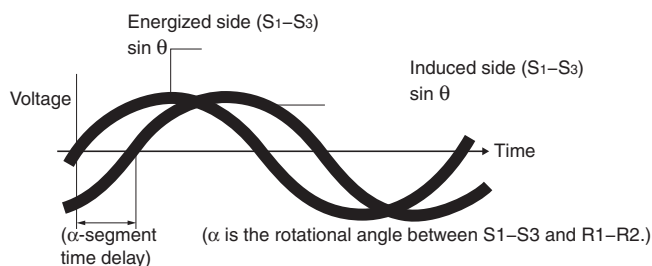

Sensors
Switches
Safety Components
Relays
Control Components
Automation Systems
Motion / Drives
Energy Conservation Support / Environment Measure Equipment
Power Supplies / In Addition
Others
Common

Using an Absolute Encoder to Detect Angles

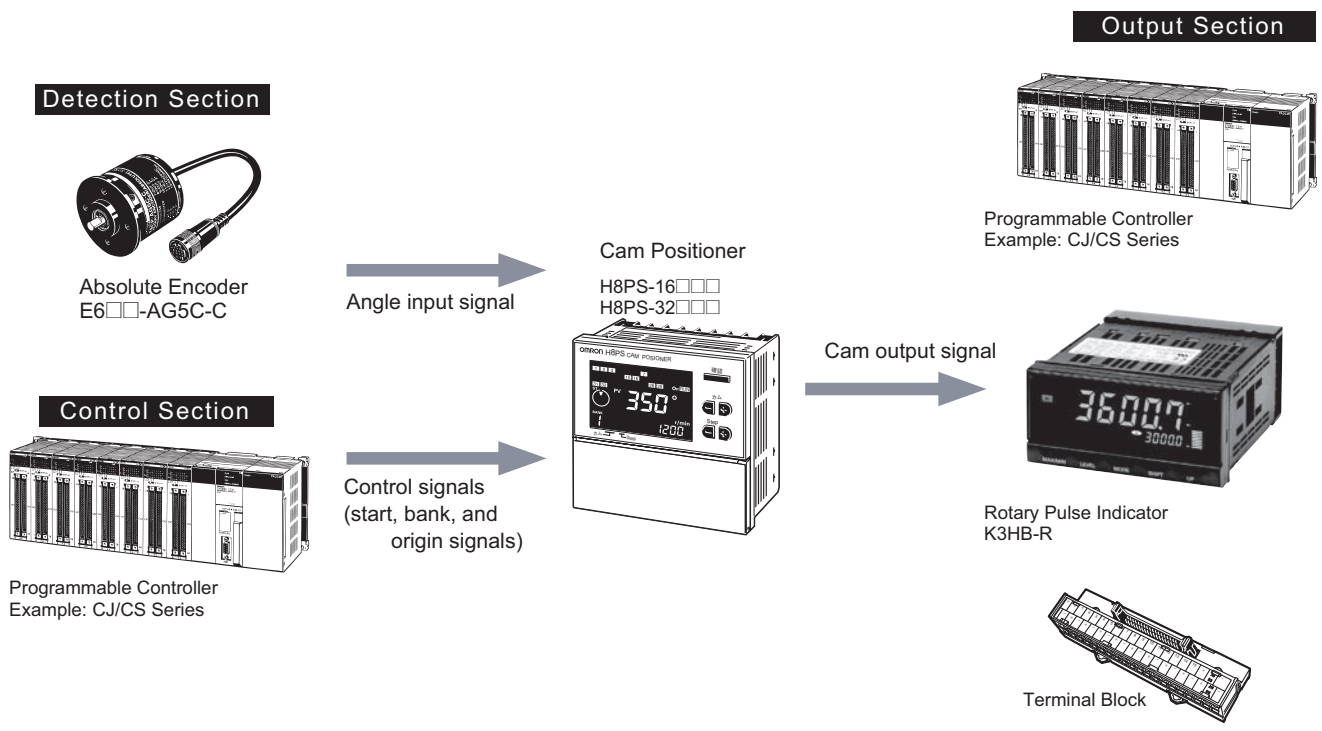

Note: Includes products no longer available to order.

Refer to the *Technical Explanation for Rotary Encoders* for information on the features and operating principles of Absolute Encoders.

- Sensors
- Switches
- Safety Components
- Relays
- Control Components
- Automation Systems
- Motion / Drives
- Energy Conservation Support / Environment Measure Equipment
- Power Supplies / In Addition
- Others
- Common

Explanation of Terms

Cam Positioner

Cam Program

Data containing the ON and OFF angles for the cam output that were set by the user.

Cam Output

An output that is turned ON and OFF according to the detected angle based on the ON and OFF angles set by the user (i.e., the cam program).

Bank

A bank contains one cam program, i.e., one set of cam output settings. The cam program that is used in operation changes when the bank is changed.

Step

One combination of ON and OFF angle settings for the cam.

Programming Example for 360 Resolution

Cam Program (Bank No.1)			
Cam No.	Step	ON angle	OFF angle
1	1	90	180
2	1	315	45
2	2	135	225
3	1	0	45
...

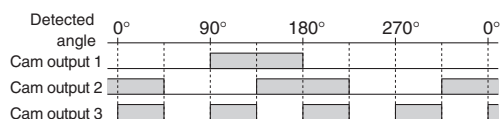

Cam Protection

Protection that can be set for each bank and cam so that the cam ON/OFF angle settings will not be accidentally changed or deleted.

Test Operation

A function to adjust the ON and OFF angles for cam outputs with key inputs to confirm the operation of the mechanical system without inputting external control signals. Test operation is normally used to check the settings in the cam program when commissioning a system.

Adjustment Operation

A function to adjust the ON and OFF angles for cam outputs with key inputs during operation.

This function is normally used to adjust the ON and OFF angles during operation after system application has begun.

Origin

The point that is set as the zero point of the angle detector.

Backlash Compensation

A function to correct for looseness in the mechanical system by establishing differences in the detected angles depending on the direction of rotation. A compensation value that is equivalent to the looseness in the system can be set to align the cam output with specific positions.

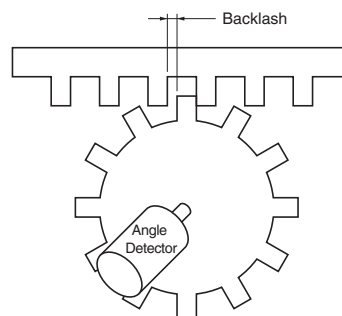

Allowable Thrust and Radial Forces

The thrust and radial forces represent the maximum vertical and horizontal forces that can be applied to a shaft. The magnitude of these forces is proportional to the service life of the product (i.e., the mechanical service life of the bearings).

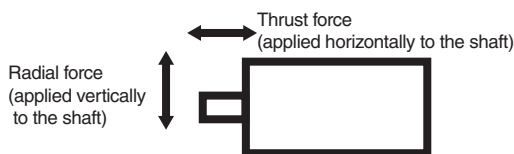

Resolver

Resolution

The number of divisions in one revolution.

Allowable Resolver Speed

The maximum speed at which angle signals can be input from the angle detector. The speed is given as the maximum number of revolutions per minute. The unit is r/min.

Absolute Encoder

Resolution

The number of divisions in one revolution. (A Gray code is output instead of a pulse.)

Response Speed

The same as the allowable Resolver speed.

Sensors

Switches

Safety Components

Relays

Control Components

Automation Systems

Motion / Drives

Energy Conservation Support / Environment Measure Equipment

Power Supplies / In Addition

Others

Common