

Safety Light Curtain

F3SG-4RA□□□□-25-01TS Series

User's Manual



Original instructions

Introduction

Thank you for purchasing the F3SG-4RA□□□□-25-01TS Series Safety Light Curtain (hereinafter referred to as the "F3SG-R"). This is the instruction Manual describing the use of F3SG-R. Always heed the following points when using the F3SG-R:

- Be sure to have F3SG-R be handled by a "Responsible Person" who is well aware of and familiar with the machine to be installed.
- The term "Responsible Person" used in this Instruction Manual means the person qualified, authorized and responsible to secure "safety" in each process of the design, installation, operation, maintenance services and disposition of the machine.
- It is assumed that F3SG-R will be used properly according to the installation environment, performance and function of the machine. Responsible Person should conduct risk assessment on the machine and determine the suitability of this product before installation.
- Read this Manual thoroughly to understand and make good use of the descriptions before installing and operating the product.
- Keep this Manual at the place where the operator can refer to whenever necessary.

Trademarks

The Bluetooth® word mark and logos are registered trademarks owned by Bluetooth SIG, Inc. Any use of such marks by Omron is under license. The names of the other companies and products mentioned herein are the trademarks or registered trademarks of their respective owners.

Legislation and Standards

1. The F3SG-R does not receive type approval provided by Article 44-2 of the Industrial Safety and Health Act of Japan. When using the F3SG-R in Japan as a "safety system for pressing or shearing machines" prescribed in Article 42 of that law, the machine control system must receive type approval.
2. The F3SG-R is electro-sensitive protective equipment (ESPE) in accordance with European Union (EU) Machinery Directive Index Annex V, Item 2.
3. EC/EU Declaration of Conformity
OMRON declares that the F3SG-R is in conformity with the requirements of the following EU Directives:
Machinery Directive 2006/42/EC
EMC Directive 2014/30/EU
4. Conforming Standards
 - (1) European standards
EN61496-1 (Type 4 ESPE), EN 61496-2 (Type 4 AOPD), EN61508-1 through -4 (SIL 3 for Type 4),
EN ISO 13849-1:2008 (PL e, Category 4 for Type 4)
 - (2) International standards
IEC61496-1 (Type 4 ESPE), IEC61496-2 (Type 4 AOPD), IEC61508-1 through -4 (SIL 3 for Type 4),
ISO 13849-1:2006 (PL e, Category 4 for Type 4)
 - (3) JIS standards
JIS B 9704-1 (Type 4 ESPE), JIS B 9704-2 (Type 4 AOPD)
 - (4) North American standards
UL61496-1(Type 4 ESPE), UL61496-2(Type 4 AOPD), UL508, UL1998,
CAN/CSA C22.2 No.14, CAN/CSA C22.2 No.0.8
 - (5) Chinese standards
GB4584(Specification of active opto-electronic protective devices for presses)
5. Third-Party Certifications
 - (1) TÜV SÜD
 - EC Type-Examination certificate:
EU Machinery Directive, Type 4 ESPE (EN61496-1), Type 4 AOPD (EN 61496-2)
 - Certificate:
Type 4 ESPE (EN61496-1), Type 4 AOPD (EN61496-2), EN 61508-1 through -4 (SIL 3 for Type 4), EN
ISO 13849-1:2008 (PL e, Category 4 for Type 4)
 - (2) UL
 - UL Listing:
Type 4 ESPE (UL61496-1), Type 4 AOPD (UL61496-2), UL508, UL1998, CAN/CSA C22.2 No.14, CAN/
CSA C22.2 No.0.8
 - (3) China National Casting and Forging Machines Quality Supervision and Inspection Center
 - Certificate:
GB4584 (Specification of active opto-electronic protective devices for presses) (Type 4)

6. Other Standards

The F3SG-R is designed according to the standards listed below. To make sure that the final system complies with the following standards and regulations, you are asked to design and use it in accordance with all other related standards, laws, and regulations. If you have any questions, consult with specialized organizations such as the body responsible for prescribing and/or enforcing machinery safety regulations in the location where the equipment is to be used.

- European Standards: EN415-4, EN691-1, EN692, EN693, IEC/TS 62046
- U.S. Occupational Safety and Health Standards: OSHA 29 CFR 1910.212
- U.S. Occupational Safety and Health Standards: OSHA 29 CFR 1910.217
- American National Standards: ANSI B11.1 to B11.19
- American National Standards: ANSI/RIA R15.06
- Canadian Standards Association CSA Z142, Z432, Z434
- SEMI Standards SEMI S2
- Japan Ministry of Health, Labour and Welfare "Guidelines for Comprehensive Safety Standards of Machinery", Standard Bureau's Notification No. 0731001 dated July 31, 2007.rms and Conditions Agreement
- Chinese National Standards: GB17120, GB27607

Terms and Conditions Agreement

Warranties.

- (a) Exclusive Warranty. Omron's exclusive warranty is that the Products will be free from defects in materials and workmanship for a period of twelve months from the date of sale by Omron (or such other period expressed in writing by Omron). Omron disclaims all other warranties, express or implied.
- (b) Limitations. OMRON MAKES NO WARRANTY OR REPRESENTATION, EXPRESS OR IMPLIED, ABOUT NON-INFRINGEMENT, MERCHANTABILITY OR FITNESS FOR A PARTICULAR PURPOSE OF THE PRODUCTS. BUYER ACKNOWLEDGES THAT IT ALONE HAS DETERMINED THAT THE PRODUCTS WILL SUITABLY MEET THE REQUIREMENTS OF THEIR INTENDED USE. Omron further disclaims all warranties and responsibility of any type for claims or expenses based on infringement by the Products or otherwise of any intellectual property right.
- (c) Buyer Remedy. Omron's sole obligation hereunder shall be, at Omron's election, to (i) replace (in the form originally shipped with Buyer responsible for labor charges for removal or replacement thereof) the non-complying Product, (ii) repair the non-complying Product, or (iii) repay or credit Buyer an amount equal to the purchase price of the non-complying Product; provided that in no event shall Omron be responsible for warranty, repair, indemnity or any other claims or expenses regarding the Products unless Omron's analysis confirms that the Products were properly handled, stored, installed and maintained and not subject to contamination, abuse, misuse or inappropriate modification. Return of any Products by Buyer must be approved in writing by Omron before shipment. Omron Companies shall not be liable for the suitability or unsuitability or the results from the use of Products in combination with any electrical or electronic components, circuits, system assemblies or any other materials or substances or environments. Any advice, recommendations or information given orally or in writing, are not to be construed as an amendment or addition to the above warranty.
- See <http://www.omron.com/global/> or contact your Omron representative for published information.

Limitation on Liability: Etc.

OMRON COMPANIES SHALL NOT BE LIABLE FOR SPECIAL, INDIRECT, INCIDENTAL, OR CONSEQUENTIAL DAMAGES, LOSS OF PROFITS OR PRODUCTION OR COMMERCIAL LOSS IN ANY WAY CONNECTED WITH THE PRODUCTS, WHETHER SUCH CLAIM IS BASED IN CONTRACT, WARRANTY, NEGLIGENCE OR STRICT LIABILITY.

Further, in no event shall liability of Omron Companies exceed the individual price of the Product on which liability is asserted.

Suitability of Use.

Omron Companies shall not be responsible for conformity with any standards, codes or regulations which apply to the combination of the Product in the Buyer's application or use of the Product. At Buyer's request, Omron will provide applicable third party certification documents identifying ratings and limitations of use which apply to the Product. This information by itself is not sufficient for a complete determination of the suitability of the Product in combination with the end product, machine, system, or other application or use. Buyer shall be solely responsible for determining appropriateness of the particular Product with respect to Buyer's application, product or system. Buyer shall take application responsibility in all cases.

NEVER USE THE PRODUCT FOR AN APPLICATION INVOLVING SERIOUS RISK TO LIFE OR PROPERTY WITHOUT ENSURING THAT THE SYSTEM AS A WHOLE HAS BEEN DESIGNED TO ADDRESS THE RISKS, AND THAT THE OMRON PRODUCT(S) IS PROPERLY RATED AND INSTALLED FOR THE INTENDED USE WITHIN THE OVERALL EQUIPMENT OR SYSTEM.

Programmable Products.

Omron Companies shall not be responsible for the user's programming of a programmable Product, or any consequence thereof.

Performance Data.

Data presented in Omron Company websites, catalogs and other materials is provided as a guide for the user in determining suitability and does not constitute a warranty. It may represent the result of Omron's test conditions, and the user must correlate it to actual application requirements. Actual performance is subject to the Omron's Warranty and Limitations of Liability.

Change in Specifications.

Product specifications and accessories may be changed at any time based on improvements and other reasons. It is our practice to change part numbers when published ratings or features are changed, or when significant construction changes are made. However, some specifications of the Product may be changed without any notice. When in doubt, special part numbers may be assigned to fix or establish key specifications for your application. Please consult with your Omron's representative at any time to confirm actual specifications of purchased Product.

Errors and Omissions.

Information presented by Omron Companies has been checked and is believed to be accurate; however, no responsibility is assumed for clerical, typographical or proofreading errors or omissions.



Safety Precautions

Indications and Meanings for Safe Use



The precautions listed in this document indicated by alert symbols and statements must be followed for the safe use of the F3SG-R. Failure to follow all precautions and alerts may result in an unsafe use or operation. Thoroughly read this manual and understand the installation procedures, operation check procedures, and maintenance procedures before using F3SG-R.

The following word and symbols are used in this document.

Meaning of Signal Word

 DANGER	Indicates an imminently hazardous situation which, if not avoided, is likely to result in serious injury or may result in death. Additionally there may be severe property damage.
 WARNING	Indicates a potentially hazardous situation which, if not avoided, will result in minor or moderate injury, or may result in serious injury or death. Additionally there may be significant property damage.

Meanings of Alert Symbols

	Indicates prohibited actions.
	Indicates mandatory actions.
	Indicates the risk of electric shock.

Alert Statements in this Manual

DANGER

Make sure to test the operation of the F3SG-R after setting with DIP Switch to verify that the F3SG-R operates as intended. Make sure to stop the machine until the test is complete. Unintended settings may cause a person to go undetected, resulting in serious injury or death.



For users

WARNING

The F3SG-R must be installed, configured, and incorporated into a machine control system by a sufficiently trained and qualified person. An unqualified person may not be able to perform these operations properly, which may cause a person to go undetected, resulting in serious injury.



For machines

 **WARNING**

Do not use this sensor for machines that cannot be stopped by electrical control. For example, do not use it for a pressing machine that uses full-rotation clutch. Otherwise, the machine may not stop before a person reaches the hazardous part, resulting in serious injury.



To use F3SG-R in PSDI mode (initiation of cycle operations by a presence sensing device), you must configure an appropriate circuit between F3SG-R and the machine. For details about PSDI, refer to OSHA1910.217, IEC61496-1, and other relevant standards and regulations.



For installation

 **WARNING**

Make sure Responsible Person tests the operation of the F3SG-R after installation to verify that the F3SG-R operates as intended. Make sure to stop the machine until the test is complete. Unintended installation, wiring or function settings may cause a person to go undetected, resulting in serious injury.



Make sure to install the F3SG-R at the safety distance from the hazardous part of the machine. Otherwise, the machine may not stop before a person reaches the hazardous part, resulting in serious injury.



Install a protective structure so that the hazardous part of a machine can only be reached by passing through the sensor's detection zone. If access to the hazardous part by reaching over the detection zone of a vertically mounted F3SG-R cannot be excluded, the height of the detection zone and the safety distance shall be determined in consideration of such a risk. Install the sensors so that part of the person is always present in the detection zone when working in a machine's hazardous zones. If a person is able to step into the hazardous zone of a machine and remain behind the F3SG-R's detection zone, configure the system with Restart Interlock function due to unexpected startup. Failure to do so may result in serious injury.



Install the reset switch to the position that the entire hazardous zone is visible, and it can not be operated from the hazardous zone.



The F3SG-R cannot protect a person from a projectile exiting the hazardous zone. Install protective cover(s) or fence(s).



Install F3SG-R so that it is not affected by reflective surfaces. Failure to do so may hinder detection, resulting in serious injury. For an installation distance from reflective surfaces, see 4-1-3. *Distance from Reflective Surfaces*.



When using more than 1 set of F3SG-R in adjacent areas, the emitter of one F3SG-R may interfere with the receiver of the other, causing the safety functions to stop working properly. Install and configure them so that mutual interference does not occur.



Make sure that foreign material such as water, oil, or dust does not enter the F3SG-R or the connector while the cap or the cover of the DIP Switch is removed.



Do not use the sensor system with mirrors in a retro-reflective configuration as shown below. Doing so may hinder detection. It is possible to use mirrors to alter the detection zone to a 90-degree angle.

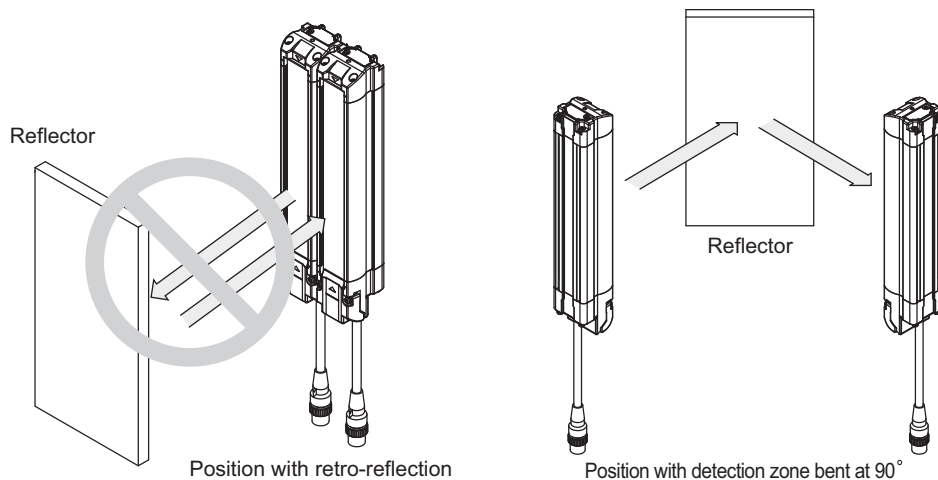

Perform an inspection for all F3SG-R as described in *Chapter 6 Checklists*. When using cascade connections, perform inspections for every connected F3SG-R.



For wiring

WARNING

When using the PNP output, connect the load between the output and 0 V line. When using the NPN output, connect the load between the output and +24 VDC line. Connecting the load between the output and a different power supply line from the above will result in a dangerous condition because the operation mode of safety output is reversed to "Dark-ON".



When using the PNP output, do not ground +24 VDC line. When using the NPN output, do not ground 0 V line. Otherwise, a ground fault may turn the safety output ON, resulting in a failure of stopping the machine.



Configure the system by using the optimal number of safety outputs that satisfy the requirements of the necessary safety category.



Do not connect each line of F3SG-R to a DC power supply of higher than 24 VDC+20%. Also, do not connect it to an AC power supply. Failure to do so may result in electric shock.



Make sure to perform wiring while the power supply is OFF.



Do not use the auxiliary output for safety applications. Failure to do so may result in serious injury when the F3SG-R fails.



For the F3SG-R to comply with IEC 61496-1 and UL 508, the DC power supply unit must satisfy all of the following conditions:

- Must be within the rated power voltage (24 VDC \pm 20%)
- Must have tolerance against the total rated current of devices if it is connected to multiple devices
- Must comply with EMC directives (industrial environment)
- Double or reinforced insulation must be applied between the primary and secondary circuits
- Automatic recovery of overcurrent protection characteristics
- Output holding time must be 20ms or longer
- Must satisfy output characteristic requirements for class 2 circuit or limited voltage current circuit defined by UL508. Refer to 4-5-2. *Power Supply Unit*.
- Must comply with laws and regulations, regarding EMC and electrical equipment safety, of the country or region where the F3SG-R is used (For example, in EU, the power supply must comply with the EMC Directive and the Low Voltage Directive.)



Double or reinforced insulation from hazardous voltage must be applied to all input and output lines. Failure to do so may result in electric shock.



Extension of the cable must be within a specified length. If it isn't, safety function may not work properly, resulting in danger.



Other

WARNING

Do not try to disassemble, repair, or modify this product. Doing so may cause the safety functions to stop working properly.



Do not use the F3SG-R in environments where flammable or explosive gases are present. Doing so may result in explosion.



Perform daily and 6-month inspections for the F3SG-R as described in *Chapter 6 Checklists*. Otherwise, the system may fail to work properly, resulting in serious injury.



Do not use the F3SG-R in environments where strong electromagnetic field may be produced. Doing so may cause the safety functions to stop working properly.



Precautions for Safe Use

Make sure to observe the following precautions that are necessary for ensuring safe use of the product.

Do not install, use, or store the F3SG-R in the following types of environments:

- Areas exposed to intense interference light, such as direct sunlight
 - Areas with high humidity where condensation is likely to occur
 - Areas where oil mist or corrosive gases are present
 - Areas exposed to vibration or shock levels higher than in the specification provisions
 - Areas where the product may come into contact with water
 - Areas where the pollution degree is harsher than 3, such as outdoor environment
 - Areas where the product may get wet with oil that can solve adhesive
- Loads must satisfy both of the following conditions:
 - Not short-circuited
 - Not used with a current that is higher than the rating
 - Do not drop the product.
 - Dispose of the product in accordance with the relevant rules and regulations of the country or area where the product is used.
 - Make sure that the F3SG-R is securely mounted and its cables and connectors are properly secured based on the torque recommended in this document.
 - Bending radii of cables must be equal to or higher than specified minimum values.
 - When replacing the cable connectors with other types of connectors, use connectors that provide a protection grade of IP54 or higher.
 - Be sure to route the input/output lines for the F3SG-R separate from high-potential power lines or through an exclusive conduit.
 - To extend a cable length with a cable other than the dedicated cable, use a cable with the same or superior specifications.
-  Refer to 4-5-3-4. *Extending Cable Length with Commercially Available Cable*
- In environments where foreign material such as spatter adheres to the F3SG-R, attach a cover to protect the F3SG-R from the spatter.
 - Read and understand this document for DIP Switch setting.
 - The rated life of this product is 6 years.

Precautions for Correct Use

Observe the precautions described below to prevent operation failure, malfunctions, or undesirable effects on product performance.

■ Storage conditions and installation environment

- Do not install, use, or store the F3SG-R for a long time at a temperature or humidity out of the specified range.
- This is a class A product. In residential areas it may cause radio interference, in which case the Responsible Person may be required to take adequate measures to reduce interference.

■ Wiring and installation

- Properly perform the wiring after confirming the signal names of all the terminals.
- Be sure that there is nothing in the detection zone and the stable-state indicator is turned ON after power is turned ON.
- Do not operate the control system until 2 seconds or more after turning ON the power of the F3SG-R.
- When using a commercially available switching regulator power supply, make sure to ground the PE terminal (protective earth terminal).
- Install the emitter and receiver to the same vertical direction.
- Use brackets of specified quantities and locations according to the dimensions.
If the brackets described above are not used, ratings and performance cannot be met.
- Do not install the F3SG-R close to a device that generates high-frequency noise. Otherwise, take sufficient blocking measures.

■ Cleaning

- Do not use thinner, benzene, or acetone for cleaning. They affect the product's resin parts and paint on the housing.

■ Object detection

- The F3SG-R cannot detect transparent and/or translucent objects.

■ Settings

- Do not operate the DIP Switch during normal operation of the F3SG-R. Otherwise, the F3SG-R enters the Lockout state.
- Do not operate the DIP Switch with tools that may damage the product.

Visual Aids

The following symbols appear in this document to help you locate different types of information.



Indicates important information or advice on a function or operation of the product.



Indicates page numbers or chapter title of related information.



Table of Contents

Legislation and Standards	i
Terms and Conditions Agreement	iii
Safety Precautions	v
Precautions for Safe Use	ix
Precautions for Correct Use	x
Visual Aids	xi
Chapter1 Overview and Specifications	1
1-1. What is Included	2
1-2. System Components	3
1-2-1. Basic Components	4
1-2-2. Model Overview	5
1-3. List of Features	6
1-3-1. Model Overview	6
1-3-2. List of Features	6
1-4. LED Indicators	7
1-4-1. LED Indicator Status	8
1-5. Ratings/Specifications	9
1-6. List of Models	12
1-6-1. List of Models/Response Time/Current Consumption/Weight	12
1-6-2. Calculation of Response Time of Cascaded Segments	13
Chapter2 System Operation and Functions	15
2-1. Operating States	16
2-1-1. Machine Run State	16
2-1-2. Machine Stop State	16
2-1-3. Lockout State	16
2-2. Optical Synchronization	17
2-2-1. Overview	17
2-3. Scan Code Selection	18
2-3-1. Overview	18
2-3-2. Factory Default Setting	18
2-3-3. Setting with DIP Switch	18
2-4. PNP/NPN Selection	19
2-4-1. Overview	19
2-4-2. Factory Default Setting	19
2-4-3. Setting with DIP Switch	19
2-5. Self-Test	20
2-5-1. Overview	20

2-5-1-1. Self-Test details	20
2-5-1-2. Waveform of safety outputs	21
2-6. External Test	22
2-6-1. Overview	22
2-6-2. Factory Default Setting	22
2-6-3. Setting with DIP Switch	22
2-7. Lockout Reset	23
2-7-1. Overview	23
2-8. External Device Monitoring (EDM)	24
2-8-1. Overview	24
2-8-2. Factory Default Setting	25
2-8-3. Setting with DIP Switch	25
2-9. Auxiliary Output	26
2-9-1. Overview	26
2-10. Operating Range Selection	27
2-10-1. Overview	27
2-10-2. Factory Default Setting	27
2-10-3. Setting with DIP Switch	27
2-11. Lamp	28
2-11-1. Overview	28
2-11-2. Setting with DIP Switch	28
Chapter3 Setting with DIP Switch	31
3-1. List of Features Configurable by DIP Switch	32
3-2. DIP Switch	33
3-2-1. DIP Switch on Receiver	34
3-2-2. DIP Switch on Emitter	34
Chapter4 Wiring/Installation	35
4-1. Installation Considerations	37
4-1-1. Detection Zone and Approach	37
4-1-2. Safety Distance	38
4-1-2-1. Safety Distance Formulas according to ISO 13855/EN ISO 13855	38
4-1-2-2. Safety Distance Formulas according to ANSI B11.19	41
4-1-3. Distance from Reflective Surfaces	42
4-1-4. Mutual Interference Prevention	43
4-2. Cascade Connection	44
4-2-1. Overview	44
4-2-2. Connection Procedure	46
4-3. Dimensions	47

4-3-1. Mounted with Standard Fixed Brackets (F39-LGF)	47
4-3-1-1. External Dimensions	47
4-3-1-2. Standard Fixed Bracket	49
4-3-2. Mounted with Standard Adjustable Brackets (F39-LGA)	50
4-3-2-1. External Dimensions	50
4-3-2-2. Standard Adjustable Bracket	52
4-3-3. Mounted with Top/Bottom Adjustable Brackets (F39-LGTB) and Standard Adjustable Brackets (F39-LGA)	53
4-3-3-1. External Dimensions	53
4-3-3-2. Top/Bottom Adjustable Bracket (F39-LGTB)	58
4-3-3-3. Top/Bottom Adjustable Bracket (F39-LGTB-1)	59
4-4. Mounting	60
4-4-1. Mounting Method	60
4-4-2. Number of Brackets Required	60
4-4-3. Mounting Procedure	61
4-4-3-1. Mounting with Standard Fixed Brackets (F39-LGF)	61
4-4-3-2. Mounting with Standard Adjustable Brackets (F39-LGA)	62
4-4-3-3. Mounting with Top/Bottom Adjustable Brackets (F39-LGTB)	65
4-4-4. Beam Alignment Procedure	68
4-5. Wiring	69
4-5-1. Wiring Precautions	69
4-5-2. Power Supply Unit	70
4-5-3. Cable Connections	71
4-5-3-1. Single-Ended Cable	71
4-5-3-2. Double-Ended Cable	72
4-5-3-3. Cascading Cable	74
4-5-3-4. Extending Cable Length with Commercially Available Cable	75
4-5-4. Functional Earth Connection	76
Chapter5 Input/Output Circuit and Applications	77
5-1. Input/Output Circuit	78
5-1-1. Entire Circuit Diagram	78
5-1-2. Input Circuit Diagram by Function	80
5-2. Wiring Examples	81
5-2-1. Standalone F3SG-R using PNP Outputs	81
5-2-2. Standalone F3SG-R using NPN Outputs	82
5-3. Connectable Safety Control Units	83
Chapter6 Checklists	85
6-1. Pre-Operation Checklists	86
6-1-1. Checklists	86

6-1-1-1. Installation Condition Check	86
6-1-1-2. Wiring Check Before Power Is Turned ON	86
6-1-1-3. Operation Check While the Machine Is Stopped	87
6-1-1-4. Checking that Hazardous Parts Stop While the Machine Operates	87
6-2. Maintenance Checklists	88
6-2-1. Checklists	88
6-2-1-1. Inspection at Startup and When Changing Operators	88
6-2-1-2. Checking that Hazardous Parts Stop While the Machine Operates	89
6-2-1-3. Items to Inspect Every 6 Months or When Machine Settings Are Changed	89
Chapter7 Appendix	91
7-1. Troubleshooting	92
7-1-1. Lockout State	92
7-1-1-1. Description	92
7-1-1-2. Troubleshooting	93
7-1-2. Warning	96
7-1-2-1. Description	96
7-1-2-2. Troubleshooting	96
7-1-3. Troubles other than in Lockout State	97
7-2. Optional Accessories(Sold Separately)	98
7-3. Glossary	104
7-4. Revision History	105

Chapter 1 Overview and Specifications

1-1. What is Included	2
1-2. System Components	3
1-2-1. Basic Components	4
1-2-2. Model Overview	5
1-3. List of Features	6
1-3-1. Model Overview	6
1-3-2. List of Features	6
1-4. LED Indicators	7
1-4-1. LED Indicator Status	8
1-5. Ratings/Specifications	9
1-6. List of Models	12
1-6-1. List of Models/Response Time/Current Consumption/Weight	12
1-6-2. Calculation of Response Time of Cascaded Segments	13

1-1. What is Included

Before use, confirm that the items below are included with the product.

If you find that an item is missing, please contact your local branch office or distributor.

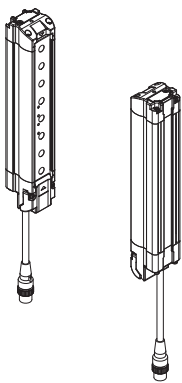
Product	Quantity
<p>F3SG-4RA□□□□-25-01TS</p> 	<p>Emitter x 1, Receiver x 1</p>
<p>Troubleshooting Guide Sticker</p>	<p>1</p>
<p>Safety Precautions</p>	<p>1</p>
<p>Quick Installation Manual</p>	<p>1</p>

1-2. System Components

This section describes the system components and part names of the F3SG-R system.

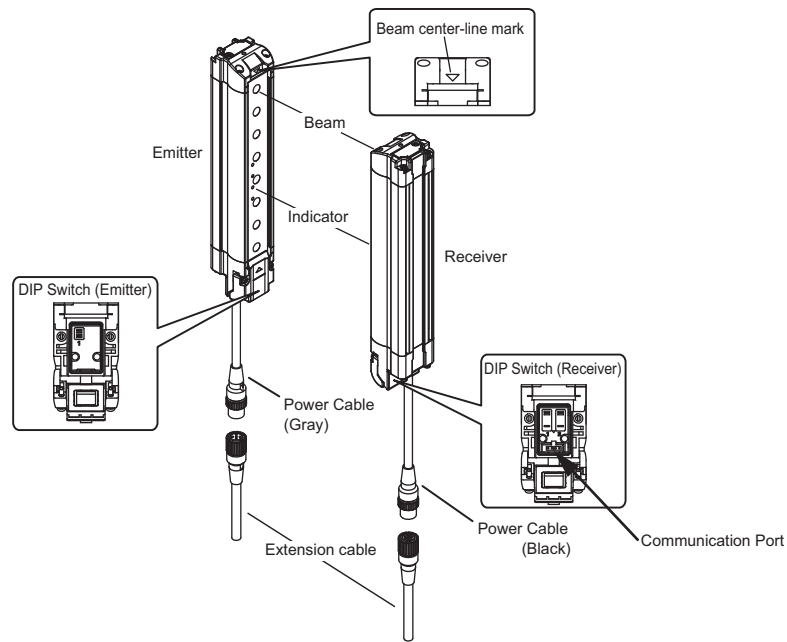

1-2-2. Model Overview

The F3SG-R safety light curtain family is available in two ESPE types, Type 4 according to EN 61496-1, identified as follows:

F3SG-4RA□□□□□□□□ : Type 4 ESPE

(These are also referred to as the "F3SG-RA".)

The F3SG-RA is multi-functional and designed for various applications.

 Refer to *Chapter 2 System Operation and Functions* for more information on available features.

1-3. List of Features

1-3-1. Model Overview

The model name is represented as F3SG-4RA□□□□-25-01TS.
Refer to the List of Features below for available features.

1-3-2. List of Features

The F3SG-4RA-25-01TS safety light curtain family has the following features. The following features are available or configurable by the DIP Switch on the body of the safety light curtain.

Feature	F3SG-RA Series		Page
	Setting by DIP Switch	Factory default setting	
Scan Code Selection	X	Code A	p.18
PNP/NPN Selection	X	PNP output	p.19
External Test	X	24 V Inactive	p.22
External Device Monitoring(EDM)	X	Disabled	p.24
Operating Range Selection	X	Long mode	p.27

1-4-1. LED Indicator Status

Shown below are indication statuses of F3SG-R LED indicators when you purchased.

Emitter

Location	Name of Indicator	Color	Illuminated	Blinking
1	TEST	Green	-	External Test is being performed
2	LONG	Green	Long range mode is selected	Lockout state due to DIP Switch setting error or Operating range selection setting error
3	POWER	Green	Power is ON.	Error due to noise
4	LOCKOUT	Red	-	Lockout state due to error in emitter

Receiver

Location	Name of Indicator	Color	Illuminated	Blinking
1	TOP	Blue	The top beam is unblocked	Lockout state due to Cap error or Other sensor error
2	NPN	Green	NPN mode is selected by DIP Switch	-
3	CFG	Green	-	Lockout state due to Cascading Configuration error
4	EDM	Green	EDM input is in ON state *	Lockout state due to EDM error
5	INTERNAL	Red	-	Lockout state due to Internal error, or error due to abnormal power supply or noise
6	LOCKOUT	Red	-	Lockout state due to error in receiver
7	STB	Green	Incident light level is 170% or higher of ON-threshold	Safety output is instantaneously turned OFF due to ambient light or vibration
8	ON/OFF	Green	Safety output is in ON state	-
		Red	Safety output is in OFF state	Lockout state due to Safety Output error, or error due to abnormal power supply or noise
9	COM	Green	Synchronization between emitter and receiver is maintained	Lockout state due to Communication error, or error due to abnormal power supply or noise
10	BTM	Blue	The bottom beam is unblocked	Lockout state due to DIP Switch setting error



* The LED is illuminated when the EDM input is in ON state regardless of wiring with EDM used or unused.









Refer to 7-3. Glossary for definitions of terms used in the table above.

1-5. Ratings/Specifications

The □□□□ in the model names indicate the protective heights in millimeters.

		F3SG-4RA□□□□-25-01TS
Type of ESPE (IEC 61496-1)	Type 4	F3SG-4RA□□□□-25-01TS
Performance		
Object Resolution (Detection Capability)	Opaque objects 25-mm dia.	
Beam Gap	20 mm	
Number of Beams	8 to 96	
Lens Size	6.0×5.0 (W×H) mm	
Protective Height	185 to 1945 mm (7.3 to 76.6 inch)	
Operating Range	Long	0.3 to 17.0 m (1 to 56 ft.)
	Short	0.3 to 5.0 m (1 to 16 ft.)
Response Time	ON to OFF	8 to 13 ms *1
	OFF to ON	40 to 65ms *1
	*1. Response time when used in one segment system or in cascaded connection.  Refer to 1-6. <i>List of Models</i> and 2-2. <i>Optical Synchronization</i> for more information.	
Effective Aperture Angle (EAA) (IEC 61496-2)	Type 4	±2.5° max., emitter and receiver at operating range of 3 m or greater
Light Source	Infrared LEDs, Wavelength: 870 nm	
Startup Waiting Time	2 s max.	
Electrical		
Power Supply Voltage (Vs)	SELV/PELV 24 VDC±20% (ripple p-p 10% max.)	
Current Consumption	 Refer to 1-6. <i>List of Models</i>	
Safety Outputs (OSSD)	Two PNP or NPN transistor outputs (PNP or NPN is selectable by DIP Switch.) Load current of 300 mA max., Residual voltage of 2 V max. (except for voltage drop due to cable extension), Capacitive load of 1 μF max., Inductive load of 2.2 H max. *1 Leakage current of 1 mA max. (PNP), 2 mA max. (NPN) *2	
	*1. The load inductance is the maximum value when the safety output frequently repeats ON and OFF. When you use the safety output at 4 Hz or less, the usable load inductance becomes larger. *2. These values must be taken into consideration when connecting elements including a capacitive load such as a capacitor.	
Auxiliary Output	One PNP or NPN transistor output (Safety Output and homopolarity) Load current of 100 mA max., Residual voltage of 2 V max .	
Output Operation Mode	Safety Output	Light-ON (Safety output is enabled when the receiver receives an emitting signal.)
	Auxiliary Output	Reverse output of safety output
Input Voltage	External device monitoring input (Lockout reset input)	PNP ON voltage: Vs-3 V to Vs (short circuit current: approx. 6.5 mA) * OFF voltage: 0 V to 1/2 Vs, or open (short circuit current: approx. 8.0 mA) * NPN ON voltage: 0 V to 3 V (short circuit current: approx. 8.0 mA) * OFF voltage: 1/2 Vs to Vs, or open (short circuit current: approx. 6.5 mA) *
	Test input	TEST: 24 V inactive setting ON voltage: 0 V to 1.5 V or open (short circuit current: approx. 2.0 mA) OFF voltage: 9 V to Vs (short circuit current: approx. 2.5 mA) * 0 V inactive setting ON voltage: 9 V to Vs or open (short circuit current: approx. 2.5 mA) OFF voltage: 0 V to 3 V (short circuit current: approx. 2.0 mA)
	* The Vs indicates a supply voltage value in your environment.	
Overvoltage Category (IEC 60664-1)	II	

		F3SG-4RA□□□□-25-01TS
Indicators	 Refer to 1-4-1. LED Indicator Status	
Protective Circuit	Output short protection, Power supply reverse polarity protection	
Insulation Resistance	20 MΩ or higher (500 VDC megger)	
Dielectric Strength	1,000 VAC, 50/60 Hz (1 min)	
Functional		
Mutual Interference Prevention (Scan Code)	This function prevents mutual interference in up to two F3SG-RA systems.  4-1-4. Mutual Interference Prevention	
Cascade Connection	Number of cascaded segments: 3 max. Total number of beams: 255 max. Cable length between sensors: 10 m max.	
Test Function	Self-test (at power-on, and during operation) External test (light emission stop function by test input)	
Safety-Related Functions	External device monitoring (EDM) Scan code selection PNP/NPN selection  Chapter 3 Setting with DIP Switch	
Environmental		
Ambient Temperature	Operating	-10 to 55°C (14 to 131°F) (non-icing)
	Storage	-25 to 70°C (-13 to 158°F)
Ambient Humidity	Operating	35% to 85% (non-condensing)
	Storage	35% to 95%
Ambient Illuminance	Incandescent lamp: 3,000 lx max. on receiver surface Sunlight: 10,000 lx max. on receiver surface	
Degree of Protection (IEC 60529)	IP65 and IP67	
Vibration Resistance (IEC 61496-1)	10 to 55 Hz, Multiple amplitude of 0.7 mm, 20 sweeps for all 3 axes	
Shock Resistance (IEC 61496-1)	100 m/s ² , 1000 shocks for all 3 axes	
Pollution Degree (IEC 60664-1)	Pollution Degree 3	
Connections		
Power cable	Type of Connection	M12 connectors: 8-pin emitter and receiver, IP67 rated when mated, Cables prewired to the sensors
	Number of Wires	On emitter: 5-wire, On receiver: 8-wire
	Cable Length	0.3 m
	Cable Diameter	6 mm
	Minimum Bending Radius	R5 mm
Cascading cable	Type of Connection	M12 connectors: 8-pin emitter and receiver, IP67 rated when mated
	Number of Wires	On emitter: 5-wire, On receiver: 8-wire
	Cable Length	0.2 m
	Cable Diameter	6 mm
	Minimum Bending Radius	R5 mm

		F3SG-4RA□□□□-25-01TS
Extension cable - Single-ended cable - Double-ended cable	Type of Connection	M12 connectors: 8-pin emitter and receiver, IP67 rated when mated
	Number of Wires	On emitter and receiver: 8-wire
	Cable Length	 Refer to 4-5-3-1. <i>Single-Ended Cable</i> and 4-5-3-2. <i>Double-Ended Cable</i> for cable lengths and twisted pair wires.
	Cable Diameter	6.6 mm
	Minimum Bending Radius	R36 mm
Extension of Power Cable		100 m max.(Emitter/Receiver)
Material		
Material		Housing: Aluminum Cap: PBT Front window: PMMA Cable: Oil resistant PVC FE plate: SUS
Weight (packaged)		 Refer to 1-6. <i>List of Models</i>
Included Accessories		Safety Precautions, Quick Installation Manual, Troubleshooting Guide Sticker,
Conformity		
Conforming standards		 Refer to <i>Legislation and Standards</i>
Performance Level (PL)/ Safety category		Type 4
PFHd		1.1×10^{-8} (IEC 61508)
Proof test interval T_M		Every 20 years (IEC 61508)
SFF		99% (IEC 61508)
HFT		1 (IEC 61508)
Classification		Type B (IEC 61508-2)

1-6. List of Models

1-6-1. List of Models/Response Time/Current Consumption/Weight

F3SG-4RA□□□□-25-01TS

Model	Number of Beams	Protective Height [mm]	Response Time[ms]			Current Consumption [mA]		Weight [kg] *3
			ON→OFF *1	OFF (Synchronized) →ON *2	OFF (Not synchronized) →ON *2	Emitter	Receiver	
F3SG-4RA0185-25	8	185	8	40	140	35	75	1.2
F3SG-4RA0265-25	12	265	8	40	140	35	75	1.4
F3SG-4RA0345-25	16	345	8	40	140	40	75	1.6
F3SG-4RA0425-25	20	425	8	40	140	45	75	2.1
F3SG-4RA0505-25	24	505	8	40	140	50	75	2.3
F3SG-4RA0585-25	28	585	8	40	140	50	75	2.4
F3SG-4RA0665-25	32	665	8	40	140	55	75	2.6
F3SG-4RA0745-25	36	745	8	40	140	60	80	3.1
F3SG-4RA0825-25	40	825	8	40	140	65	80	3.2
F3SG-4RA0905-25	44	905	13	65	165	50	80	3.4
F3SG-4RA0985-25	48	985	13	65	165	50	80	3.6
F3SG-4RA1065-25	52	1065	13	65	165	55	80	3.8
F3SG-4RA1145-25	56	1145	13	65	165	55	85	4.5
F3SG-4RA1225-25	60	1225	13	65	165	55	85	4.6
F3SG-4RA1305-25	64	1305	13	65	165	60	85	4.8
F3SG-4RA1465-25	72	1465	13	65	165	65	85	5.3
F3SG-4RA1625-25	80	1625	13	65	165	70	90	6.0
F3SG-4RA1785-25	88	1785	13	65	165	70	90	6.4
F3SG-4RA1945-25	96	1945	13	65	165	75	95	6.7

*1. The response times are values when Scan Code is set at Code B. The response times for Code A are 1 ms shorter than these values.

*2. Refer to 2-2. *Optical Synchronization* for more information.

*3. The weight includes an emitter and a receiver in a product package.





The maximum operating speed of the test rod which can maintain the object resolution is 2.0 m/s.

1-6-2. Calculation of Response Time of Cascaded Segments

The F3SG-4RA□□□□-25-01TS Series can be used in cascade connection with each other. In case of a cascade connection, a response time is determined by the total number of beams. If the total number of beams of all F3SG-R in a cascade connection is 140 or less, its response time is 12 ms (Code A)/13 ms (Code B).

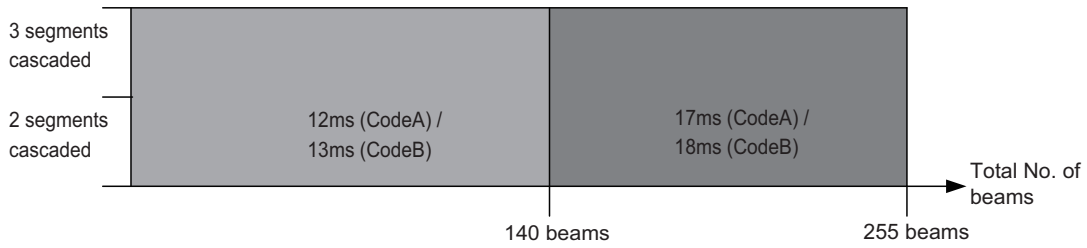
The diagram below summarizes the relation described above.



 2-3. Scan Code Selection

 4-2. Cascade Connection

Chapter 2 System Operation and Functions

2-1. Operating States	16
2-1-1. Machine Run State	16
2-1-2. Machine Stop State	16
2-2. Optical Synchronization	17
2-3. Scan Code Selection	18
2-4. PNP/NPN Selection	19
2-5. Self-Test	20
2-6. External Test	22
2-7. Lockout Reset	23
2-8. External Device Monitoring (EDM)	24
2-9. Auxiliary Output	26
2-10. Operating Range Selection	27
2-11. Lamp	28

2-1. Operating States

The operating condition of a F3SG-R system is described in terms of states. The following operating states exist for a F3SG-R system.

2-1-1. Machine Run State

The two receiver safety outputs are in the ON state, the green ON/OFF indicator is illuminated. The protected machine is allowed to operate. Pressing and releasing the rockout reset switch has no effect.

2-1-2. Machine Stop State

The two receiver safety outputs are in the OFF state, the red ON/OFF indicator is illuminated. The protected machine is not allowed to operate.

2-1-3. Lockout State

The two receiver safety outputs are in the OFF state, the red Lockout indicator is blinking, and another indicator is blinking showing an error. The Lockout state does not allow the protected machine to operate. The F3SG-R system will remain in the Lockout state until the cause of the error is corrected, regardless of power cycling or an external reset switch press and release.

2-2. Optical Synchronization

2-2-1. Overview

Synchronization is required between an emitter and a receiver for normal operation of F3SG-R. F3SG-R uses a specific beam for Synchronization. The beam is hereinafter called synchronization beam.

Depending on sensor configuration, the synchronization beam is either of the followings:

- One segment system: End beams (Top or Bottom beam)
- Cascaded system: End beams (Top or Bottom beam) of the primary sensor

For an emitter and a receiver to synchronize, at least one synchronization beam must be unblocked.

The synchronization process is performed when:

- (1) The power is turned on for an emitter and a receiver
- (2) All beams of the primary sensor are blocked and then unblocked
- (3) Synchronization is lost due to an error such as noise and ambient light

■ Conditions to establish synchronization

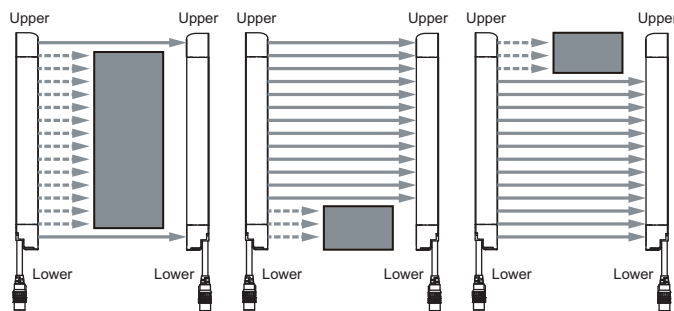

■ Conditions to fail synchronization

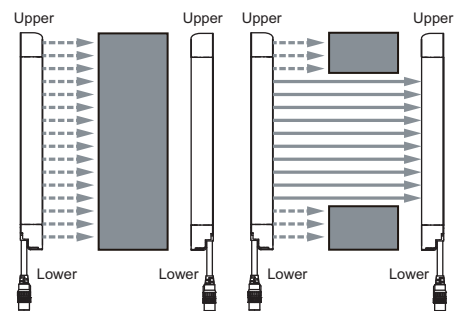

The sensor can maintain the synchronization in other cases than those described above and it is not necessary to keep the synchronization beam unblocked all the time.

CHECK!

■ Response time of “OFF (Synchronized) → ON” and “OFF (Not synchronized) → ON”

Response time of “OFF (Synchronized) → ON” is the response time from when the F3SG-R is in the OFF state and the emitter and receiver are synchronized to when the F3SG-R is turned to the ON state.

Response time of “OFF (Not synchronized) → ON” is the response time from when the F3SG-R is in the OFF state and the emitter and receiver are not synchronized to when the F3SG-R is turned to the ON state. This response time is longer since the F3SG-R evaluates if it is blocked or unblocked, after the synchronization is established.

2-3. Scan Code Selection

2-3-1. Overview

The F3SG-R has two scan codes (Code A and Code B). These scan codes have different internal processing time. The use of different scan codes allows for placement of systems in close proximity and in line with each other and minimize mutual interference.

The response time for Code A is 1 ms shorter than that for Code B.



1-6-1. List of Models/Response Time/Current Consumption/Weight for more information on the response time.



Refer to 4-1-4. Mutual Interference Prevention for how to mitigate mutual interference.

2-3-2. Factory Default Setting

The factory default setting is Code A.



Both the emitter and receiver units must be set to the same code.

CHECK!

2-3-3. Setting with DIP Switch

The user can select the scan code from Code A or Code B by the DIP Switch.



Refer to Chapter 3 Setting with DIP Switch for more information on setting this function by the DIP Switch.

2-4. PNP/NPN Selection

2-4-1. Overview

The F3SG-R offers PNP/NPN selection for the user to select the polarity of the inputs and outputs of the receiver between PNP and NPN.

When the system is set to the NPN type, the “NPN” indicator is illuminated.

2-4-2. Factory Default Setting

The factory default setting is PNP type.

2-4-3. Setting with DIP Switch

The user can select the type from PNP or NPN by the DIP Switch.

 Refer to *Chapter 3 Setting with DIP Switch* for more information on setting this function by the DIP Switch.

2-5. Self-Test

2-5-1. Overview

The F3SG-R performs the Self-Test when power is turned ON (within 2 seconds) to check for errors. Also, it regularly performs the Self-Test (within a response time) while operating.

This function cannot be cancelled.

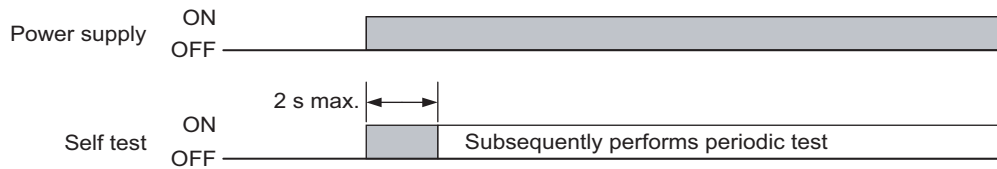

If an error is found in the Self-Test, the F3SG-R enters the Lockout state, keeps the safety output in the OFF state, and indicates the error at the same time.

2-5-1-1. Self-Test details

The Self-Test detects such error as described below.

Emitter

- Failure of emitter unit or circuit
- CPU failure
- Memory failure
- Failure of DIP Switch

Receiver

- Abnormal external power supply voltage
- Failure of internal power supply circuit
- Failure of receiver unit or detection circuit
- CPU failure
- Memory failure
- Failure of safety output circuit
- Disconnected or short-circuited cable
- Failure of DIP Switch

2-5-1-2. Waveform of safety outputs

When the safety outputs are in the ON state, they are cyclically turned OFF as shown below to test the output circuit. When this OFF signal is fed back, the output circuit is diagnosed as normal. If the output signal does not include an OFF pulse signal due to short-circuit, etc, the receiver diagnoses a failure in the output circuit or wiring, and it enters the Lockout state.

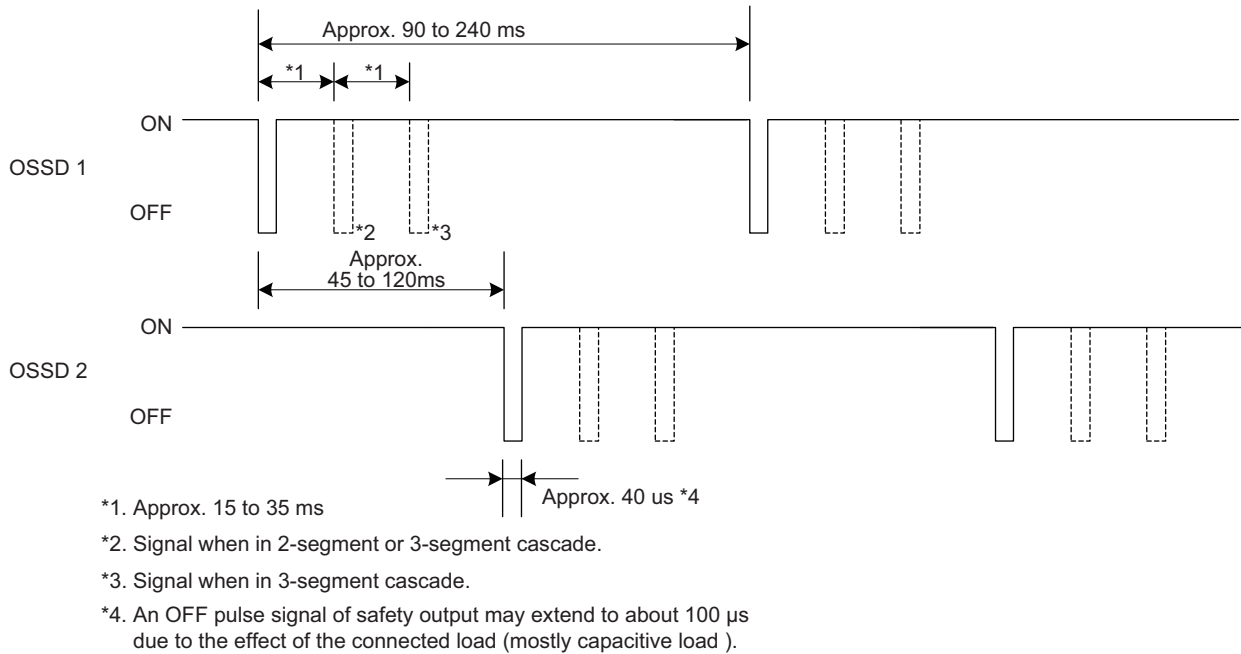

2-6. External Test

2-6-1. Overview

This function stops the emission using an external signal. It can be used to verify that a safety system should properly stop (safety output turns OFF) when F3SG-RA is blocked.

To stop the emission, apply the following voltage to the emitter's TEST input line according to the DIP switch settings of the emitter.



When muting, safety output is kept ON even if the emission is stopped.

CHECK!

DIP Switch settings (Position 4 on Emitter)	24 V Inactive	0 V Inactive
Input voltage	0 V or open	24 V or open

<Basic wiring diagram>

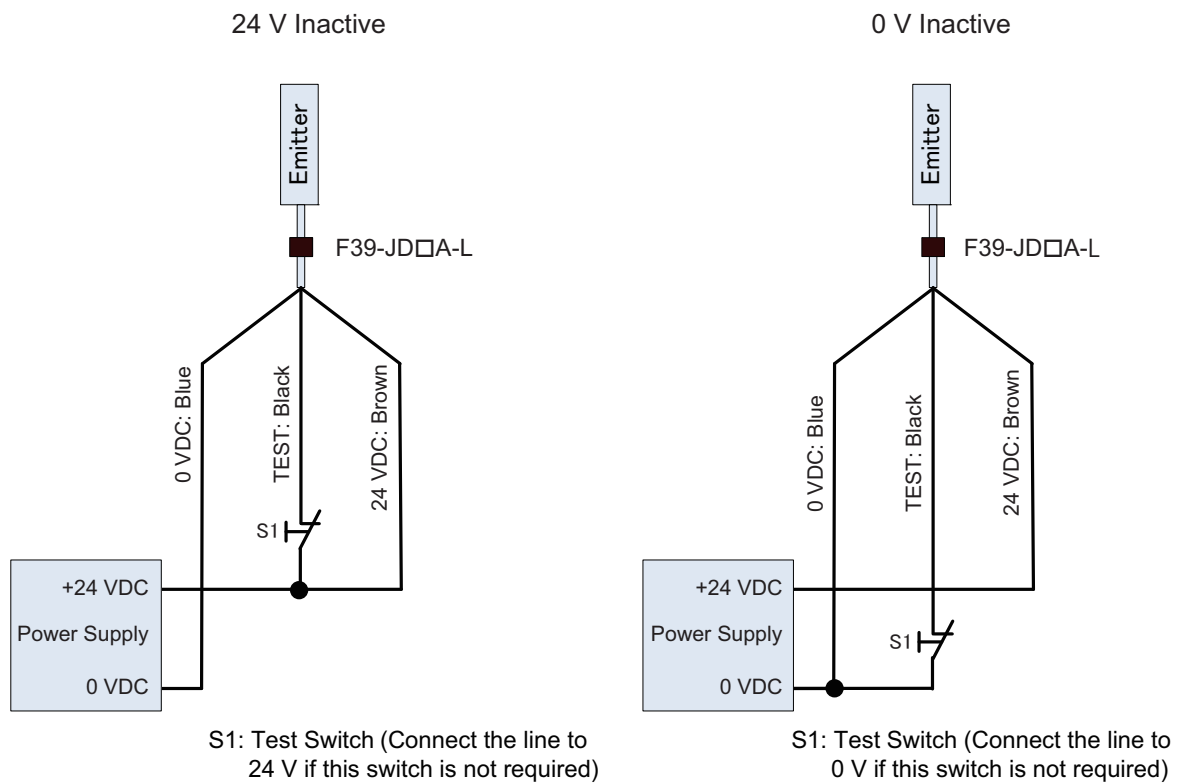

<Timing chart>

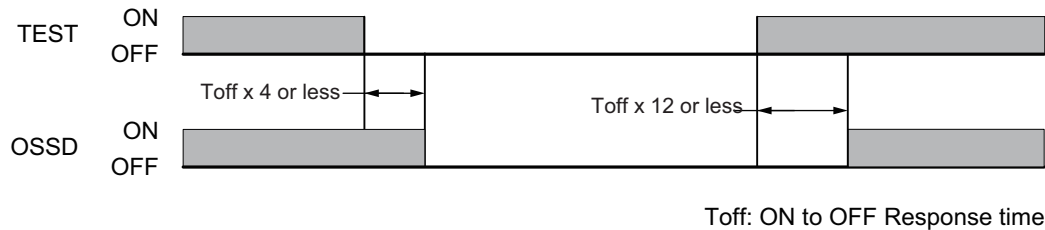

2-6-2. Factory Default Setting

The factory default setting is 24 V Inactive.

2-6-3. Setting with DIP Switch

The user can select the setting from 24 V Inactive or 0 V Inactive by the DIP Switch.



Refer to *Chapter 3 Setting with DIP Switch* for more information on setting this function by the DIP Switch.

2-7. Lockout Reset

2-7-1. Overview

When the cause of the lockout is removed, you can release the Lockout state of the F3SG-R by using either of the following methods.

- Cycle the power back ON
- Reset input

<Basic wiring diagram>

External Device Monitoring disabled

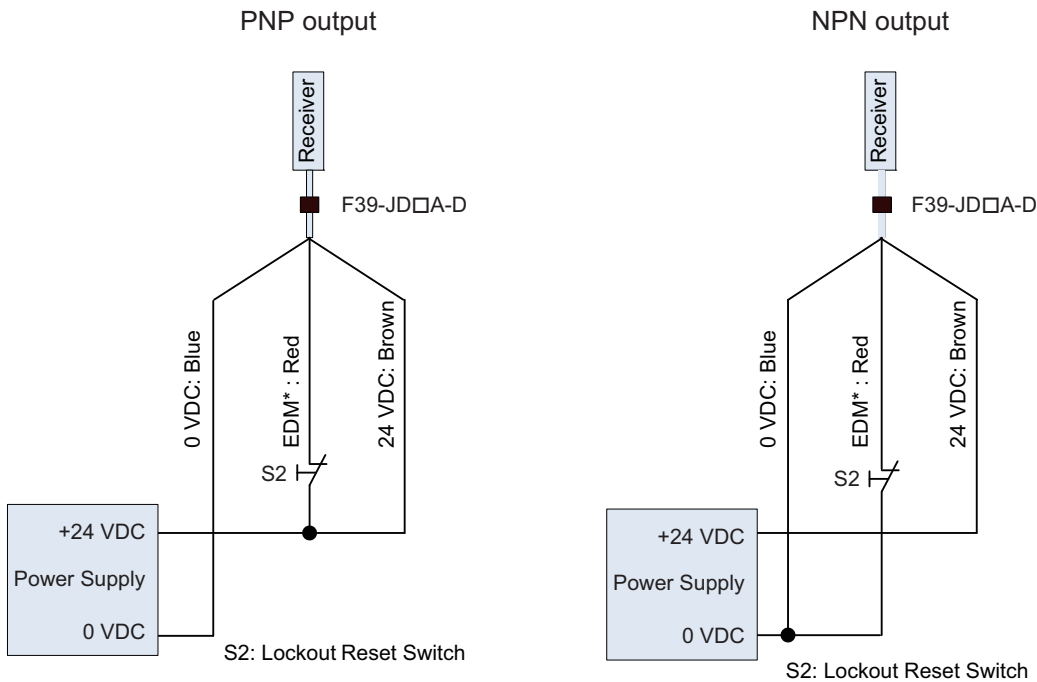

* Also used as Lockout Reset input line.

<Timing chart>

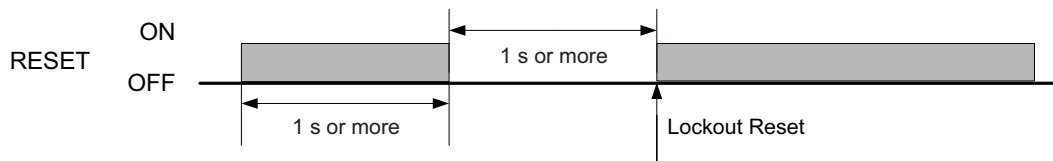

The table below shows the relation between the ON/OFF states and external lines.

Input	External Connection	
	PNP	NPN
ON	$V_s - 3\text{ V}$ to V_s	0 to 3 V
OFF	0 V to $1/2 V_s$, or open	$1/2 V_s$ to V_s , or open

2-8. External Device Monitoring (EDM)

2-8-1. Overview

This function monitors if external relays (or contactors) operate normally to detect malfunctions, such as welding, in the external relays. When the N.C. contact of the external relays is open before the safety outputs switch from OFF to ON, the safety outputs remain in the OFF state. When the N.C. contact is not open within the allowable delay time after the safety outputs switch from OFF to ON, the F3SG-R enters the Lockout state.

Wiring

Perform wiring so that the specified voltage is applied to the EDM input line via the N.C. contact of the external relays. Refer to the table below for the specified voltage.

The external relays or contactors must have the direct opening mechanism or be force-guided ones.

PNP/NPN	Voltage
PNP	Vs-3 V to Vs
NPN	0 V to 3 V

<Basic wiring diagram>

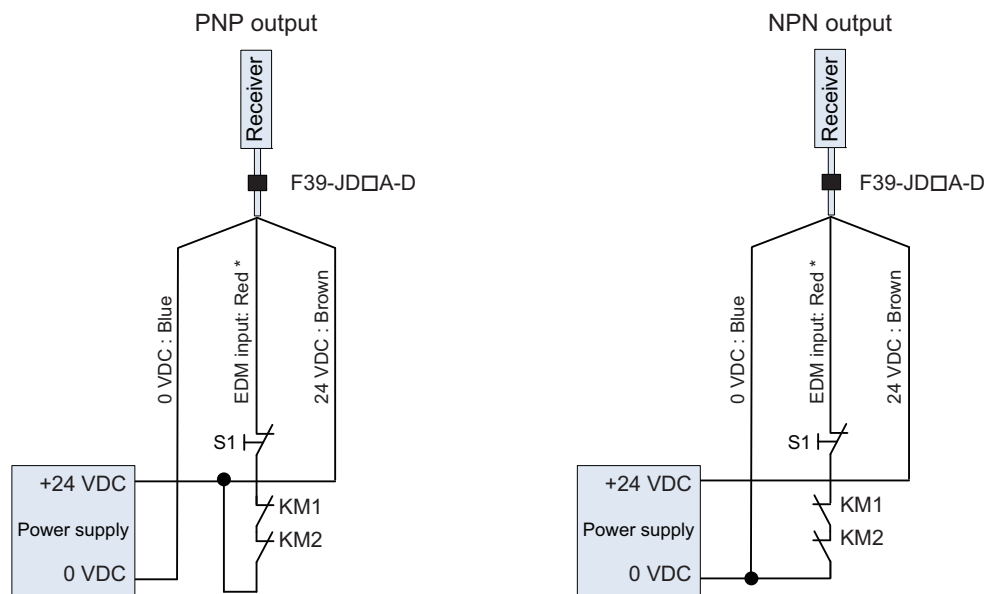

S1: Lockout Reset Switch (When the switch is not required, connect the EDM input to 24V (PNP) via the external relay (KM1, KM2) (N.C. contact) or 0V (NPN).

KM1, KM2: External device

<Timing chart>

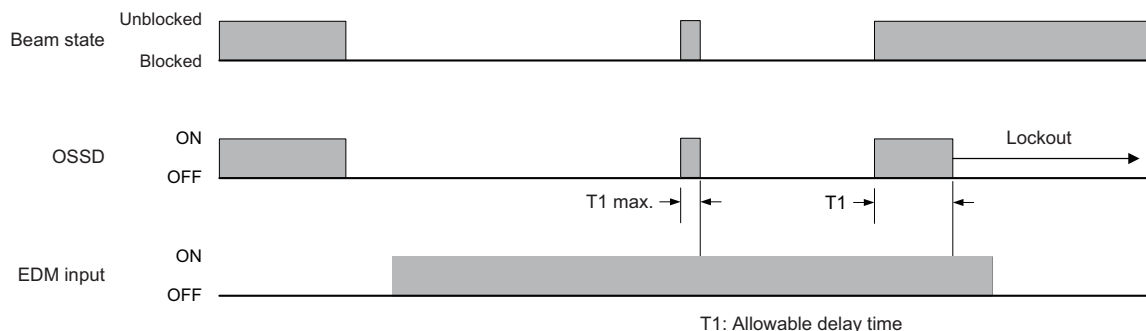

2-8-2. Factory Default Setting

The default setting is EDM Disable.

2-8-3. Setting with DIP Switch

The user can select the setting from EDM Enabled or Disabled by the DIP Switch. When it is enabled, the allowable delay time is 0.3 s.



After making the setting, make sure to perform the wiring so that the specified voltage is supplied into the EDM of the receiver without passing through the N.C. contacts of the external relays, and confirm the F3SG-RA enters the Lockout state.

CHECK!



Refer to *Chapter 3 Setting with DIP Switch* for more information on setting this function by the DIP Switch.

2-9. Auxiliary Output



WARNING

Do not use the auxiliary output for safety applications.
Failure to do so may result in serious injury when the F3SG-R fails.



2-9-1. Overview

The auxiliary output is used to monitor the status of F3SG-R. This output can be connected to a device such as an indication lamp, programmable controller, etc.

Usage Example:

- Indicate that a machine is stopped (Safety outputs are in the OFF state)

<Basic wiring diagram>

Shown below are hard wirings for PNP and NPN types, respectively.

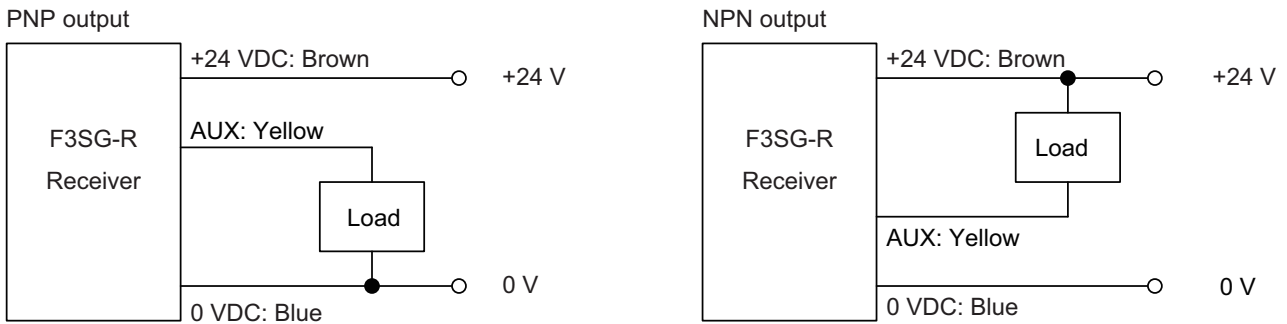

The load current of the auxiliary output is 100 mA max.

CHECK!

<Timing chart>.

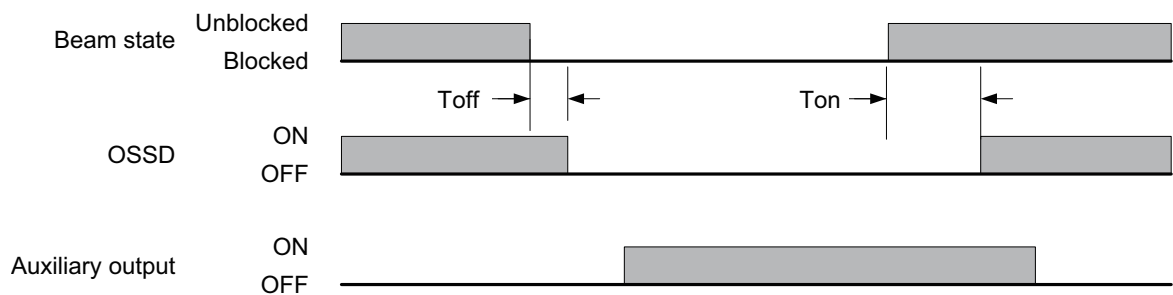

Ton: Response time OFF to ON
Toff: Response time ON to OFF

2-10. Operating Range Selection

2-10-1. Overview

The Operating Range Selection function can change the operating range by changing emission light intensity.

The following two modes in the table below are available for operating range.

Mode	Operating Range
Short Mode	0.3 m~5.0 m
Long Mode	0.3 m~17.0 m

■ Example

- To set shorter operating range to prevent the F3SG-R from affecting other photoelectric sensors
- To set shorter operating range to prevent mutual interference in a close area

■ F3SG-R LED indicator status

When the Operating Range Selection is configured as LONG Mode, the LONG indicator turns on.

2-10-2. Factory Default Setting

In the factory default setting, the Operating Range Selection is configured as Long Mode.

2-10-3. Setting with DIP Switch

The user can select the mode of Operating Range Selection by the DIP Switch.

 Refer to *Chapter 3 Setting with DIP Switch* for more information on setting this function by the DIP Switch.

2-11. Lamp

2-11-1. Overview

A lamp (F39-LP and F39-BTLP, sold separately) can be connected to a receiver and turned ON based on the operation of F3SG-R. When there are several illumination conditions, the priority of the colors to illuminate or blink is red > orange > green.



Refer to the instruction sheet of the Lamp for more information.



The lamp is not intended to be used for the emitter. Do not connect the lamp to the emitter.

■ Lamp output pattern

Lamp output	Function	Description
Red (Priority 1)	Output operation mode	Inverted signal of safety output information
	Output pattern	ON
Orange (Priority 2)	Output operation mode	Inverted signal of stable-state information
	Output pattern	ON 1 time
Green (Priority 3)	Output operation mode	Safety output information
	Output pattern	ON

■ Output pattern chart

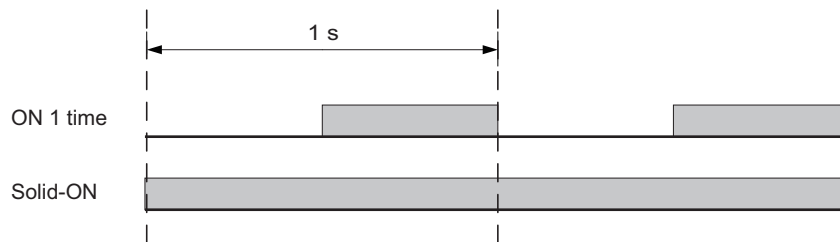

2-11-2. Setting with DIP Switch

The user cannot make any changes to this function by the DIP Switch.

Chapter 3 Setting with DIP Switch

3-1. List of Features Configurable by DIP Switch	32
3-2. DIP Switch	33
3-2-1. DIP Switch on Receiver	34
3-2-2. DIP Switch on Emitter	34

3-1. List of Features Configurable by DIP Switch

The following functions are configurable by the DIP Switch.

Feature	page
Scan Code Selection	p.18
PNP/NPN Selection	p.19
External Test	p.22
External Device Monitoring (EDM)	p.24
Operating Range Selection	p.27

3-2. DIP Switch

⚠ DANGER

Make sure to test the operation of the F3SG-R after setting with DIP Switch to verify that the F3SG-R operates as intended. Make sure to stop the machine until the test is complete. Unintended settings may cause a person to go undetected, resulting in serious injury or death.



This product has DIP Switches to configure functions. Configure functions with the DIP Switches before installing F3SG-R in your site. To set DIP Switches, turn the power of the F3SG-R off and open the cover as shown below. When the setting the DIP Switch is complete, close the cover and turn the power of the F3SG-R on.

Cascaded sensors is operated based on the DIP Switches setting of the primary sensor. The DIP Switch setting of a secondary sensor does not affect the operation.

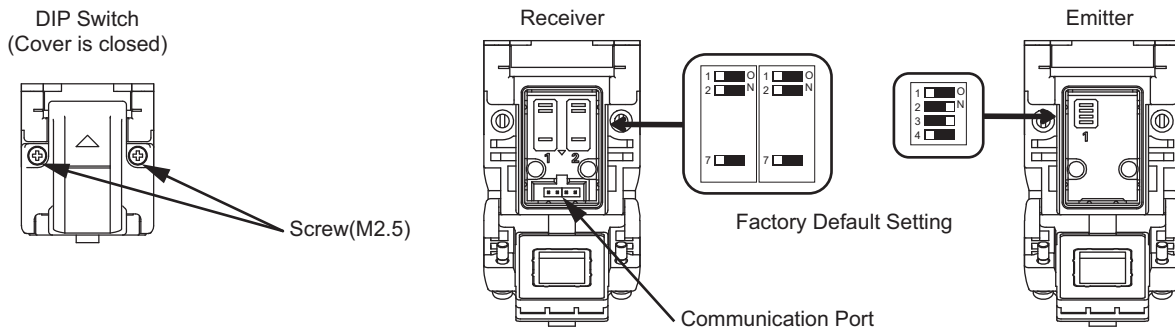

💡 When attaching the cover, tightly fasten the screws (M2.5, recommended torque: 0.35N.m). Failure to do so may cause the cover to come loose, leading to deterioration of the protective functions.

CHECK!

💡 The Spatter Protection Cover (F39-HGA, sold separately) extends over the DIP Switch cover of the F3SG-RA. Be sure to use the Spatter Protection Cover only after all required settings are made to the DIP Switch.

CHECK!

The following functional settings are available by DIP Switches and Push Switch.

Receiver	Position	Function	Emitter	Position	Function
	1	Scan Code		1	Scan Code
	2	External Device Monitoring (EDM)		2	Operating Range Selection
	7	PNP/NPN Selection		3	
				4	External Test

💡 Operate the DIP Switch before turning the power of the F3SG-R on.
 If the DIP Switch is operated during operation of the F3SG-R, the F3SG-R transitions to lockout.
⚠ A change of the DIP Switch setting is activated upon power-on or lockout reset.
 Note that do not use any tool which may damage F3SG-R's body when operating the DIP Switch.

CHECK!

3-2-1. DIP Switch on Receiver

The following functional settings are available by DIP Switches on the receiver. A receiver has two DIP Switches, both of which must be configured based on the table below. For functional details, see respective chapter in the Functional Details column.



If the settings of two DIP Switches are different, when the power is turned on, F3SG-R transitions to lockout.

: Indicates a switch position.

Position	Function	Setting		Description	Functional Details
		DIP-SW1	DIP-SW2		
1	Scan Code	1 <input type="checkbox"/> ON	1 <input type="checkbox"/> ON	Scan Code A (factory default setting)	2-3
		1 <input type="checkbox"/> ON	1 <input type="checkbox"/> ON	Scan Code B	2-3
2	External Device Monitoring (EDM)	2 <input type="checkbox"/> ON	2 <input type="checkbox"/> ON	External Device Monitoring (EDM) Disabled (factory default setting)	2-8
		2 <input type="checkbox"/> ON	2 <input type="checkbox"/> ON	External Device Monitoring (EDM) Enabled	2-8
7	PNP/NPN Selection	7 <input type="checkbox"/> ON	7 <input type="checkbox"/> ON	PNP (factory default setting)	2-4
		7 <input type="checkbox"/> ON	7 <input type="checkbox"/> ON	NPN	2-4

3-2-2. DIP Switch on Emitter

The following functional settings are available by DIP Switches on the emitter. For functional details, see respective chapter in the Functional Details column.

: Indicates a switch position.

Position	Function	Setting	Description	Functional Details
1	Scan Code	1 <input type="checkbox"/> ON	Scan Code A (factory default setting)	2-3
		1 <input type="checkbox"/> ON	Scan Code B	2-3
2, 3	Operating Range Selection	2 <input type="checkbox"/> ON 3 <input type="checkbox"/> ON	Short Mode	2-10
		2 <input type="checkbox"/> ON 3 <input type="checkbox"/> ON	Setting Inhibited	-
		2 <input type="checkbox"/> ON 3 <input type="checkbox"/> ON	Setting Inhibited	-
		2 <input type="checkbox"/> ON 3 <input type="checkbox"/> ON	Long Mode (factory default setting)	2-10
4	External Test	4 <input type="checkbox"/> ON	24 V Inactive (factory default setting)	2-6
		4 <input type="checkbox"/> ON	0 V Inactive	2-6



If the power is turned on while the switch is configured as Setting Inhibited, F3SG-R transitions to lockout.

Chapter 4 Wiring/Installation

4-1. Installation Considerations	37
4-1-1. Detection Zone and Approach	37
4-1-2. Safety Distance	38
4-1-3. Distance from Reflective Surfaces	42
4-1-4. Mutual Interference Prevention	43
4-2. Cascade Connection	44
4-2-1. Overview	44
4-2-2. Connection Procedure	46
4-3. Dimensions	47
4-3-1. Mounted with Standard Fixed Brackets (F39-LGF)	47
4-3-1-1. External Dimensions	47
4-3-1-2. Standard Fixed Bracket	49
4-3-2. Mounted with Standard Adjustable Brackets (F39-LGA)	50
4-3-2-1. External Dimensions	50
4-3-2-2. Standard Adjustable Bracket	52
4-3-3. Mounted with Top/Bottom Adjustable Brackets (F39-LGTB) and Standard Adjustable Brackets (F39-LGA)	53
4-3-3-1. External Dimensions	53
4-3-3-2. Top/Bottom Adjustable Bracket (F39-LGTB)	58
4-3-3-3. Top/Bottom Adjustable Bracket (F39-LGTB-1)	59
4-4. Mounting	60
4-4-1. Mounting Method	60
4-4-2. Number of Brackets Required	60
4-4-3. Mounting Procedure	61
4-4-3-1. Mounting with Standard Fixed Brackets (F39-LGF)	61
4-4-3-2. Mounting with Standard Adjustable Brackets (F39-LGA)	62

4-4-3-3. Mounting with Top/Bottom Adjustable Brackets (F39-LGTB)	65
4-4-4. Beam Alignment Procedure	68
4-5. Wiring	69
4-5-1. Wiring Precautions	69
4-5-2. Power Supply Unit	70
4-5-3. Cable Connections	71
4-5-3-1. Single-Ended Cable	71
4-5-3-2. Double-Ended Cable	72
4-5-3-3. Cascading Cable	74
4-5-3-4. Extending Cable Length with Commercially Available Cable	75
4-5-4. Functional Earth Connection	76

4-1. Installation Considerations

4-1-1. Detection Zone and Approach

⚠ WARNING

Install a protective structure so that the hazardous part of a machine can only be reached by passing through the sensor's detection zone. If access to the hazardous part by reaching over the detection zone of a vertically mounted F3SG-R cannot be excluded, the height of the detection zone and the safety distance shall be determined in consideration of such a risk. Install the sensors so that part of the person is always present in the detection zone when working in a machine's hazardous zones. If a person is able to step into the hazardous zone of a machine and remain behind the F3SG-R's detection zone, configure the system with Restart Interlock function. Failure to do so may result in serious injury due to unexpected startup.



Do not use this sensor for machines that cannot be stopped by electrical control. For example, do not use it for a pressing machine that uses a full-rotation clutch. Otherwise, the machine may not stop before a person reaches the hazardous part, resulting in serious injury.



To use the F3SG-R in PSDI mode (Reinitiation of cyclic operation by the protective equipment), you must configure an appropriate circuit between the F3SG-R and the machine. For details about PSDI, refer to OSHA1910.217, IEC61496-1, and other relevant standards and regulations.



Install the reset switch in a location that provides a clear view of the entire hazardous zone and where it cannot be activated from within the hazardous zone.



Do not use the F3SG-R in environments where flammable or explosive gases are present. Doing so may cause an explosion.



The F3SG-R cannot protect a person from an object flying from a hazardous zone. Install protective cover(s) or fence(s).



Correct installation

The hazardous zone of a machine can be reached only by passing through the sensor's detection zone.



While working, a person is inside the sensor's detection zone.



Safety distance reflects the possible access to the hazardous zone by reaching over the detection zone.

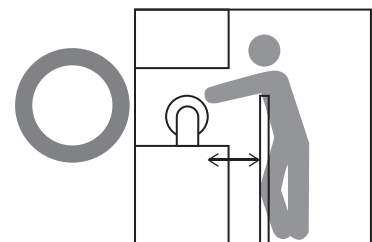

Incorrect installation

It is possible to reach the hazardous zone of a machine without passing through the sensor's detection zone.



A person is between the sensor's detection zone and the hazardous zone of a machine.



It is possible to access the hazardous zone by reaching over the detection zone.



4-1-2. Safety Distance

The safety distance is the distance that must be set between the F3SG-R and a machine's hazardous part to stop the hazardous part before a person or object reaches it. The safety distance varies according to the standards of each country and the individual specifications of each machine. Always refer to the relevant standards.

WARNING

Make sure to secure the safety distance (S) between the F3SG-R and the hazardous part. Otherwise, the machine may not stop before a person reaches the hazardous part, resulting in serious injury.



CHECK! The response time of a machine is the time period from when the machine receives a stop signal to when the machine's hazardous part stops. Measure the response time on the actual system. Also, periodically check that the response time of the machine has not changed.

4-1-2-1. Safety Distance Formulas according to ISO 13855/EN ISO 13855

Detection Zone Orthogonal to Direction of Approach

$S = K \times T + C$. . . Formula (1)

- S: Safety distance
- K: Approach speed to the detection zone
- T: Total response time of the machine and F3SG-R
- C: Additional distance calculated by the detection capability (or object resolution) of the F3SG-R

Calculation Example for Systems with a Resolution of = 25 mm

Use $K = 2,000 \text{ mm/s}$ and $C = 8 \times (d - 14 \text{ mm})$ in formula (1) for the calculation.

$S = 2,000 \text{ mm/s} \times (T_m + T_s) + 8 \times (d - 14 \text{ mm})$

- S = Safety distance (mm)
- T_m = Machine's response time (s)
- T_s = Response time of the F3SG-R from ON to OFF (s)
- d = Detection capability (or object resolution) of the F3SG-R (mm)

[Calculation example]

When $T_m = 0.05 \text{ s}$, $T_s = 0.08 \text{ s}$, and $d = 25 \text{ mm}$:

$S = 2,000 \text{ mm/s} \times (0.05 \text{ s} + 0.08 \text{ s}) + 8 \times (25 \text{ mm} - 14 \text{ mm})$
 $= 204 \text{ mm}$. . . Formula (2)

If the result $< 100 \text{ mm}$, use $S = 100 \text{ mm}$.

If the result exceeds 500 mm , use the following expression where $K = 1,600 \text{ mm/s}$.

$S = 1,600 \text{ mm/s} \times (T_m + T_s) + 8 \times (d - 14 \text{ mm})$. . . Formula (3)

If the result of this formula (3) $< 500 \text{ mm}$, use $S = 500 \text{ mm}$.

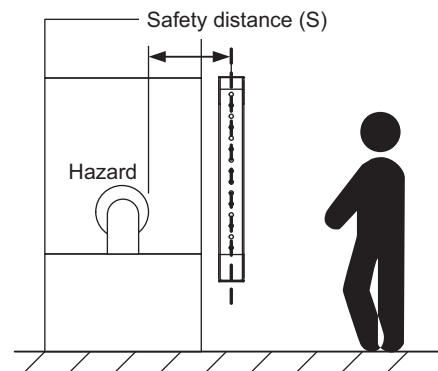

Possible Circumventing by Reaching Over the Detection Zone

If access to the hazardous zone by reaching over the detection zone of vertically mounted F3SG-R cannot be excluded, the height and the safety distance, S, of the F3SG-R shall be determined. S shall be determined by comparison of the calculated values in *Detection Zone Orthogonal to Direction of Approach*. The greater value resulting from this comparison shall be applied.

$S=(K \times T) + Cro \dots$ Formula (4)

- S: Safety distance
- K: Approach speed to the detection zone
- T: Total response time of the machine and FSG-R
- Cro: Approach distance based on the distance which personnel can move towards the hazardous zone of a machine by reaching over the detection zone. The distance is determined in the table below based on the height of the hazardous zone, a, and the height of the upper edge of the detection zone, b.

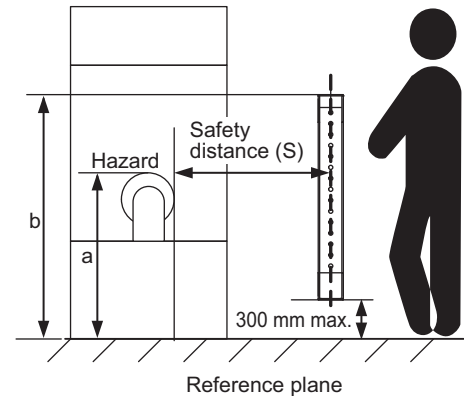

Note: Lower edge of the detection zone above 300 mm in relation to the reference plane does not offer sufficient protection against crawling below.

First, use $K = 2,000 \text{ mm/s}$ in formula (4) for the calculation. If the result of this calculation is less than 100 mm, use $S = 100 \text{ mm}$.

If the result exceeds 500 mm, use $K = 1,600 \text{ mm/s}$ to recalculate it. If the result of the recalculation is less than 500 mm, use $S = 500 \text{ mm}$.

Height of hazardous zone, a	Height of upper edge of detection zone, b											
	900	1000	1100	1200	1300	1400	1600	1800	2000	2200	2400	2600
	Additional distance to hazardous zone, Cro											
2600	0	0	0	0	0	0	0	0	0	0	0	0
2500	400	400	350	300	300	300	300	300	250	150	100	0
2400	550	550	550	500	450	450	400	400	300	250	100	0
2200	800	750	750	700	650	650	600	550	400	250	0	0
2000	950	950	850	850	800	750	700	550	400	0	0	0
1800	1100	1100	950	950	850	800	750	550	0	0	0	0
1600	1150	1150	1100	1000	900	850	750	450	0	0	0	0
1400	1200	1200	1100	1000	900	850	650	0	0	0	0	0
1200	1200	1200	1100	1000	850	800	0	0	0	0	0	0
1000	1200	1150	1050	950	750	700	0	0	0	0	0	0
800	1150	1050	950	800	500	450	0	0	0	0	0	0
600	1050	950	750	550	0	0	0	0	0	0	0	0
400	900	700	0	0	0	0	0	0	0	0	0	0
200	600	0	0	0	0	0	0	0	0	0	0	0
0	0	0	0	0	0	0	0	0	0	0	0	0

Note 1. Upper edge of the detection zone below 900 mm is not included since they do not offer sufficient protection against circumventing or stepping over.

Note 2. When determining the values of this table, it shall not be interpolated. If the known values a, b or Cro are between two values of this table, the greater safety distance shall be used.

[Calculation example]

- T: $T_m + T_s$ (s)
- T_m : Machine's response time (s)
- T_s : Response time of the F3SG-R from ON to OFF (s)

- a: Height of machine hazardous zone (mm)
- b: Height of upper edge of detection zone (mm)

When $T_m = 0.05$ s, $T_s = 0.008$ s, $a = 1,400$ mm, $b = 1,500$ mm:

From the table above, $C_{ro} = 850$ mm. Since b is between 1,400 mm and 1,600 mm, $b = 1,400$ mm which has the greater C_{ro} value, shall be used.

$$S = 2,000 \text{ mm/s} \times (0.05 \text{ s} + 0.008 \text{ s}) + 850 \text{ mm} \\ = 966 \text{ mm}$$

Since 966 mm is greater than 500 mm, use $K = 1,600$ mm/s and recalculate it.

$$S = 1,600 \text{ m/s} \times (0.05 \text{ s} + 0.008 \text{ s}) + 850 \text{ mm} \\ = 942.8 \text{ mm}$$

Since $S = 942.8$ mm is greater than $S = 116$ mm calculated by the calculation example of *Detection Zone Orthogonal to Direction of Approach*, the required safety distance S is 942.9 mm.

 Refer to *Detection Zone Orthogonal to Direction of Approach* under 4-1-2-1. *Safety Distance Formulas according to ISO 13855/EN ISO 13855.*

Detection Zone Parallel to Direction of Approach

Use $K = 1,600$ mm/s and $C = (1200 - 0.4 \times H)$ in formula (1) for calculation. Note that C must not be less than 850 mm.

$$S = 1,600 \text{ mm/s} \times (T_m + T_s) + 1200 - 0.4 \times H$$

- S = Safety distance (mm)
- T_m = Machine's response time (s)
- T_s = Response time of F3SG-R from ON to OFF (s)
- H = Installation height (mm)

Note that H must satisfy:

$$1000 \geq H \geq 15(d - 50 \text{ mm}) \geq 0 \text{ mm}$$

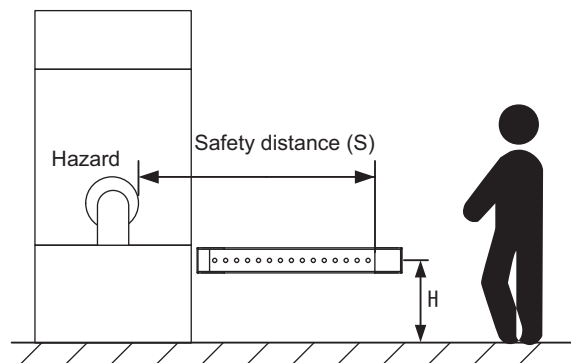

Also, you must include a hazardous condition under which a person may go through under a detection zone if H exceeds 300 mm (200 mm for other purpose than industrial use) into risk assessment.

[Calculation example]

When $T_m = 0.05$ s, $T_s = 0.08$ s, and $d = 25$ mm:

$$S = 1,600 \text{ mm/s} \times (0.05 \text{ s} + 0.08 \text{ s}) + 1200 - 0.4 \times 500 \text{ mm} \\ = 1092.8 \text{ mm}$$

4-1-2-2. Safety Distance Formulas according to ANSI B11.19

If a person approaches the detection zone of the F3SG-R orthogonally, calculate the safety distance as shown below.

$$S = K \times (T_s + T_c + T_r + T_{bm}) + D_{pf}$$

- S: Safety distance
- K: Approach speed to the detection zone (the value recommended by OSHA standard is 1,600 mm/s)

Approach speed K is not specified in the ANSI B.11.19 standard. To determine the value of K to apply, consider all factors, including the operator's physical ability.

- T_s = Machine's stopping time (s)
- T_r = Response time of the F3SG-R from ON to OFF (s)
- T_c = Machine control circuit's maximum response time required to activate its brake (s)
- T_{bm} = Additional time (s)

If a machine has a brake monitor, " T_{bm} = Brake monitor setting time - ($T_s + T_c$)". If it has no brake monitor, we recommend using 20% or more of ($T_s + T_c$) as additional time.

- D_{pf} = Additional distance

According to ANSI's formula, D_{pf} is calculated as shown below:

$D_{pf} = 3.4 \times (d - 7.0)$: Where d is the detection capability (or object resolution) of the F3SG-R (unit: mm)

[Calculation example]

When $K = 1,600$ mm/s, $T_s + T_c = 0.06$ s, brake monitor setting time = 0.1 s,

$T_r = 0.008$ s, and $d = 25$ mm:

$$T_{bm} = 0.1 - 0.06 = 0.04 \text{ s}$$

$$D_{pf} = 3.4 \times (25 - 7.0) = 61.2 \text{ mm}$$

$$S = 1,600 \times (0.06 + 0.008 + 0.04) + 61.2 = 234 \text{ mm}$$

4-1-3. Distance from Reflective Surfaces

⚠ WARNING

Install the sensor system so that it is not affected by reflective surfaces. Failure to do so may hinder detection, resulting in serious injury.



Install the sensor system at distance D or further from highly reflective surfaces such as metallic walls, floors, ceilings, or workpieces, as shown below.

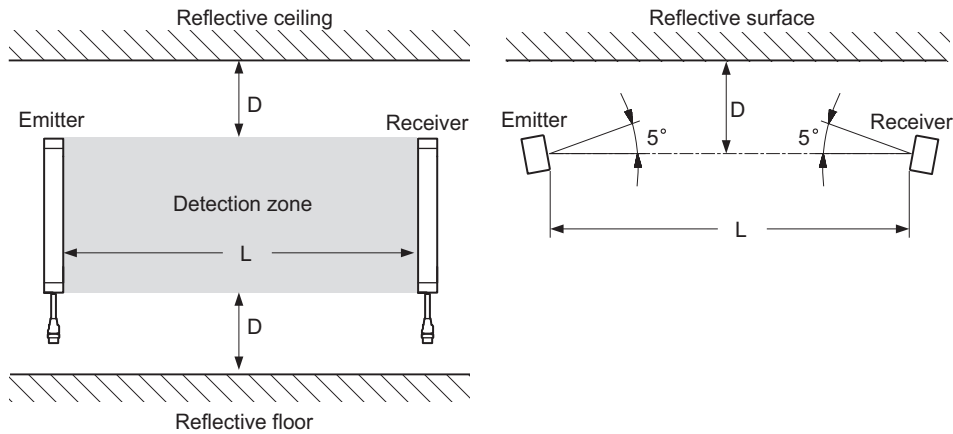

Distance between an emitter and a receiver (operating range L)	Allowable installation distance D
0.3 to less than 3 m	0.13 m
3 m or more	$L/2 \times \tan 5^\circ = L \times 0.044 \text{ m}$

4-1-4. Mutual Interference Prevention

⚠ WARNING

Do not use the sensor system with mirrors in a retro-reflective configuration. Doing so may hinder detection. It is possible to use mirrors to alter the detection zone to a 90-degree angle.



When using more than 1 set of F3SG-R in adjacent areas, the emitter of one F3SG-R may interfere with the receiver of the other, causing the safety functions to stop working properly. Install and configure them so that mutual interference does not occur.



When two or more F3SG-R systems are mounted in close proximity to each other, precautions should be taken to avoid one system interfering with another, such as by beam alignment, back-to-back configuration, physical barrier, Scan Code Selection or Operating Range Selection.

■ Example

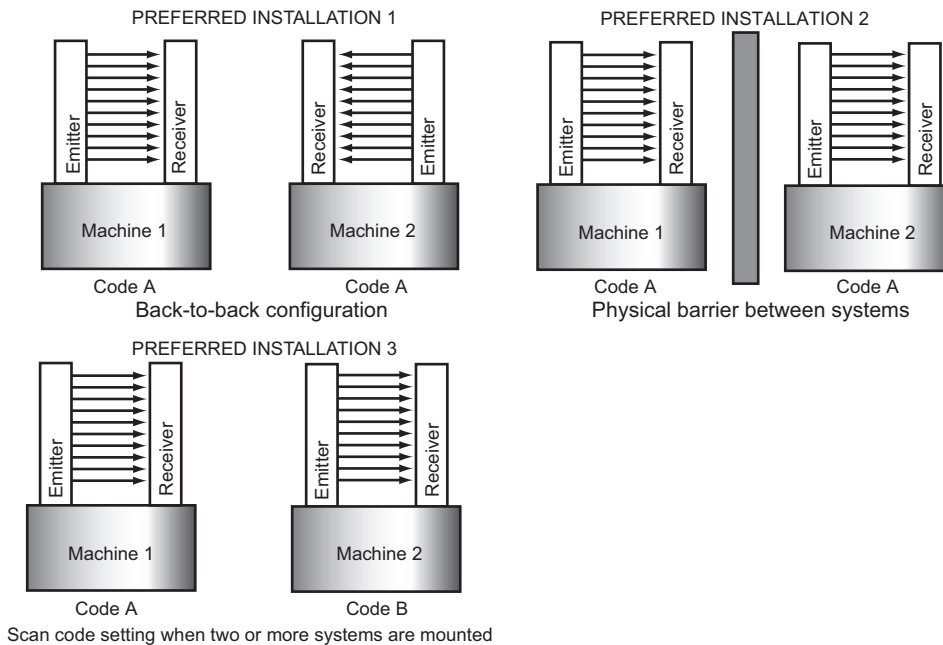

The scan code feature of the F3SG-R system allows for placement of systems in close proximity and in line with each other. The distinctive coding of the beams provide for unique operation of a system while in view of another system with a different scan code. Two unique codes are available on the F3SG-R.

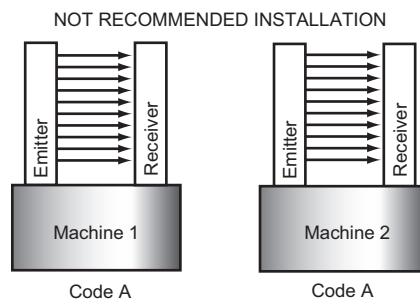

The emitter and receiver units must be set to the same scan code for the receiver to enter the Machine Run state. The scan code is selectable by the DIP Switch on the emitter and receiver units.

Refer to 2-3. *Scan Code Selection* for more information on the scan code feature.

Refer to 3-2. *DIP Switch* for more information on setting the scan code by the DIP Switch.

4-2. Cascade Connection

The F3SG-4RA□□□□-25-01TS Series can be used in cascade connection with each other.



The F3SG-R cannot be used in cascade connection with the F3SG-□RA□□□□-14 Series or the F3SG-□RA□□□□-30 Series.

CHECK!

4-2-1. Overview

Up to 3 sets of F3SG-R can be series-connected. Cascade connection allows them to be used as a safety light curtain, requiring only 1 set to be wired to a controller and preventing mutual interference. If any 1 set of series-connected F3SG-R is blocked, both of the safety outputs turn OFF.

- Number of connections: Up to 3 sets
- Total number of beams: Up to 255 beams
- Cable length between sensors: Up to 10 m

Example: Configuring an U-shaped detection zone

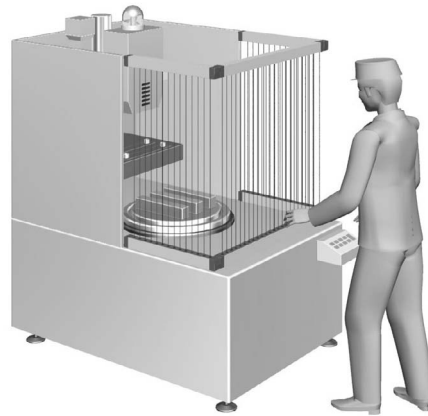

The sensor segments in a cascade connection are called as follows:

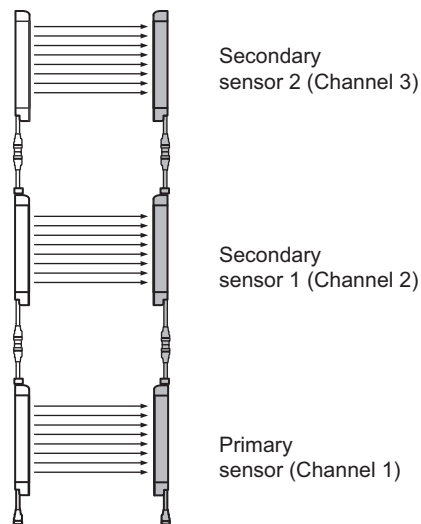

The cascaded segments operate according to the DIP Switch settings of the primary sensor. The DIP Switch settings of the primary sensor do not affect the operation.

CHECK!

Properly connect an emitter to another emitter, and a receiver to another receiver, as shown below.

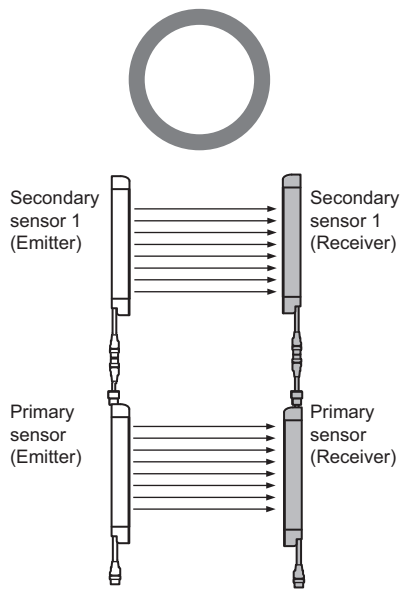

Do not series-connect an emitter and receiver. They will enter lockout state.

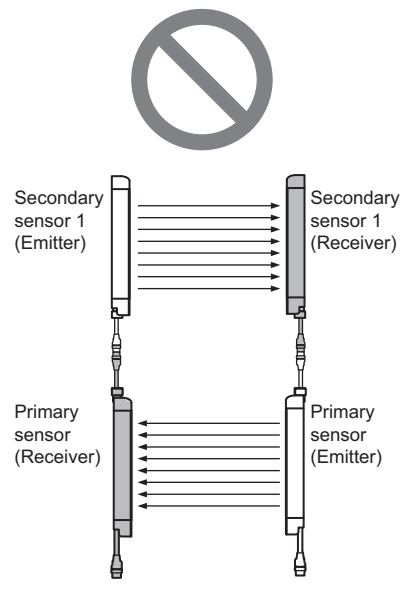

Do not face different models of emitters and receivers toward each other. They will enter lockout state or will be unable to detect objects

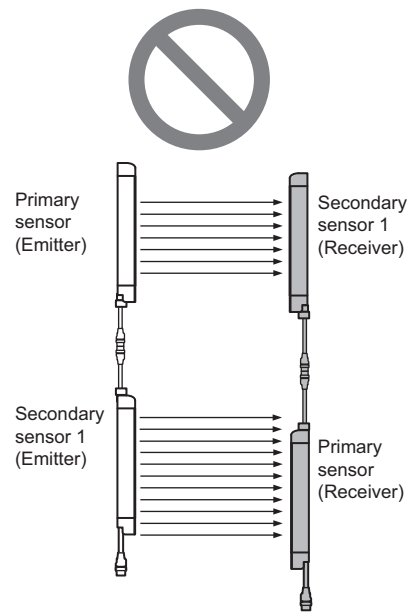

If caps and Cascading Cables are not connected properly, the F3SG-R enters lockout (when power is turned ON).

4-2-2. Connection Procedure

1. Remove the caps from the primary sensor. Loosen the screw (M3 cross-shaped) to remove the cap.
2. Connect the the the primary sensor and the secondary sensor with the F39-JGR2WTS Cascading Cable (sold separately).
3. If the length of the Cascading Cable is insufficient, connect the F39-JD□B-□ Double-Ended Cable (sold separately) between the Cascading Cable and the power cable of the secondary sensor, as required. (Cable length between sensors: 10 m max.)

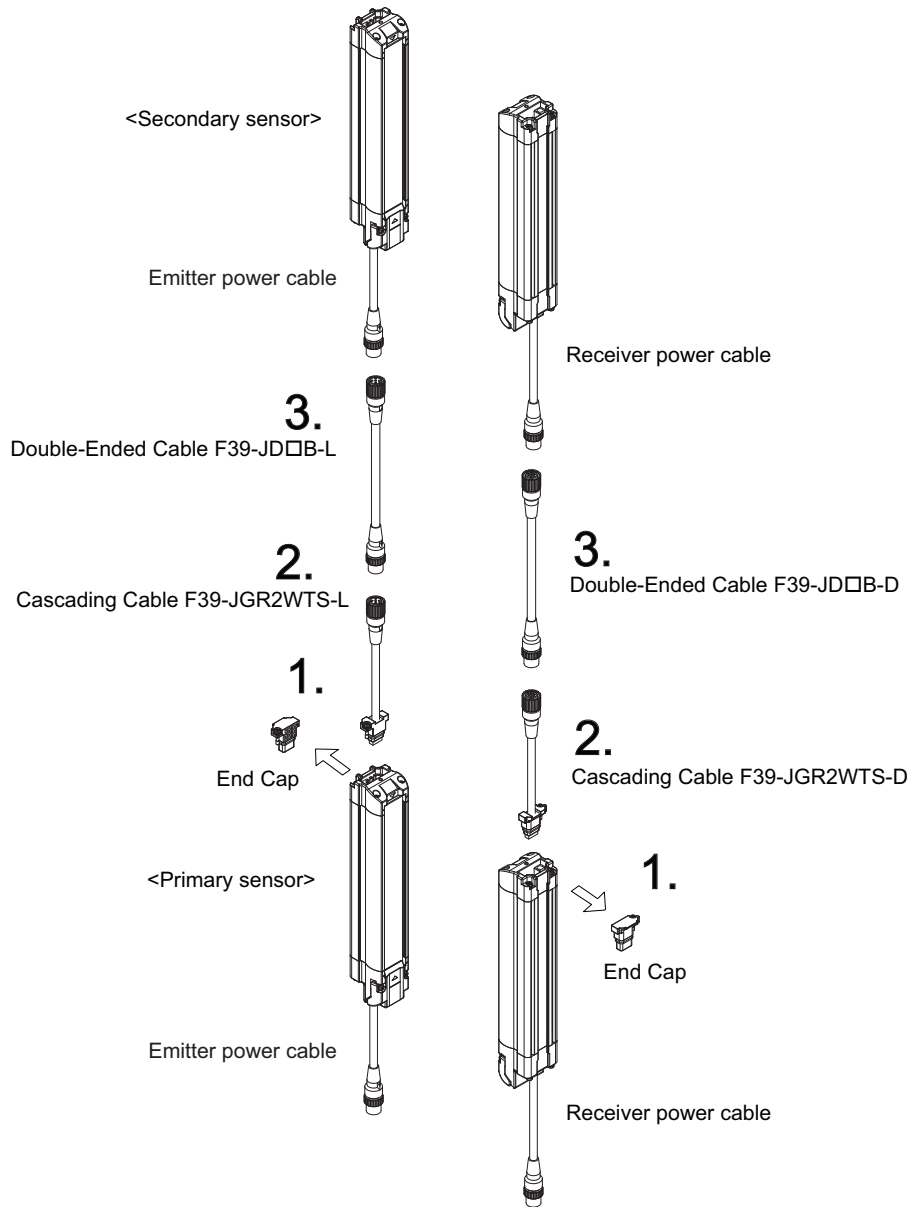

CHECK!

- When attaching a cable or cap, securely fasten the screws (M2.5, recommended torque: 0.35 N·m). Failure to do so may cause the cable/cap to come loose, leading to deterioration of the protective functions.
- Attaching/detaching of the cap and the Cascading Cable may cause misalignment of rubber grommet in the connector assembly. Press the grommet to the bottom of the connector and attach the connector to the sensor again.

4-3. Dimensions

4-3-1. Mounted with Standard Fixed Brackets (F39-LGF)

4-3-1-1. External Dimensions

■ Backside Mounting

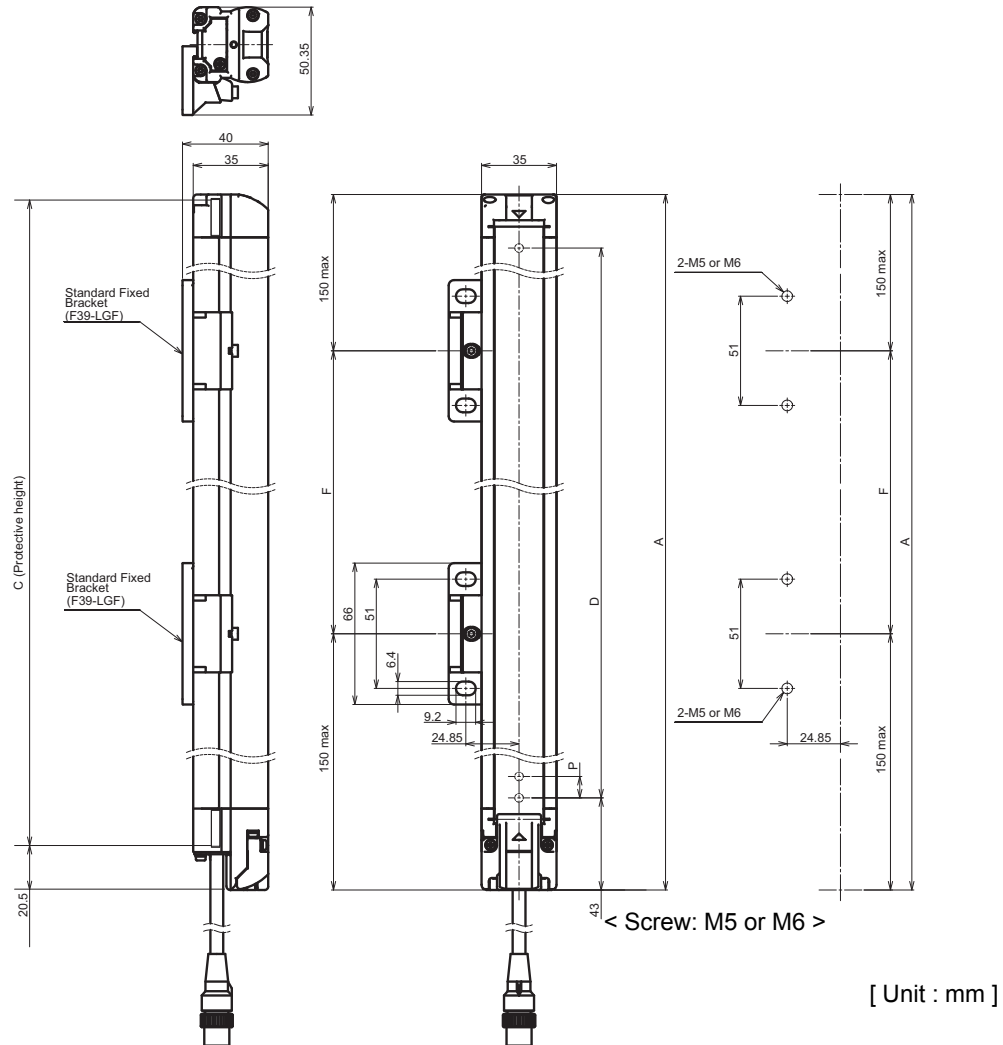

F3SG-4RA□□□□-25-01TS Series

Dimension A	C+23
Dimension C	4-digit number of the type name (Protective height)
Dimension D	C-45
Dimension P	20

Protective height (C)	Number of Standard Fixed Brackets *1	Dimension F
0185 to 1225	2 *2	1000 mm max.
1305 to 1945	3	1000 mm max.

*1. The number of brackets required to mount either one of emitter and receiver.

*2. Mounting an emitter or receiver with one bracket is possible for the models of protective height of 0185 or 0265. In this case, locate this bracket at half the Dimension A (or at the center of the sensor length).



4-4-3-1. Mounting with Standard Fixed Brackets (F39-LGF)



- Use the brackets of specified quantities and locations according to the dimensions. The other brackets than described above may not meet the specified ratings and performance.

CHECK!

- When you use the sensor in a situation where the sensor is under a load, increase the number of the brackets used.

- The Standard Fixed Bracket does not allow beam alignment.

■ Side Mounting

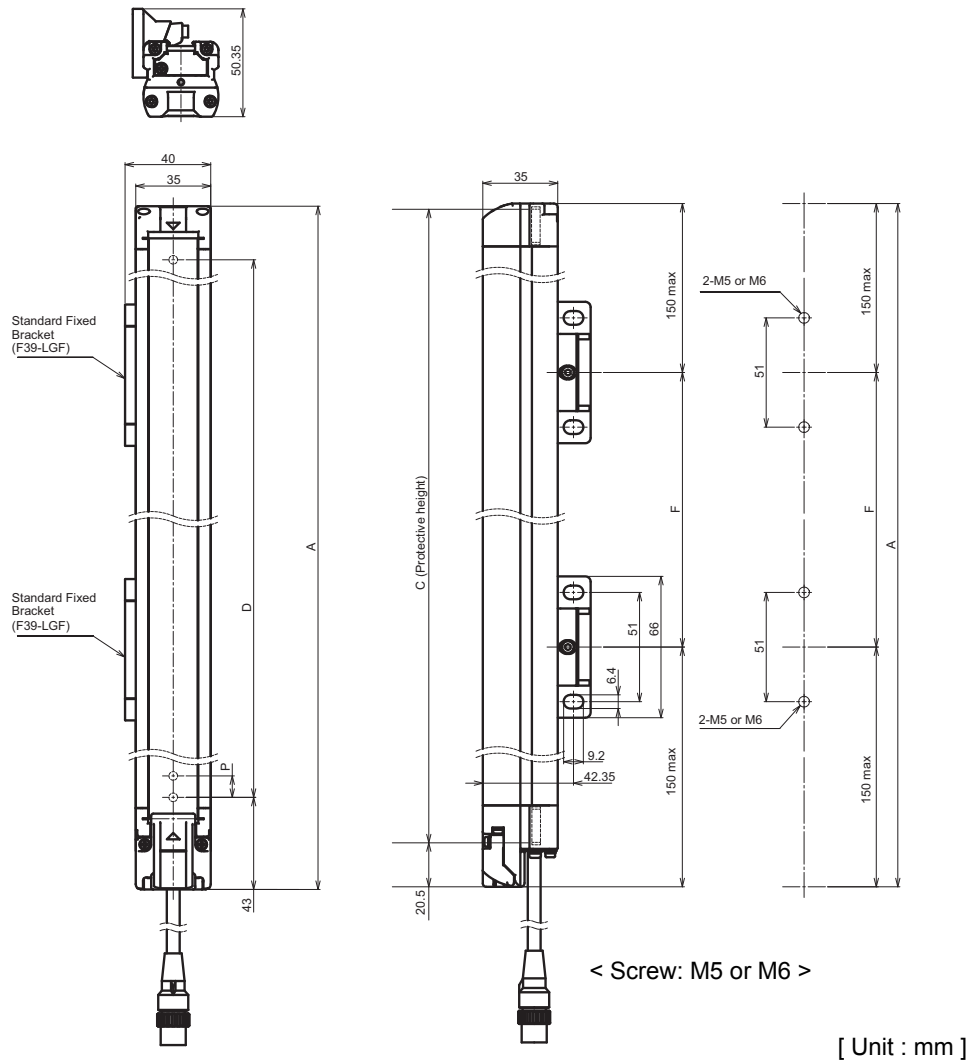

F3SG-4RA□□□□-25-01TS Series

Dimension A	C+23
Dimension C	4-digit number of the type name (Protective height)
Dimension D	C-45
Dimension P	20

Protective height (C)	Number of Standard Fixed Brackets *1	Dimension F
0185 to 1225	2 *2	1000 mm max.
1305 to 1945	3	1000 mm max.

*1. The number of brackets required to mount either one of emitter and receiver.

*2. Mounting an emitter or receiver with one bracket is possible for the models of protective height of 0185 or 0265. In this case, locate this bracket at half the Dimension A (or at the center of the sensor length).

 4-4-3-1. Mounting with Standard Fixed Brackets (F39-LGF)



CHECK!

- Use the brackets of specified quantities and locations according to the dimensions. The other brackets than described above may not meet the specified ratings and performance.
- When you use the sensor in a situation where the sensor is under a load, increase the number of the brackets used.
- The Standard Fixed Bracket does not allow beam alignment.

4-3-1-2. Standard Fixed Bracket

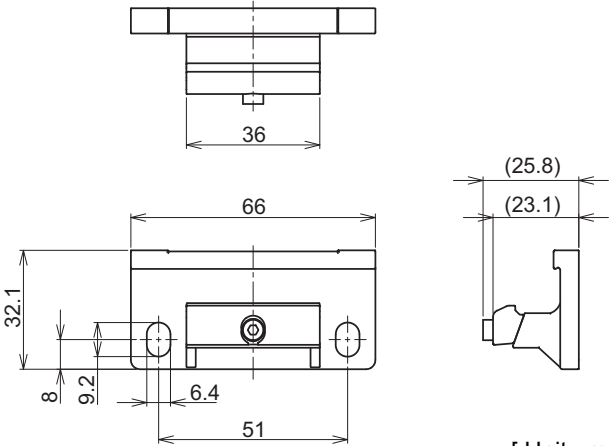

[Unit : mm]

Material: ZDC2

4-3-2. Mounted with Standard Adjustable Brackets (F39-LGA)

4-3-2-1. External Dimensions

■ Backside Mounting

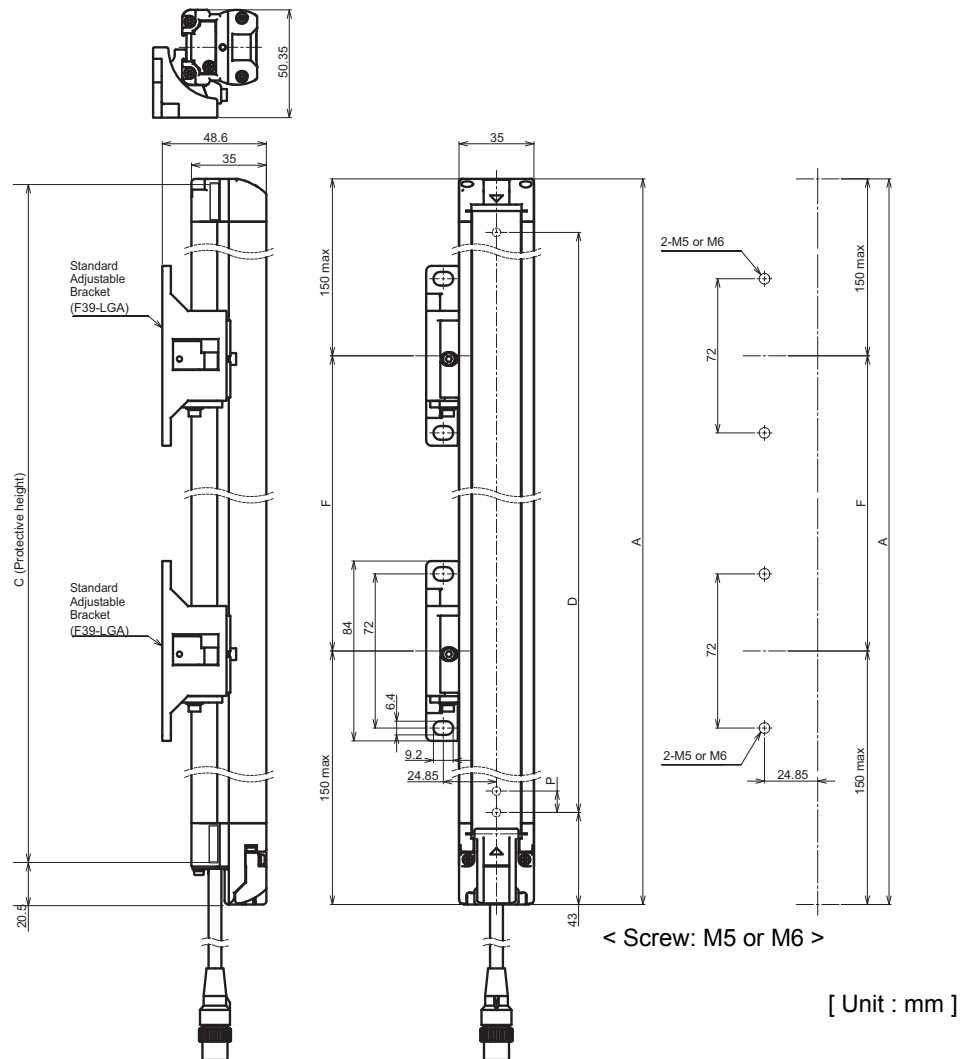

F3SG-4RA□□□□-25-01TS Series

Dimension A	C+23
Dimension C	4-digit number of the type name (Protective height)
Dimension D	C-45
Dimension P	20

Protective height (C)	Number of Standard Fixed Brackets *1	Dimension F
0185 to 1225	2 *2	1000 mm max.
1305 to 1945	3	1000 mm max.

*1. The number of brackets required to mount either one of emitter and receiver.

*2. Mounting an emitter or receiver with one bracket is possible for the models of protective height of 0185 or 0265. In this case, locate this bracket at half the Dimension A (or at the center of the sensor length).

4-4-3-2. Mounting with Standard Adjustable Brackets (F39-LGA)



CHECK!

- Use the brackets of specified quantities and locations according to the dimensions. The other brackets than described above may not meet the specified ratings and performance.
- When you use the sensor in a situation where the sensor is under a load, increase the number of the brackets used.
- The Standard Adjustable Bracket allows beam alignment after fixing the bracket to a wall surface. The angle adjustment range of the Standard Adjustable Brackets is $\pm 15^\circ$.

■ Side Mounting

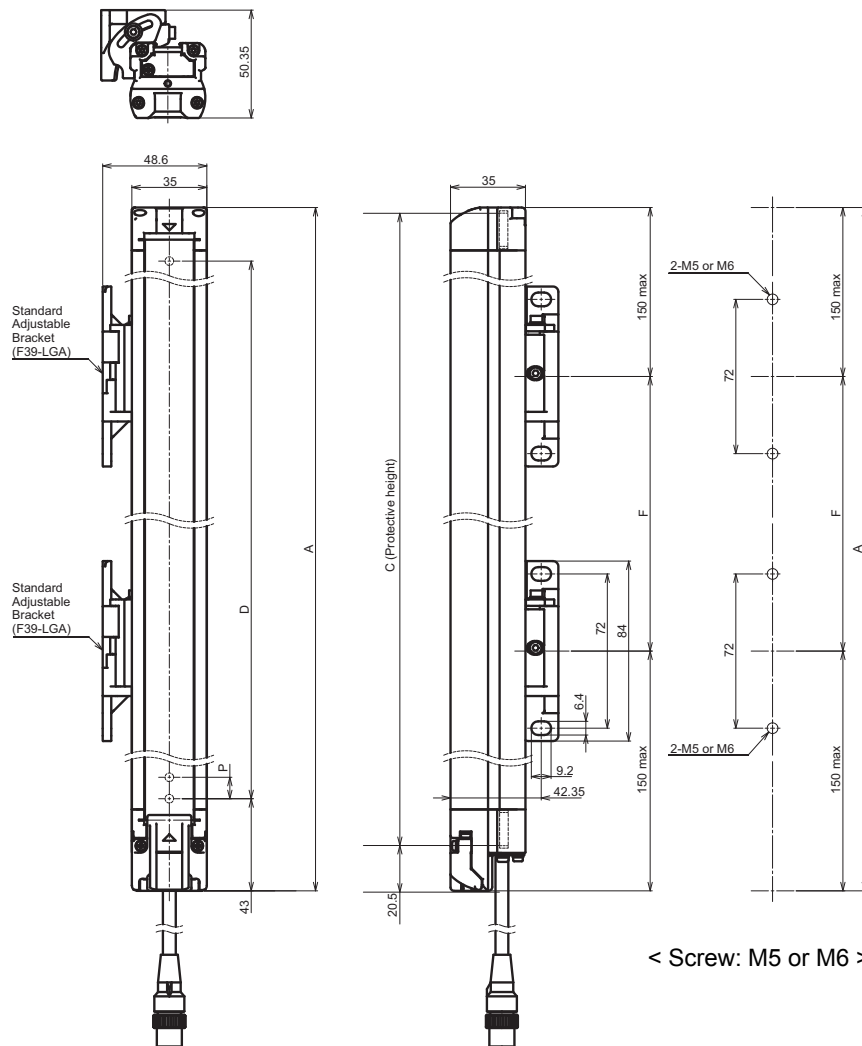

[Unit : mm]

F3SG-4RA□□□□-25-01TS Series

Dimension A	C+23
Dimension C	4-digit number of the type name (Protective height)
Dimension D	C-45
Dimension P	20

Protective height (C)	Number of Standard Fixed Brackets *1	Dimension F
0185 to 1225	2 *2	1000 mm max.
1305 to 1945	3	1000 mm max.

*1. The number of brackets required to mount either one of emitter and receiver.

*2. Mounting an emitter or receiver with one bracket is possible for the models of protective height of 0185 or 0265. In this case, locate this bracket at half the Dimension A (or at the center of the sensor length).

 4-4-3-2. Mounting with Standard Adjustable Brackets (F39-LGA)

-  - Use the brackets of specified quantities and locations according to the dimensions. The other brackets than described above may not meet the specified ratings and performance.
- CHECK!** - When you use the sensor in a situation where the sensor is under a load, increase the number of the brackets used.
- The Standard Adjustable Bracket allows beam alignment after fixing the bracket to a wall surface. The angle adjustment range of the Standard Adjustable Brackets is $\pm 15^\circ$.

4-3-2-2. Standard Adjustable Bracket

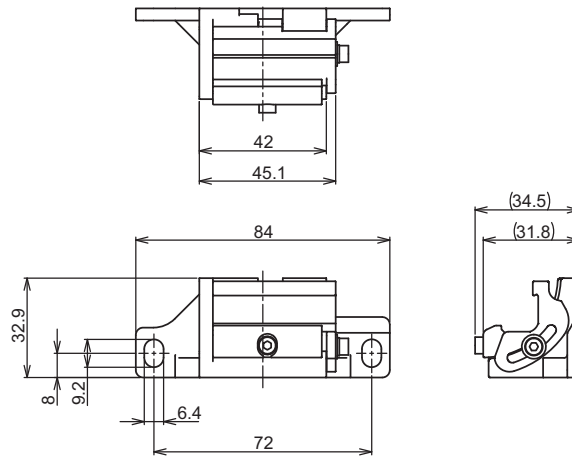

[Unit : mm]

Material: ZDC2, Fluorochemical lubricant oil

4-3-3. Mounted with Top/Bottom Adjustable Brackets (F39-LGTB) and Standard Adjustable Brackets (F39-LGA)

4-3-3-1. External Dimensions

■ F3SG-RA Series Except F3SG-4RA0185-25-01TS

[Backside Mounting]

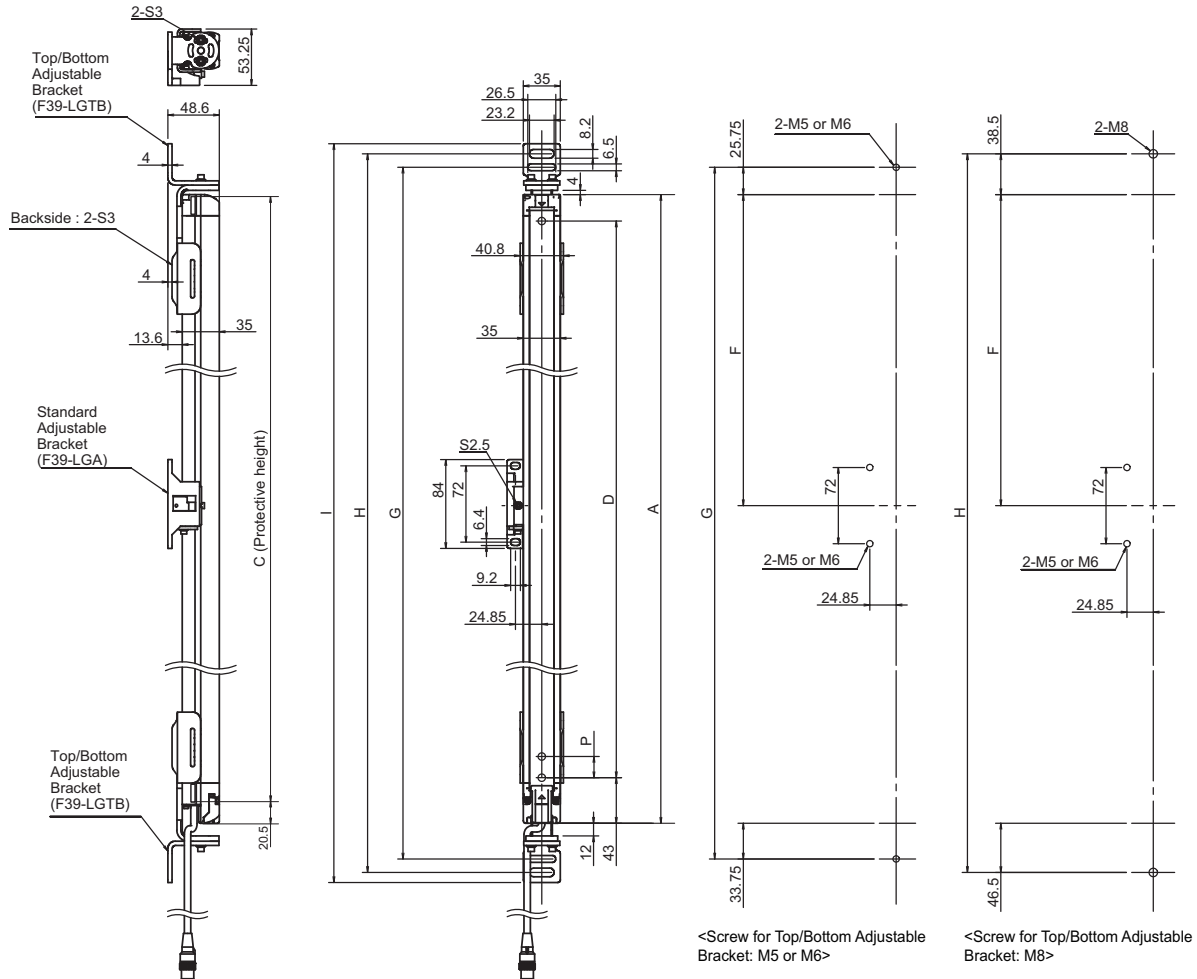

<Screw for Top/Bottom Adjustable Bracket: M5 or M6>

<Screw for Top/Bottom Adjustable Bracket: M8>

F3SG-4RA□□□□-25-01TS Series (Except for 0185)

[Unit : mm]

	Optional accessory not connected	Optional accessory connected*		
		F39-JGR2WTS	F39-BT	F39-LP F39-BTLP
Dimension A	C+23	Same as on the left		
Dimension C	4-digit number of the type name (Protective height)	Same as on the left		
Dimension D	C-45	Same as on the left		
Dimension G	C+82.5	C+85.5	C+96	C+107.5
Dimension H	C+108	C+111	C+121.5	C+133
Dimension I	C+127	C+130	C+140.5	C+152
Dimension P	20	Same as on the left		

* Refer to ■ Connected with Optional Accessories under 4-3-3-1. External Dimensions for more information on the dimensions when optional accessories are connected to the F3SG-RA.

Protective height (C)	Number of Top/Bottom Adjustable Brackets*1	Number of Standard Adjustable Brackets*1*2	Dimension F
0265 to 1065	2	0	-
1145 to 1945	2	1	1000 mm max.

*1. The number of brackets required to mount either one of emitter and receiver.

*2. The Top/Bottom Adjustable Bracket is not useable together with the Standard Fixed Bracket. When it is necessary to use it with another bracket, only the combination with the Standard Adjustable Bracket is possible.



4-4-3-3. Mounting with Top/Bottom Adjustable Brackets (F39-LGTB)

- Use the brackets of specified quantities and locations according to the dimensions. The other brackets than described above may not meet the specified ratings and performance.
- When you use the sensor in a situation where the sensor is under a load, increase the number of the brackets used.
- The Top/Bottom Adjustable Bracket and Standard Adjustable Bracket allow beam alignment after fixing the bracket to a wall surface. The angle adjustment range of the Top/Bottom Adjustable Brackets is ±22.5°. The angle adjustment range of the Standard Adjustable Brackets is ±15°.

[Side Mounting]

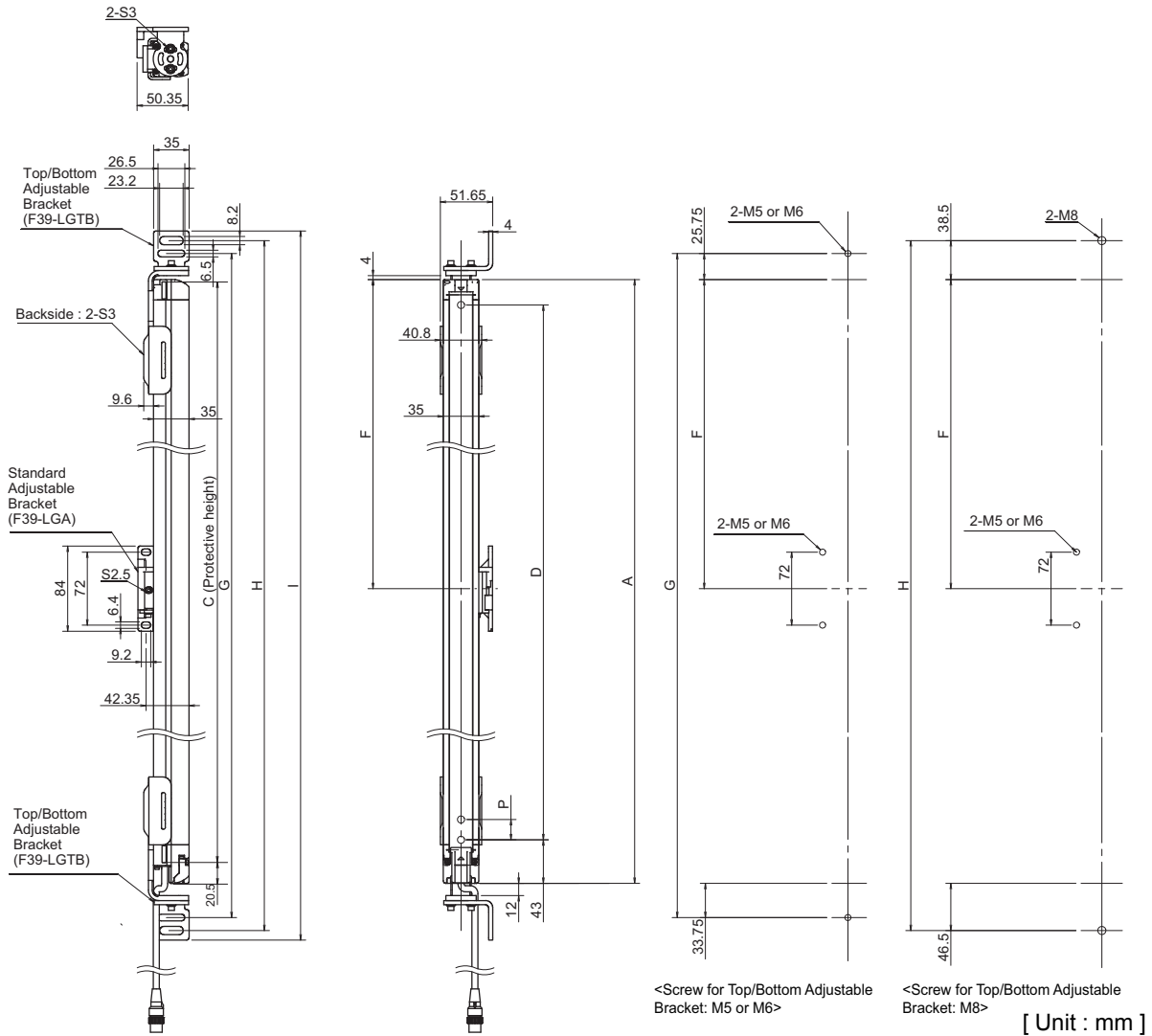

F3SG-4RA□□□□-25-01TS Series (Except for 0185)

	Optional accessory not connected	Optional accessory connected*		
		F39-JGR2WTS	F39-BT	F39-LP F39-BTLP
Dimension A	C+23	Same as on the left		
Dimension C	4-digit number of the type name (Protective height)	Same as on the left		
Dimension D	C-45	Same as on the left		
Dimension G	C+82.5	C+85.5	C+96	C+107.5
Dimension H	C+108	C+111	C+121.5	C+133
Dimension I	C+127	C+130	C+140.5	C+152
Dimension P	20	Same as on the left		

* Refer to ■ Connected with Optional Accessories under 4-3-3-1. External Dimensions for more information on the dimensions when optional accessories are connected to the F3SG-RA.

Protective height (C)	Number of Top/Bottom Adjustable Brackets*1	Number of Standard Adjustable Brackets *1 *2	Dimension F
0265 to 1065	2	0	-
1145 to 1945	2	1	1000 mm max.

*1. The number of brackets required to mount either one of emitter and receiver.

*2. The Top/Bottom Adjustable Bracket is not useable together with the Standard Fixed Bracket. When it is necessary to use it with another bracket, only the combination with the Standard Adjustable Bracket is possible.



4-4-3-3. Mounting with Top/Bottom Adjustable Brackets (F39-LGTB)

- Use the brackets of specified quantities and locations according to the dimensions. The other brackets than described above may not meet the specified ratings and performance.
- When you use the sensor in a situation where the sensor is under a load, increase the number of the brackets used.
- The Top/Bottom Adjustable Bracket and Standard Adjustable Bracket allow beam alignment after fixing the bracket to a wall surface. The angle adjustment range of the Top/Bottom Adjustable Brackets is $\pm 22.5^\circ$. The angle adjustment range of the Standard Adjustable Brackets is $\pm 15^\circ$.

CHECK!

■ F3SG-4RA0185-25-01TS

[Backside Mounting]

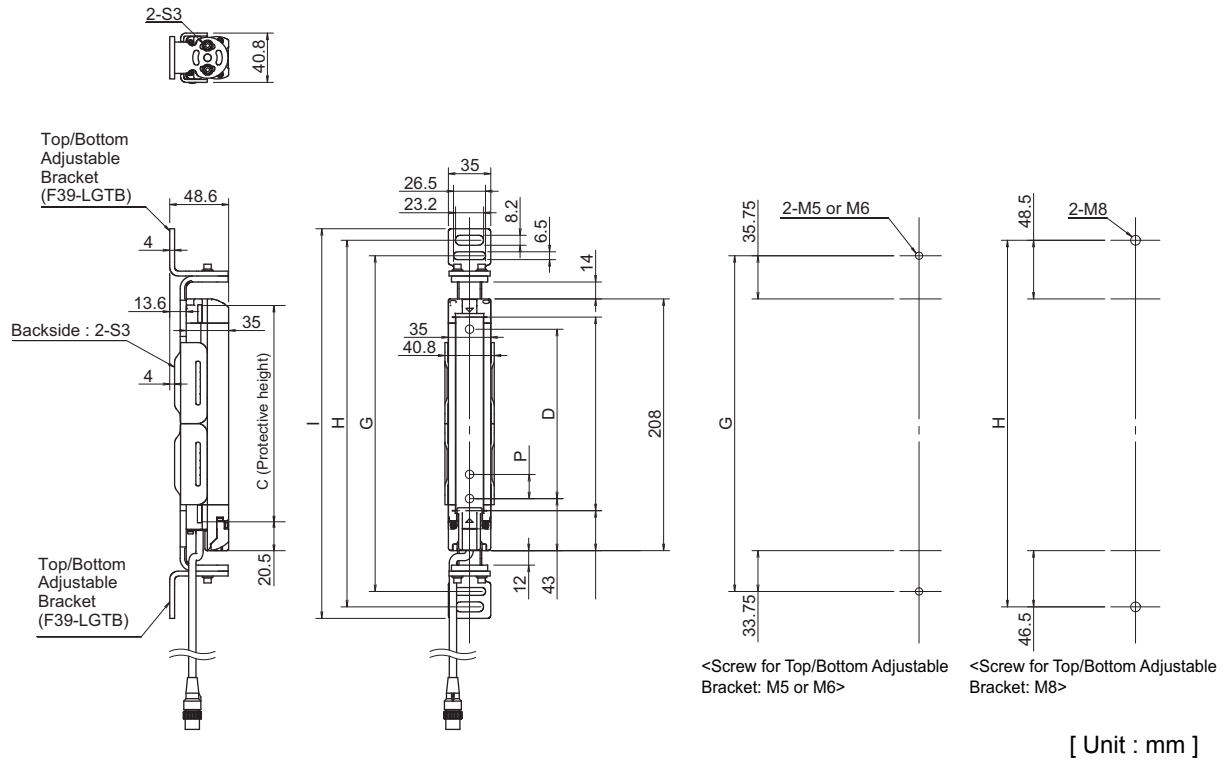

[Unit : mm]

F3SG-4RA0185-25-01TS

	Optional accessory not connected	Optional accessory connected*1		
		F39-JGR2WTS	F39-BT	F39-LP F39-BTLP
Dimension C	185	Same as on the left		
Dimension D	140	Same as on the left		
Dimension G	277.5	277.5	281	292.5
Dimension H	303	303	306.5	318
Dimension I	322	322	325.5	337
Dimension P	20	Same as on the left		
Number of Top/Bottom Adjustable Brackets*2	2	Same as on the left		

*1. Refer to ■ Connected with Optional Accessories under 4-3-3-1. External Dimensions for more information on the dimensions when optional accessories are connected to the F3SG-RA.

*2. The number of brackets required to mount either one of emitter and receiver.

4-4-3-3. Mounting with Top/Bottom Adjustable Brackets (F39-LGTB)

- Use the brackets of specified quantities and locations according to the dimensions. The other brackets than described above may not meet the specified ratings and performance.
 - When you use the sensor in a situation where the sensor is under a load, increase the number of the brackets used.
- CHECK!
- The Top/Bottom Adjustable Bracket and Standard Adjustable Bracket allow beam alignment after fixing the bracket to a wall surface. The angle adjustment range of the Top/Bottom Adjustable Brackets is $\pm 22.5^\circ$. The angle adjustment range of the Standard Adjustable Brackets is $\pm 15^\circ$.

[Side Mounting]

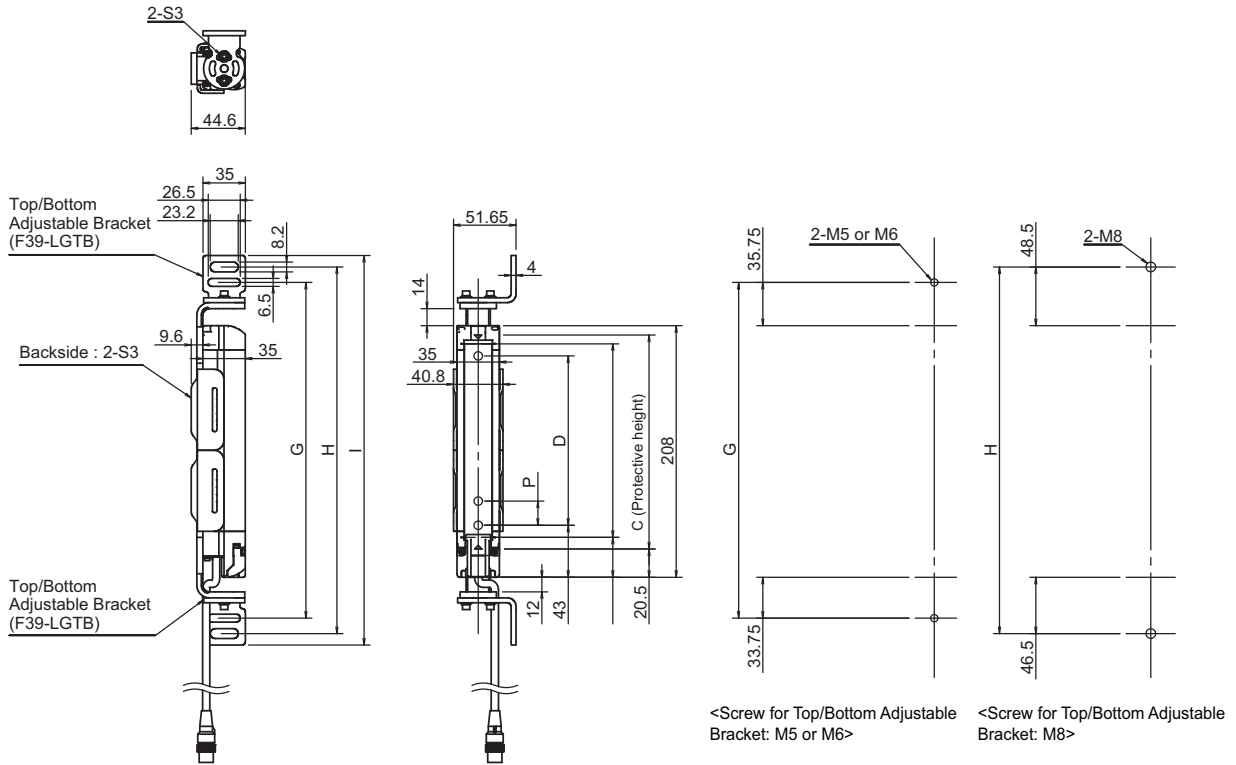

F3SG-4RA0185-25-01TS

[Unit : mm]

	Optional accessory not connected	Optional accessory connected*1		
		F39-JGR2WTS	F39-BT	F39-LP F39-BTLP
Dimension C	185	Same as on the left		
Dimension D	140	Same as on the left		
Dimension G	277.5	277.5	281	292.5
Dimension H	303	303	306.5	318
Dimension I	322	322	325.5	337
Dimension P	20	Same as on the left		
Number of Top/Bottom Adjustable Brackets*2	2	Same as on the left		

*1. Refer to ■ Connected with Optional Accessories under 4-3-3-1. External Dimensions for more information on the dimensions when optional accessories are connected to the F3SG-RA.

*2. The number of brackets required to mount either one of emitter and receiver.



4-4-3-3. Mounting with Top/Bottom Adjustable Brackets (F39-LGTB)

- Use the brackets of specified quantities and locations according to the dimensions. The other brackets than described above may not meet the specified ratings and performance.
 - When you use the sensor in a situation where the sensor is under a load, increase the number of the brackets used.
- CHECK!
- The Top/Bottom Adjustable Bracket and Standard Adjustable Bracket allow beam alignment after fixing the bracket to a wall surface. The angle adjustment range of the Top/Bottom Adjustable Brackets is $\pm 22.5^\circ$. The angle adjustment range of the Standard Adjustable Brackets is $\pm 15^\circ$.

■ Connected with Optional Accessories

- Connected with Cascading Cable (F39-JGR2WTS) (Enlarged view of connected area)

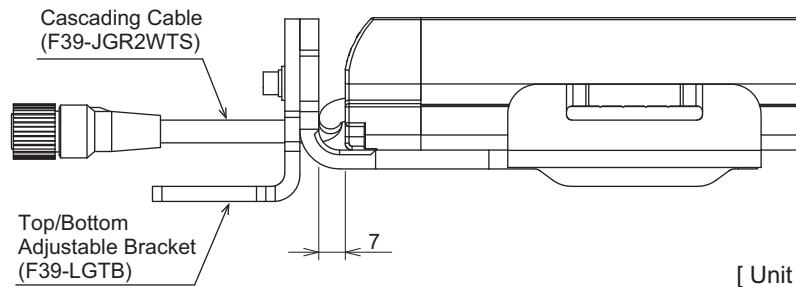
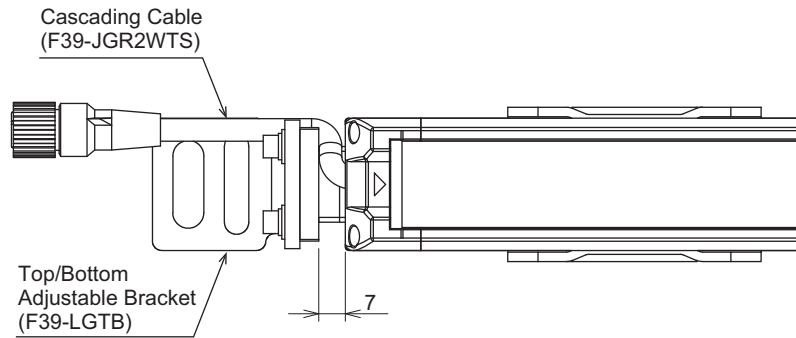

[Unit : mm]

- Connected with Lamp (F39-LP) (Enlarged view of connected area)

Receiver

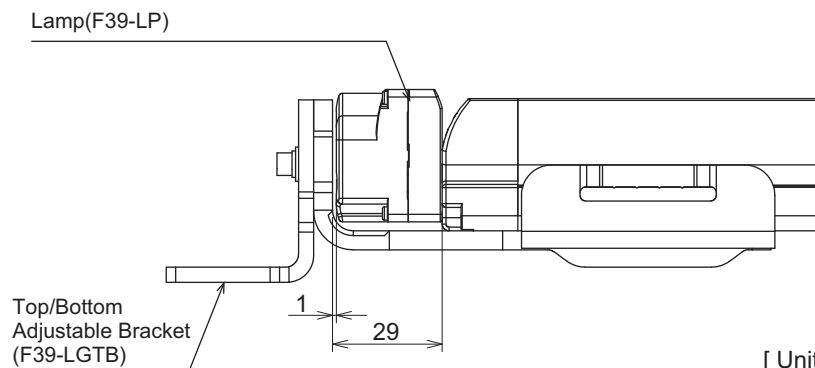
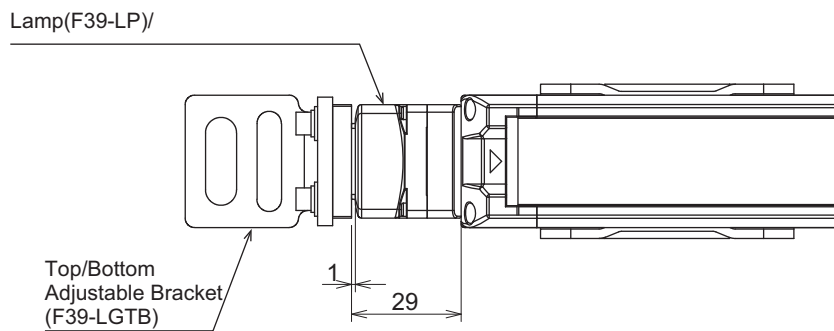

[Unit : mm]

- DIP Switch cover opened (Enlarged view of connected area)

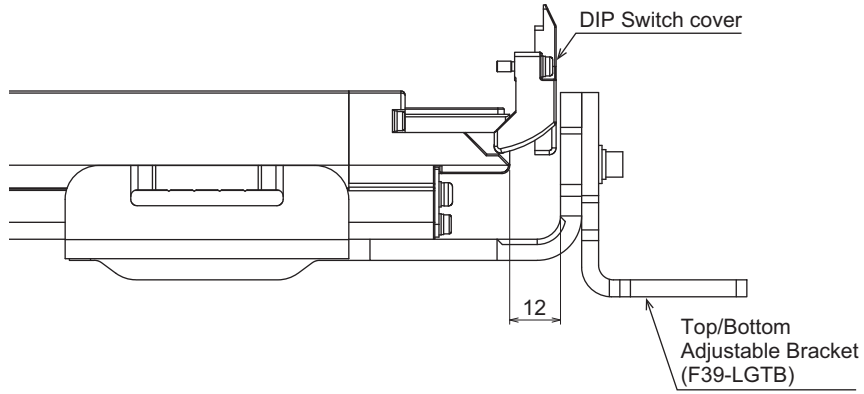

[Unit : mm]

4-3-3-2. Top/Bottom Adjustable Bracket (F39-LGTB)

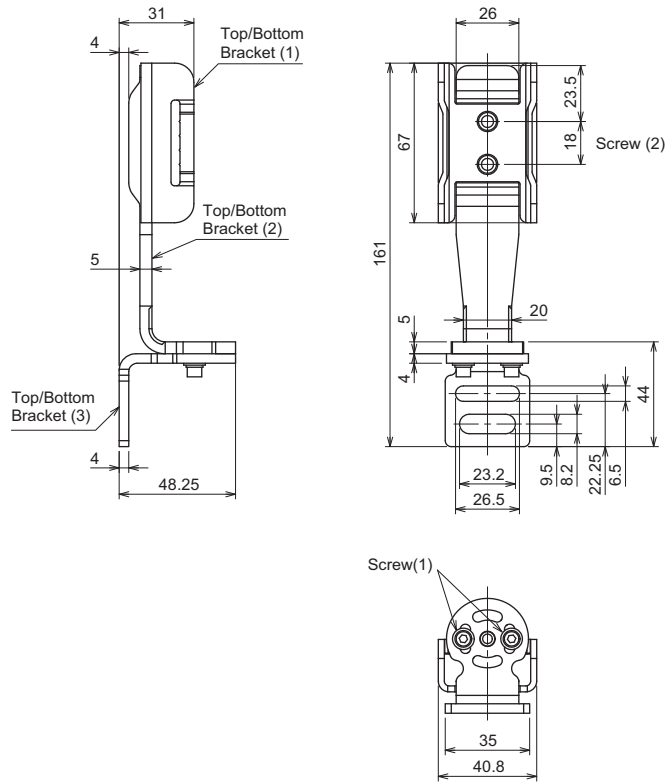

[Unit : mm]

Material: SUS304

4-3-3-3. Top/Bottom Adjustable Bracket (F39-LGTB-1)

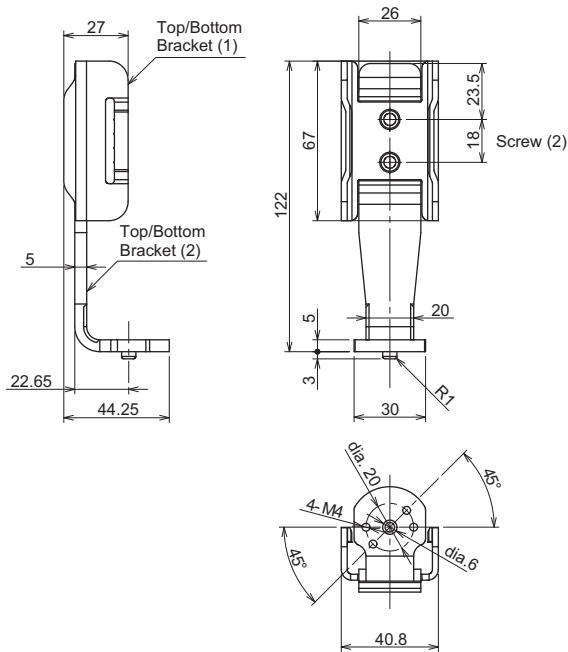

[Unit : mm]

Material: SUS304

Note: F39-LGTB-1 does not come with Top/Bottom Bracket (3) and Screw (1). Refer to 4-4-3-3. *Mounting with Top/Bottom Adjustable Brackets (F39-LGTB)* for more information on parts names of this bracket.

[Reference information]

When you design the joint part with the Top/Bottom Bracket (2), refer to the drawing below.

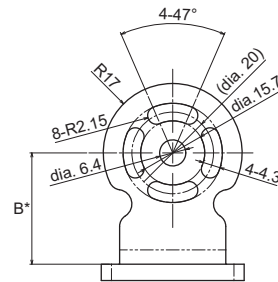

* When you use this bracket with the Standard Adjustable Bracket (F39-LGA), the Dimension B must be 27.25 mm.

4-4. Mounting

4-4-1. Mounting Method

You can mount the F3SG-R with Standard Fixed Brackets and Standard Adjustable Brackets. Any of these mounting methods allows the user to use the same bracket for the backside mounting and side mounting.

4-4-2. Number of Brackets Required

The numbers of brackets required according to the protective heights of the sensor are as follows:

- Mounting with Standard Fixed Brackets Only

Protective height	Number of Standard Fixed Brackets *1
F3SG-4RA□□□□-25-01TS	
0185 to 1225	2 *2
1305 to 1945	3

Note: The Standard Fixed Bracket is included with the F3SG-R product package. The quantity included varies depending on the protective height.

- Mounting with Standard Adjustable Brackets Only

Protective height	Number of Standard Adjustable Brackets *1
F3SG-4RA□□□□-25-01TS	
0185 to 1225	2 *2
1305 to 1945	3

- Mounting with Top/Bottom Adjustable Brackets and Standard Adjustable Brackets

Protective height	Number of Top/Bottom Adjustable Brackets *1	Number of Standard Adjustable Brackets *1
F3SG-4RA□□□□-25-01TS		
0185 to 1065	2	0
1145 to 1945	2	1

*1. The number of brackets required to mount either one of emitter and receiver.

*2. Mounting an emitter or receiver with one bracket is possible for the models of protective height of 0185 or 0265.



CHECK!

Make sure that the F3SG-R is securely mounted and its cables and connectors are properly connected.

4-4-3. Mounting Procedure

■ Before mounting

When it is required to configure functions with DIP Switch, do so before installing the F3SG-R in your site, according to the procedure described in 3-2. *DIP Switch*.

4-4-3-1. Mounting with Standard Fixed Brackets (F39-LGF)

1. Loosen the hexagon socket head cap screws (M3 x 15). (Fig.1)

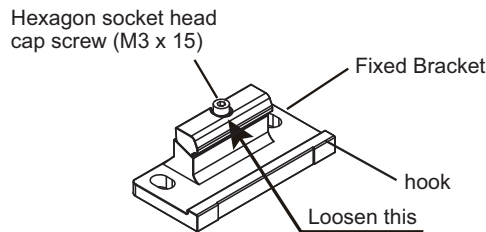

Fig. 1

2. Slide the hook of the Fixed Bracket (1) in the groove of the F3SG-R housing. Lightly tighten the hexagon socket head cap screw (M3 x 15). (Fig. 2)

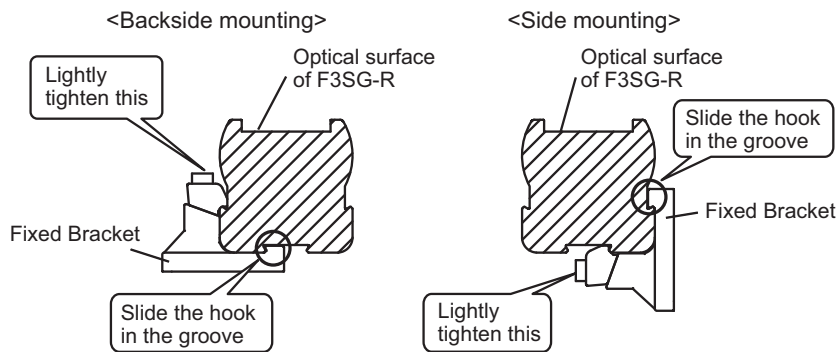

Fig. 2

3. Adjust the Standard Fixed Bracket to the mounting position of the wall surface. Securely tighten the hexagon socket head cap screw (M3 x 15) to fix the Standard Fixed Bracket to the housing of the F3SG-R. The recommended torque to tighten the hexagon socket head cap screw (M3 x 15) is 2.0 N•m. (Fig. 3)

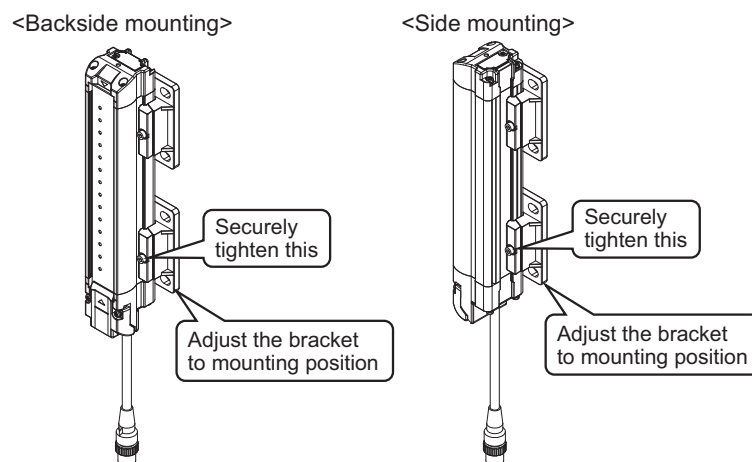

Fig. 3



Tightening screws with a torque that considerably exceeds the recommended torque may cause failure.

- Securely tighten the screws to fix the Standard Fixed Bracket to the mounting position of the wall surface. (Fig. 4)

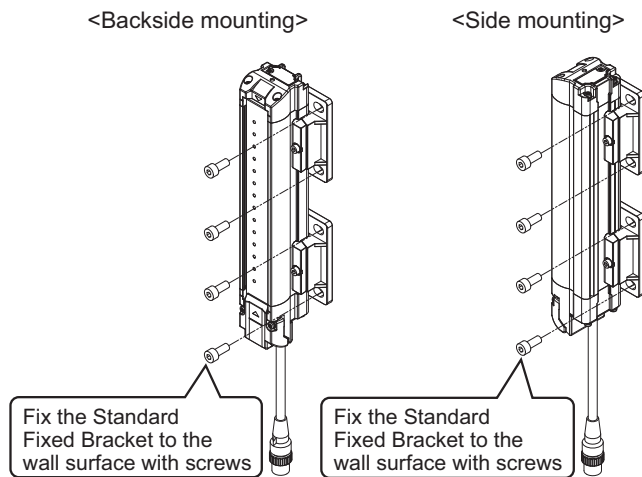

Fig. 4



Screws to mount the brackets to the wall are not included.

4-4-3-2. Mounting with Standard Adjustable Brackets (F39-LGA)

- Loosen the Screw (1) (hexagon socket head cap screw (M3 x 15)) and change the angle of the Adjustable Bracket (1) according to its mounting direction. (Fig. 1)
- Loosen the Screw (2) (hexagon socket head cap screw (M3 x 15)). (Fig. 1)

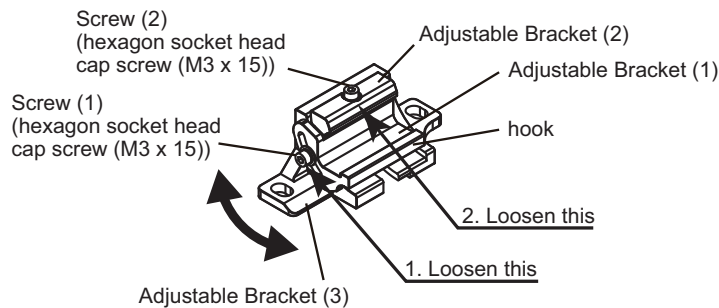

Fig. 1

- Slide the hooks of the Adjustable Bracket (1) and the Adjustable Bracket (2) in the grooves of the F3SG-R housing. Lightly tighten the Screw (2). (Fig. 2)

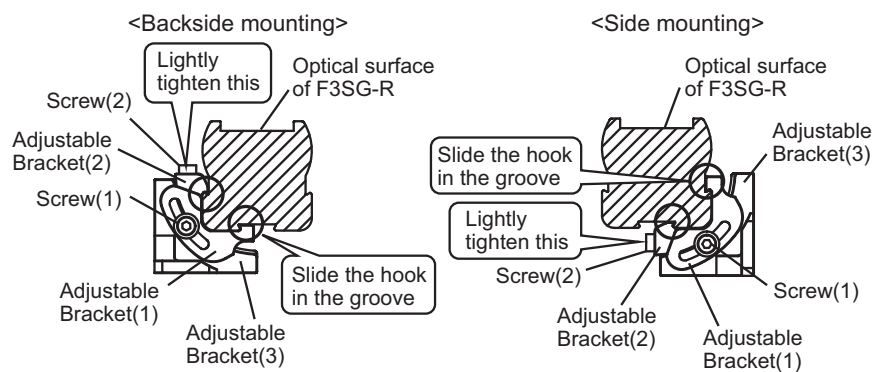

Fig. 2

- Adjust the Standard Adjustable Bracket to the mounting position of the wall surface. Securely tighten the Screw (2) to fix the Standard Adjustable Bracket to the housing of the F3SG-R. The recommended torque to tighten the Screw (2) is 2.0 N•m. (Fig. 3)

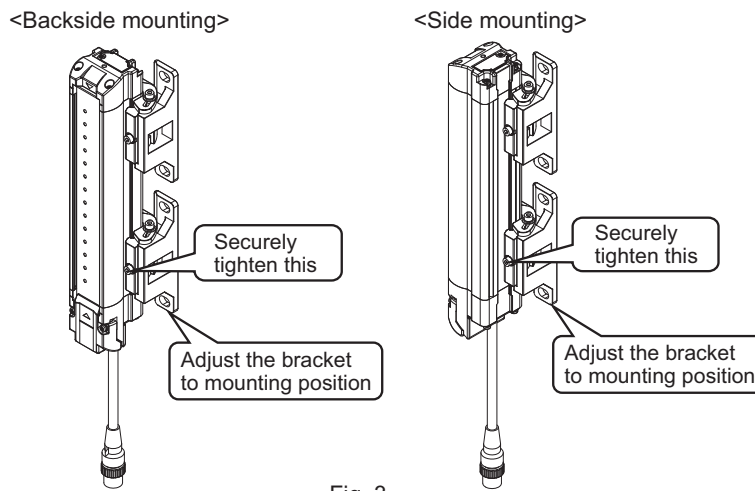

Fig. 3



CHECK!

Tightening screws with a torque that considerably exceeds the recommended torque may cause failure.

- Securely tighten screws to fix the Standard Adjustable Bracket to the mounting position of the wall surface. (Fig. 4)

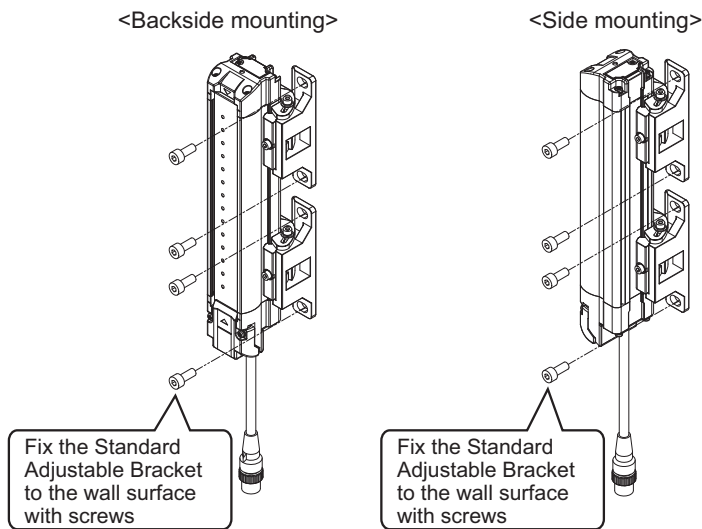

Fig. 4



CHECK!

Screws to mount the brackets to the wall are not included.

6. Power the F3SG-R on to perform beam alignment.

Move the emitter from side to side (Fig. 5) to align it to a center position where the Stable-state indicator (STB, green) of the receiver is illuminated while checking the state of the top and bottom beams with the TOP indicator (TOP, blue) and BTM indicator (BTM, blue) of the receiver. (Fig. 6)

Next, move the receiver from side to side to align it to a center position where the Stable-state indicator (STB, green) of the receiver is illuminated while checking the state of the top and bottom beams with the TOP indicator (TOP, blue) and BTM indicator (BTM, blue) of the receiver.

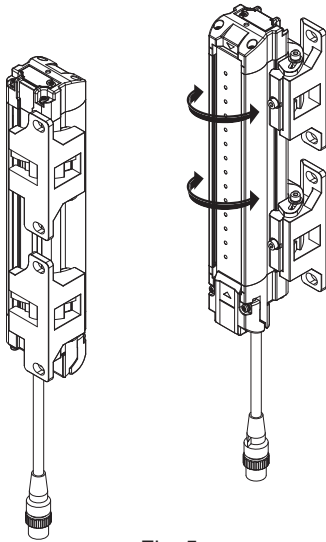

Fig. 5

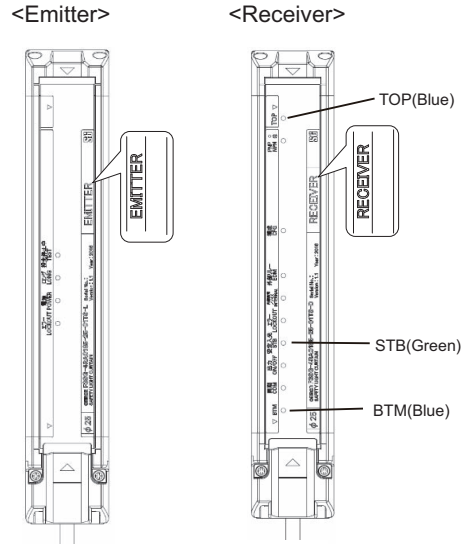

Fig. 6



CHECK!

The angle adjustment range of the Standard Adjustable Brackets is $\pm 15^\circ$.

7. Securely tighten the Screw (1) to fix the Standard Adjustable Bracket to the housing of the F3SG-R. The recommended torque to tighten the Screw (1) is 2.0 N•m. (Fig. 7)

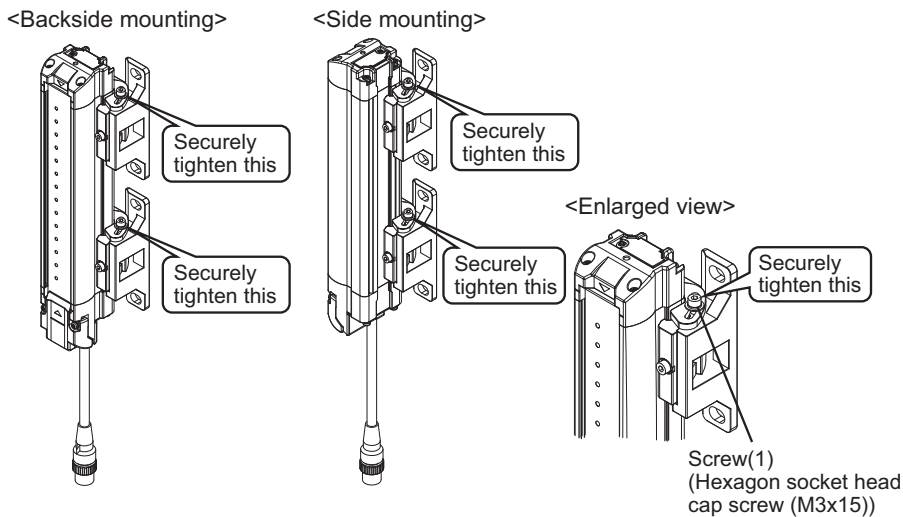

Fig. 7



CHECK!

Tightening screws with a torque that considerably exceeds the recommended torque may cause failure.

4-4-3-3. Mounting with Top/Bottom Adjustable Brackets (F39-LGTB)

1. Loosen the Screw (1) (hexagon socket head cap screw (M4×10)) of Top/Bottom Bracket (3) and change the angle of the Top/Bottom Bracket (3) according to its mounting direction. Then loosen the Screw (2) (low head hexagon socket head cap screw (M5×10)) of Top/Bottom Bracket (2). (Fig. 1)

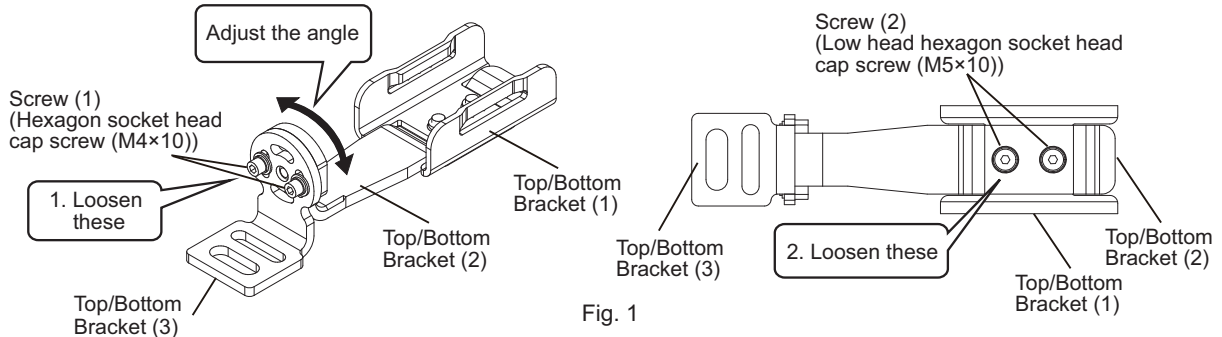

The width across flat of the hexagon socket of the Screws (1) and (2) is $S=3$.

CHECK!

2. Slide the Top/Bottom Bracket (1) in the grooves of the F3SG-R housing. Adjust the Top/Bottom Adjustable Bracket to the mounting position of the wall surface. Make sure to position the whole body of the Top/Bottom Bracket (1) within the yellow area of the housing. Securely tighten the Screw (2) to fix the Top/Bottom Adjustable Bracket to the housing of the F3SG-R. The recommended torque to tighten the Screw (2) is 3.0 N•m. (Fig. 2)

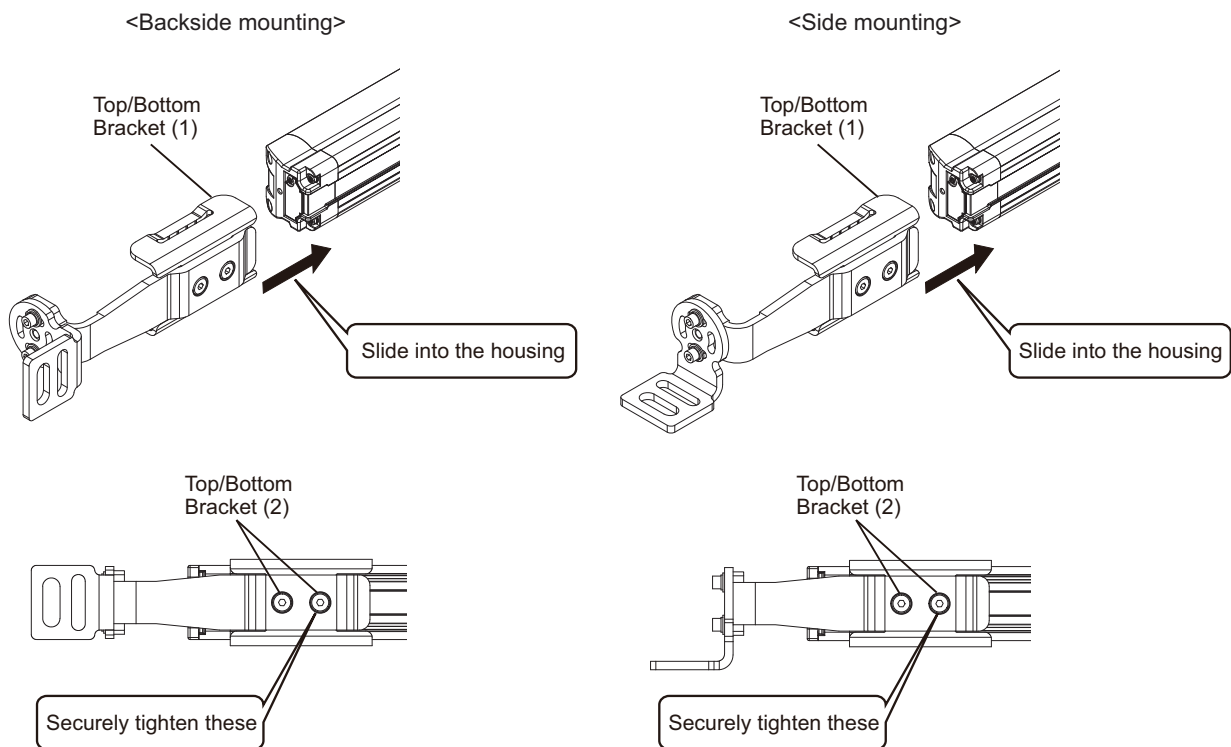

Tightening screws with a torque that considerably exceeds the recommended torque may cause failure.

CHECK!

- Securely tighten screws to fix the Top/Bottom Adjustable Bracket to the mounting position of the wall surface. (Fig. 3)

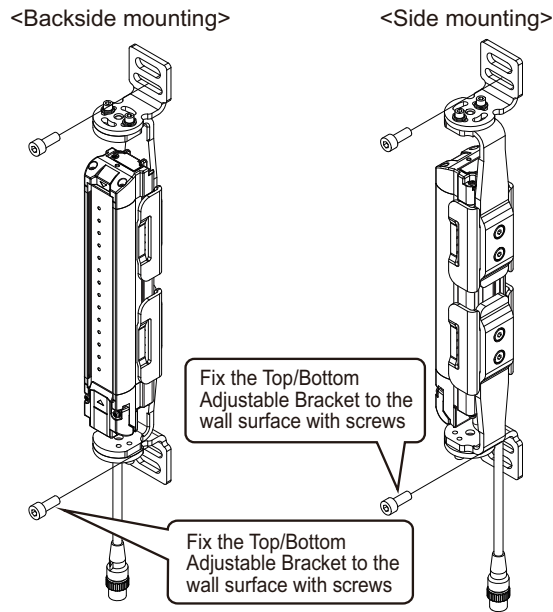

Fig. 3



CHECK!

One screw at upper and lower positions, respectively, is sufficient to fix the F3SG-R to the wall surface. Screws to mount the brackets to the wall are not included.

- Power the F3SG-R on to perform beam alignment.

Move the emitter from side to side (Fig. 4) to align it to a center position where the Stable-state indicator (STB, green) of the receiver is illuminated while checking the state of the top and bottom beams with the TOP indicator (TOP, blue) and BTM indicator (BTM, blue) of the receiver. (Fig. 5) Next, move the receiver from side to side to align it to a center position where the Stable-state indicator (STB, green) of the receiver is illuminated while checking the state of the top and bottom beams with the TOP indicator (TOP, blue) and BTM indicator (BTM, blue) of the receiver.

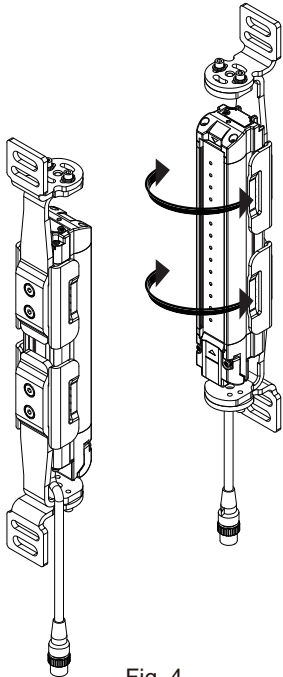

Fig. 4

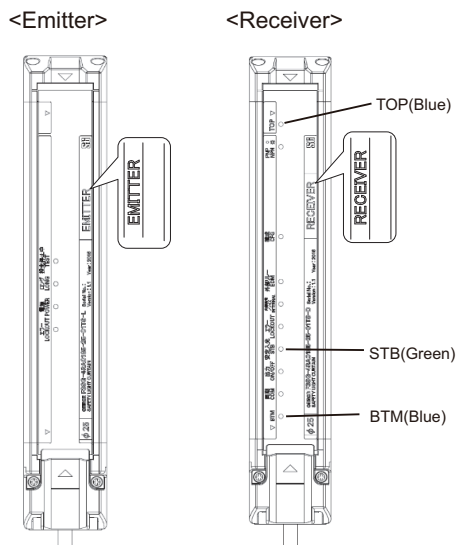

Fig. 5



CHECK!

The angle adjustment range of the Top/Bottom Adjustable Brackets is $\pm 22.5^\circ$.

5. Securely tighten the Screw (1) to fix the Top/Bottom Adjustable Bracket to the housing of the F3SG-R. The recommended torque to tighten the Screw (1) is 3.0 N•m. (Fig. 6)

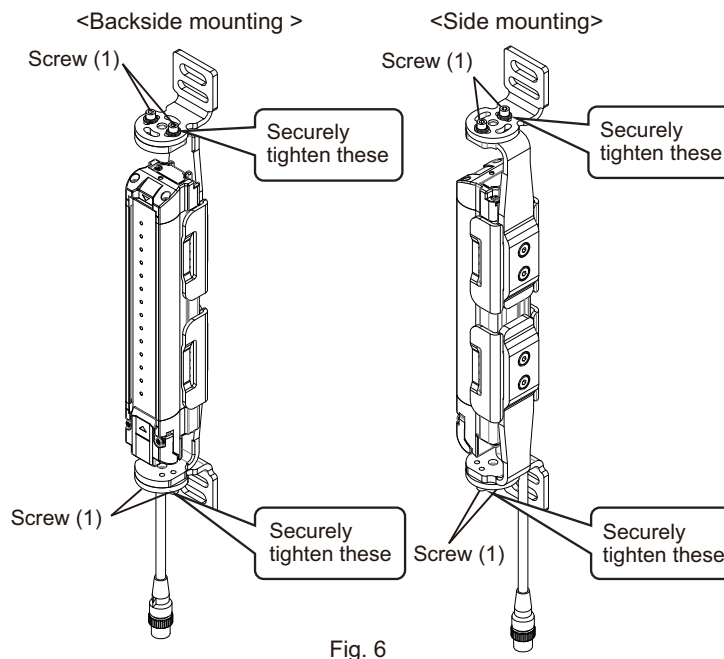

Tightening screws with a torque that considerably exceeds the recommended torque may cause failure.

CHECK!

4-4-4. Beam Alignment Procedure



The Standard Adjustable Bracket and Top/Bottom Adjustable Bracket allow beam alignment after fixing the bracket to a wall surface. The Standard Fixed Bracket does not allow beam alignment.

CHECK!

1. Verify the following points:
 - The optical surfaces of the emitter and receiver are clean.
 - There is no interrupting object in the detection zone of the F3SG-R.

2. Align the beams of the emitter and receiver:

Move the emitter from side to side to align it to a center position where the Stable-state indicator (STB, green) of the receiver is illuminated while checking the state of the top and bottom beams with the TOP indicator (TOP, blue) and BTM indicator (BTM, blue) of the receiver.

Next, move the receiver from side to side to align it to a center position where the Stable-state indicator (STB, green) of the receiver is illuminated while checking the state of the top and bottom beams with the TOP indicator (TOP, blue) and BTM indicator (BTM, blue) of the receiver.



1-4. LED Indicators



Perform beam alignment to the primary sensor first, when using the F3SG-R in a cascade connection.

CHECK!

3. Verify that all the three indicators of the receiver, TOP (TOP, blue), BTM (BTM, blue) and Stable-state (STB, green) indicators are illuminated.
4. Make sure to keep the beams aligned and tightly fasten all screws.
The table below shows the recommended tightening torques for the included screws.

Mounting bracket type	Nominal diameter x length of screw (mm)	Tightening torque (recommended)
Standard Fixed Bracket	M3 x 15	2.0 N•m
Standard Adjustable Bracket		
Top/Bottom Adjustable Bracket	M4 x 10 M5 x 10	3.0 N•m









- If any of the TOP (TOP, blue), BTM (BTM, blue) and Stable-state (STB, green) indicators are not illuminated, check if the emitter and receiver are mounted parallel and at the same height.

CHECK! - Tightening screws with a torque that considerably exceeds the recommended torque may cause failure.

4-5. Wiring

4-5-1. Wiring Precautions

⚠ WARNING	
Double or reinforced insulation from hazardous voltage must be applied to all input and output lines. Failure to do so may result in electric shock.	
When using PNP output, connect the load between the output and 0 V line. When using NPN output, connect the load between the output and +24 VDC line. Connecting between the output and a different power supply line from the above line will result in dangerous condition because the operation mode of safety output is reversed to "Dark-ON".	
When using the PNP output, do not ground +24 VDC line. When using the NPN output, do not ground 0 V line. Otherwise, a ground fault may turn the safety output ON, resulting in a failure of stopping the machine.	
Configure the system by using the optimal number of safety outputs that satisfy the requirements of the necessary safety category.	
Do not connect each line of F3SG-R to a DC power supply higher than 24 VDC+20%. Also, do not connect it to an AC power supply. Failure to do so may result in electric shock.	
Make sure to perform wiring while the power supply is OFF.	

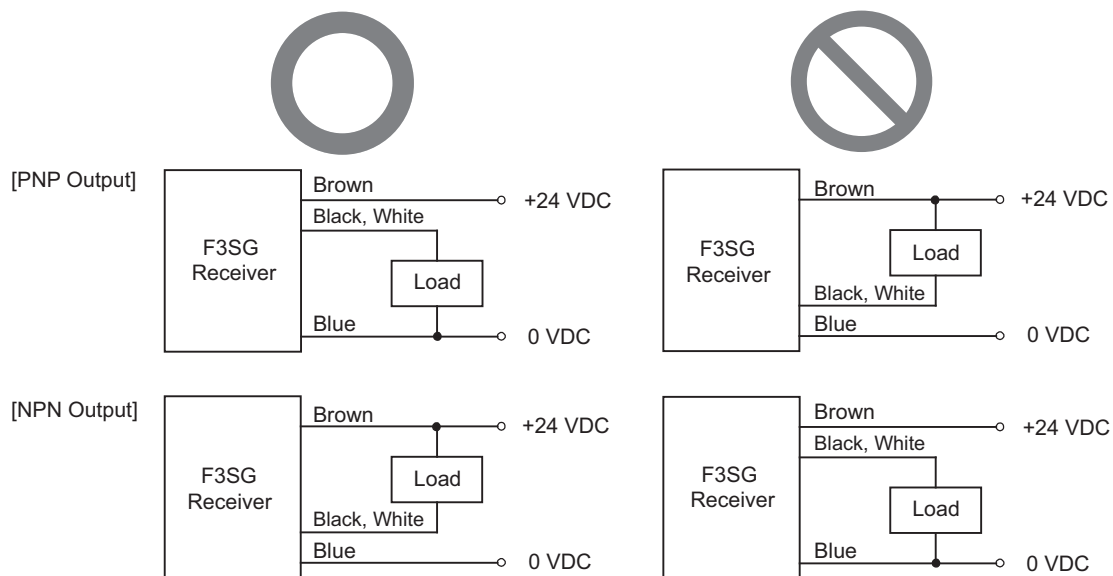

4-5-2. Power Supply Unit

WARNING

For the F3SG-R to comply with IEC 61496-1 and UL 508, the DC power supply unit must satisfy all of the following conditions:



- Must be within the rated power voltage (24 V DC \pm 20%)
- Must have tolerance against the total rated current of devices if it is connected to multiple devices
- Must comply with EMC directives (industrial environment)
- Double or reinforced insulation must be applied between the primary and secondary circuits
- Automatic recovery of overcurrent protection characteristics
- Output holding time must be 20ms or longer
- Must satisfy output characteristic requirements for class 2 circuit or limited voltage current circuit defined by UL508 (Refer to Note below.)
- **Must comply with laws and regulations, regarding EMC and electrical equipment safety, of the country or region where the F3SG-R is used (For example, in EU, the power supply must comply with the EMC Directive and the Low Voltage Directive.)**

Note:

To prevent a fire, the secondary circuit of the power supply must satisfy either of the following conditions in accordance with UL 508:

- As with secondary winding of isolation transformer, there must be a limited current voltage circuit to which isolated power supply provides power, and the "current is limited to 8 A max. (including short-circuit)" or "circuit protection such as a fuse is used to limit the current, which has a rating of 4.2A max." (24 VDC power supply).

Recommended power supply: OMRON S8VS (30 W or 60 W) or S8VK-G (15W, 30W or 60W)

These products are UL-Listed (UL508, class 2 power supply), CE marking compatible (EMC/Low Voltage Directive).

- Class 2 power supply unit complying with UL 1310, or a circuit using 2 transformers complying with UL 1585 as a power supply.

4-5-3. Cable Connections

⚠ WARNING

Extension of the cable must be within a specified length. If it isn't, safety function may not work properly, resulting in danger.



Perform wiring according to the following procedure.

1. Connect an emitter cable (F39-JD□-L, gray, sold separately) to the emitter-side power cable (gray).
2. Connect a receiver cable (F39-JD□-D, black, sold separately) to the receiver-side power cable (black).

4-5-3-1. Single-Ended Cable

- Single-Ended Cable for Emitter (F39-JD□A-L, sold separately)

(Unit: mm)

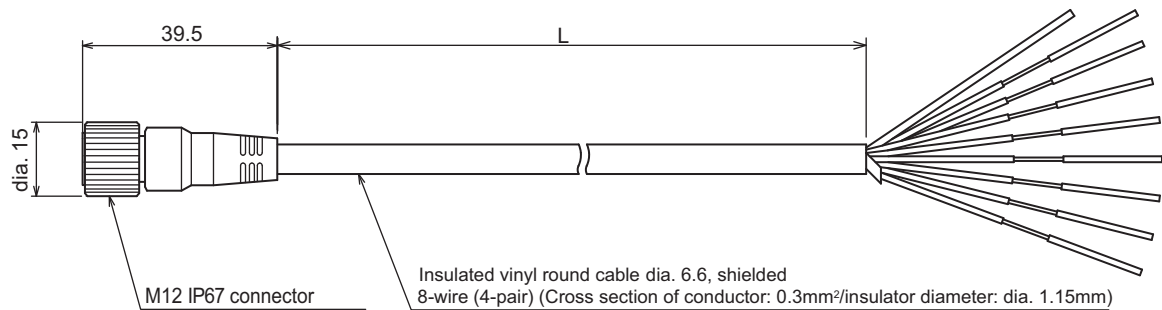

<Internal wiring diagram>

Connected to Power Cable or Double-Ended Cable

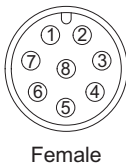

Female

1	White	Not used
2	Brown	+24V DC
3	Black	TEST
4	Yellow	Not used
5	Gray	Not used
6	Pink	Not used
7	Blue	0V DC
8	Red	Not used

- Single-Ended Cable for Receiver (F39-JD□A-D, sold separately)

(Unit: mm)

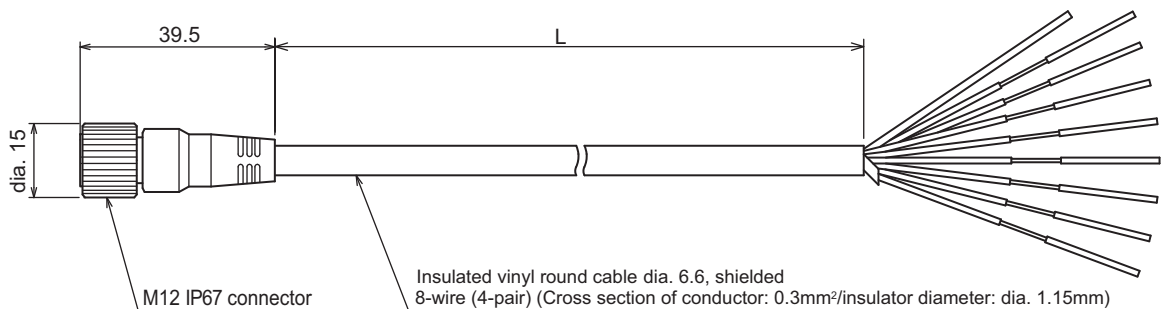

<Internal wiring diagram>

Connected to Power Cable or Double-Ended Cable



Female

1	White	OSSD 2
2	Brown	+24 VDC
3	Black	OSSD 1
4	Yellow	AUX
5	Gray	Not Used
6	Pink	Not Used
7	Blue	0 VDC
8	Red	EDM

Emitter cable (Gray)	Receiver cable (Black)	L (m)
F39-JD3A-L	F39-JD3A-D	3
F39-JD7A-L	F39-JD7A-D	7
F39-JD10A-L	F39-JD10A-D	10
F39-JD15A-L	F39-JD15A-D	15
F39-JD20A-L	F39-JD20A-D	20

4-5-3-2. Double-Ended Cable

- Double-Ended Cable for Emitter: Cable for extension (F39-JD□B-L, sold separately)

(Unit: mm)

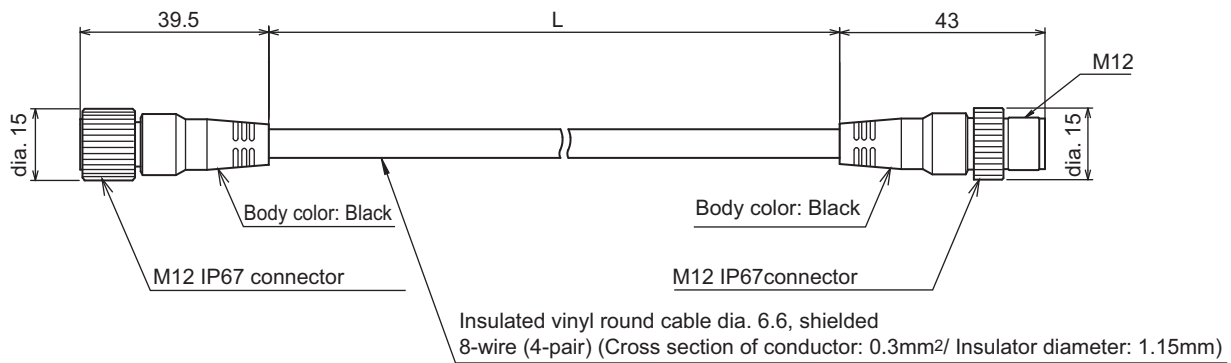

<Internal wiring diagram>



Female

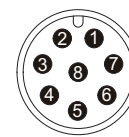
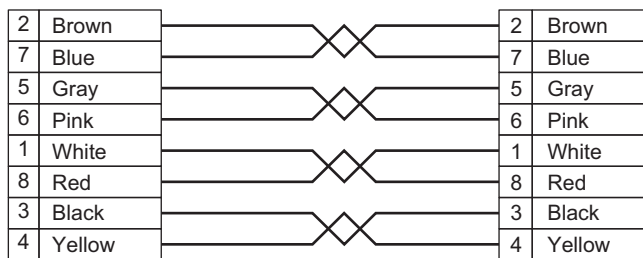

Male

Twisted pair wires are brown and blue, gray and pink, white and red, and black and yellow.

- Double-Ended Cable for Receiver: Cable for extension (F39-JD□B-D, sold separately)
(Unit: mm)

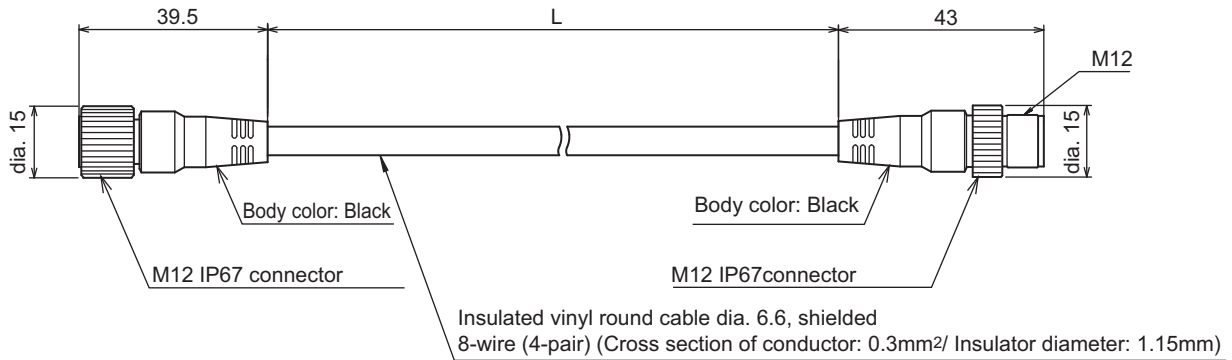

<Internal wiring diagram>

Connected to Power Cable or Double-Ended Cable

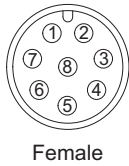

2	Brown
7	Blue
5	Gray
6	Pink
1	White
8	Red
3	Black
4	Yellow

Connected to Single-Ended Cable, or Double-Ended cable



2	Brown
7	Blue
5	Gray
6	Pink
1	White
8	Red
3	Black
4	Yellow

Twisted pair wires are brown and blue, gray and pink, white and red, and black and yellow.

Emitter cable (Gray)	Receiver cable (Black)	L (m)
F39-JDR5B-L	F39-JDR15B-D	0.5
F39-JD1B-L	F39-JD1B-D	1
F39-JD3B-L	F39-JD3B-D	3
F39-JD5B-L	F39-JD5B-D	5
F39-JD7B-L	F39-JD7B-D	7
F39-JD10B-L	F39-JD10B-D	10
F39-JD15B-L	F39-JD15B-D	15
F39-JD20B-L	F39-JD20B-D	20

If the length of the F39-JD□A Single-Ended Cable is insufficient, use 1 or more F39-JD□B Double-Ended Cables to extend the length, as required. The total cable extension length of the power cable must be 100 m max.

<Connection example>

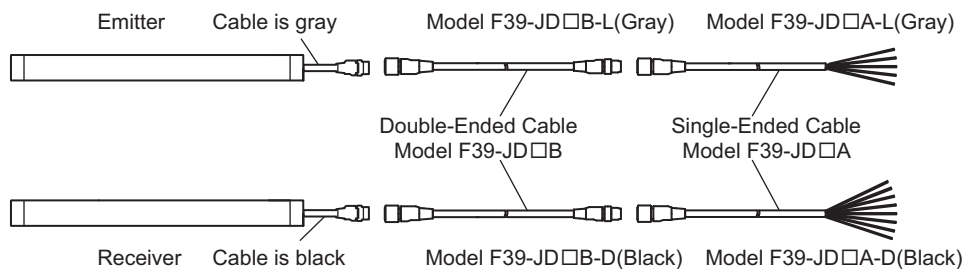

4-5-3-3. Cascading Cable

- Cascading Cable for Emitter (F39-JGR2WTS-L, sold separately)

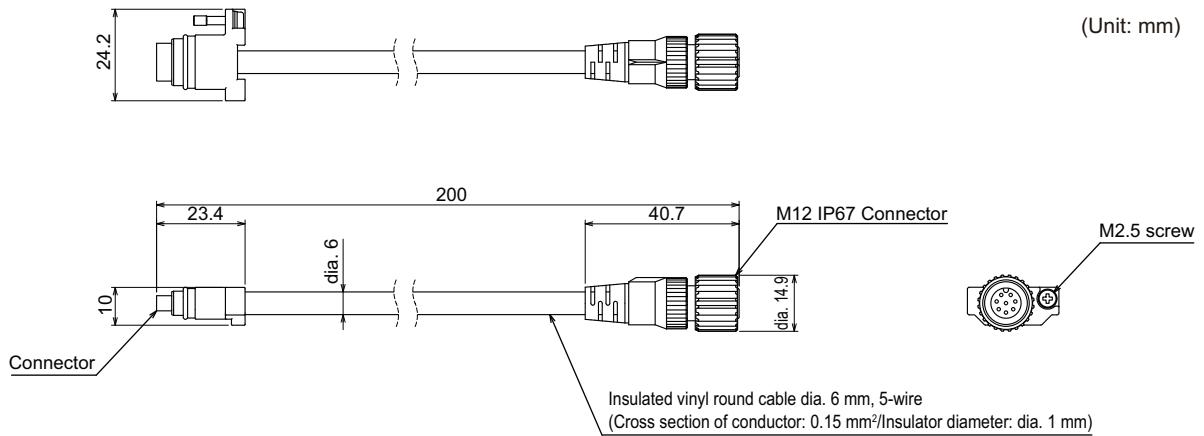

- Cascading Cable for Receiver (F39-JGR2WTS-D, sold separately)

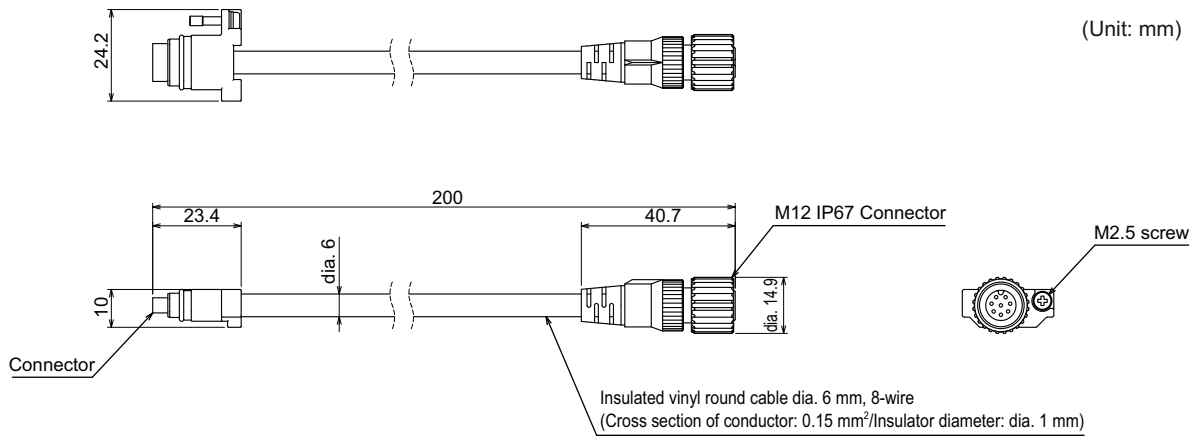

Set model name	Emitter cable (Gray)	Receiver cable (Black)	L (m)
F39-JGR2WTS	F39-JGR2WTS-L	F39-JGR2WTS-D	0.2

If the length of the Cascading Cable is insufficient, connect the F39-JD□B Double-Ended Cable between the power cable of the F3SG-R and the F39-JGR2WTS Cascading Cable, as required. (Cable length between sensors: 10 m max.)

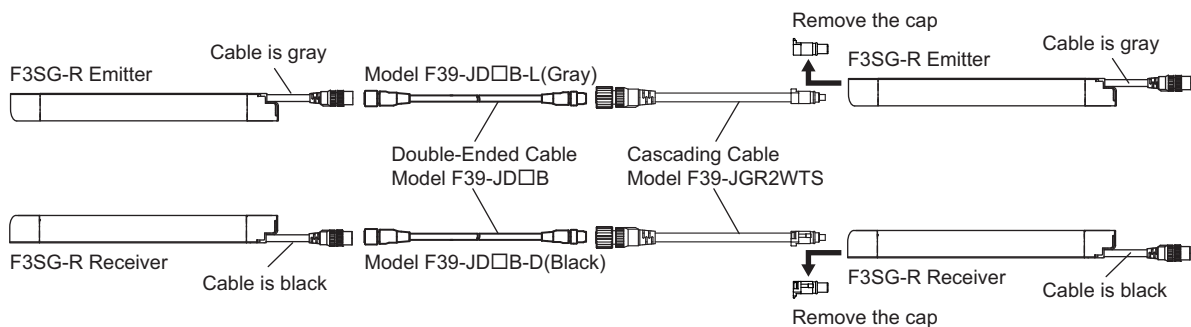

4-5-3-4. Extending Cable Length with Commercially Available Cable

When you need to use a cable that is not specified by OMRON, use a cable that satisfies the following specifications.

1. Emitter and Receiver: 8-wire
2. 0.3 mm² or larger, conductor resistance 0.058 ohms/m max.
3. 24 VDC and 0 VDC lines must be used as twisted-pair lines.



CHECK!

Do not use cables in the same conduit as high voltage or electric power lines.

4-5-4. Functional Earth Connection

The F3SG-R operates properly without functional earth connection in a general industrial environment. If the F3SG-R fails due to electrical noise, connecting the F3SG-R to the functional earth may work to prevent the noise. It is recommended the functional earth terminal of the F3SG-R be connected to functional earth cables. Connection with protective earth cables may cause the F3SG-R to fail due to a noise level of the environment.

When you connect the F3SG-R with the functional earth, connect an earth cable to the functional earth terminals, as shown below.

The size of the screws of the terminals is M3. Make sure to use crimp terminals that fits the size.

The earth cable must have a cross section of 1 mm² or more with conductor resistance of 0.058 ohms/m or less and a length of 20 m or less.

Bottom view of F3SG-R

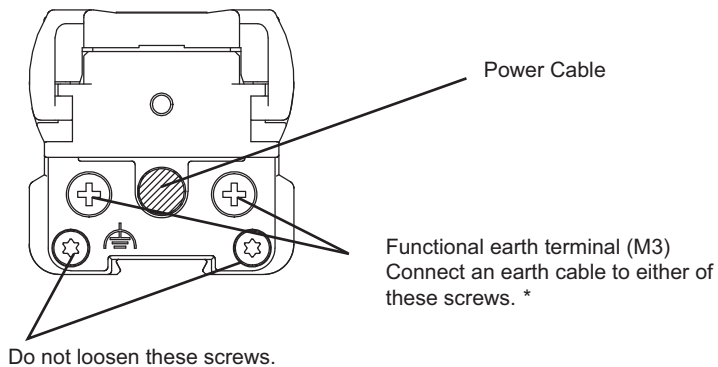

Do not loosen these screws.

* Select either of the terminals of the emitter and receiver according to your environment.

Chapter 5 Input/Output Circuit and Applications

5-1. Input/Output Circuit	78
5-1-1. Entire Circuit Diagram	78
5-1-2. Input Circuit Diagram by Function	80
5-2. Wiring Examples	81
5-2-1. Standalone F3SG-R using PNP Outputs	81
5-2-2. Standalone F3SG-R using NPN Outputs	82
5-3. Connectable Safety Control Units	83

5-1. Input/Output Circuit

5-1-1. Entire Circuit Diagram

The entire circuit diagram of the F3SG-R is shown below.

The numbers in the circles indicate the connector's pin numbers.

■ PNP Output

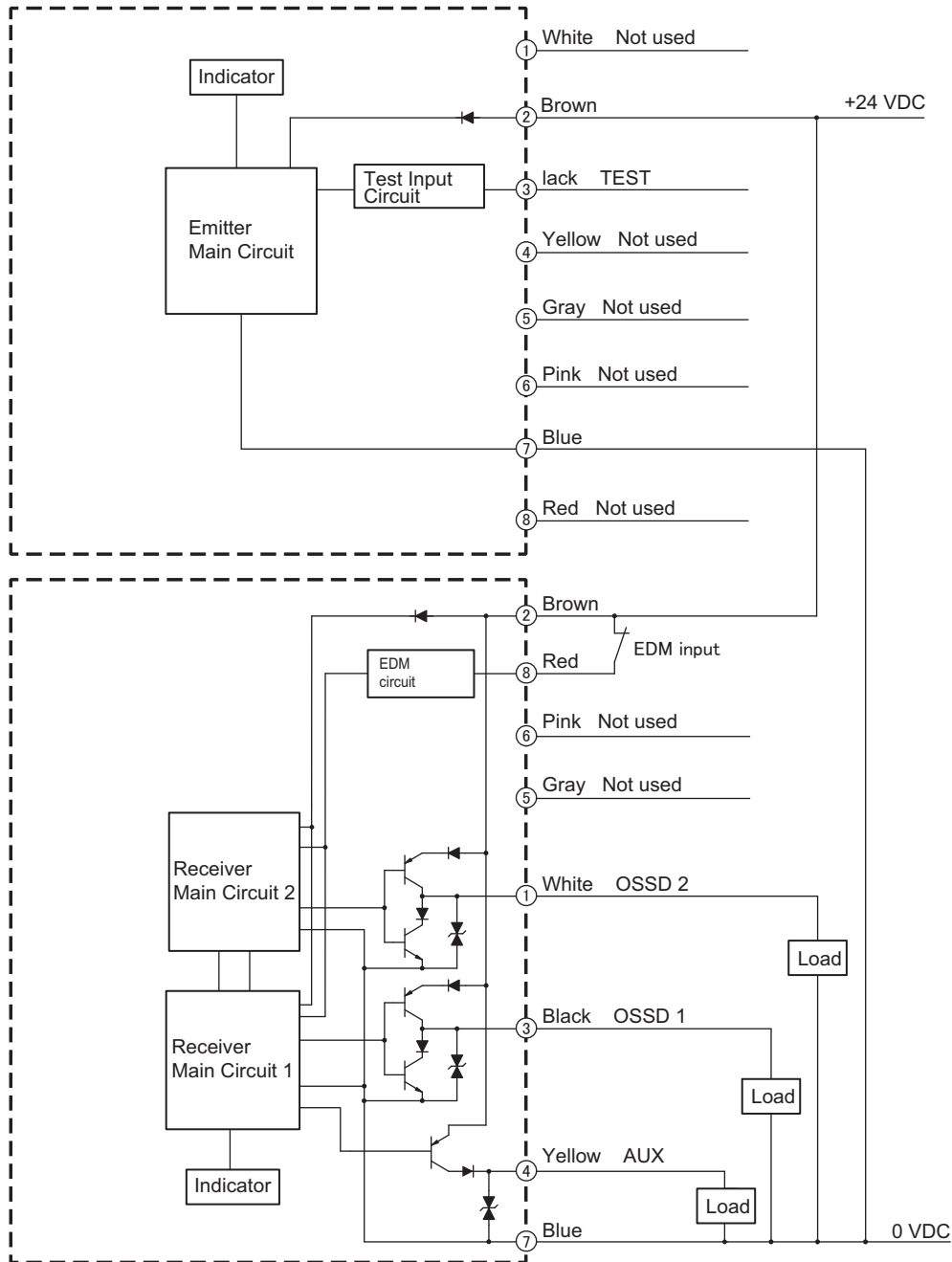

■ NPN Output

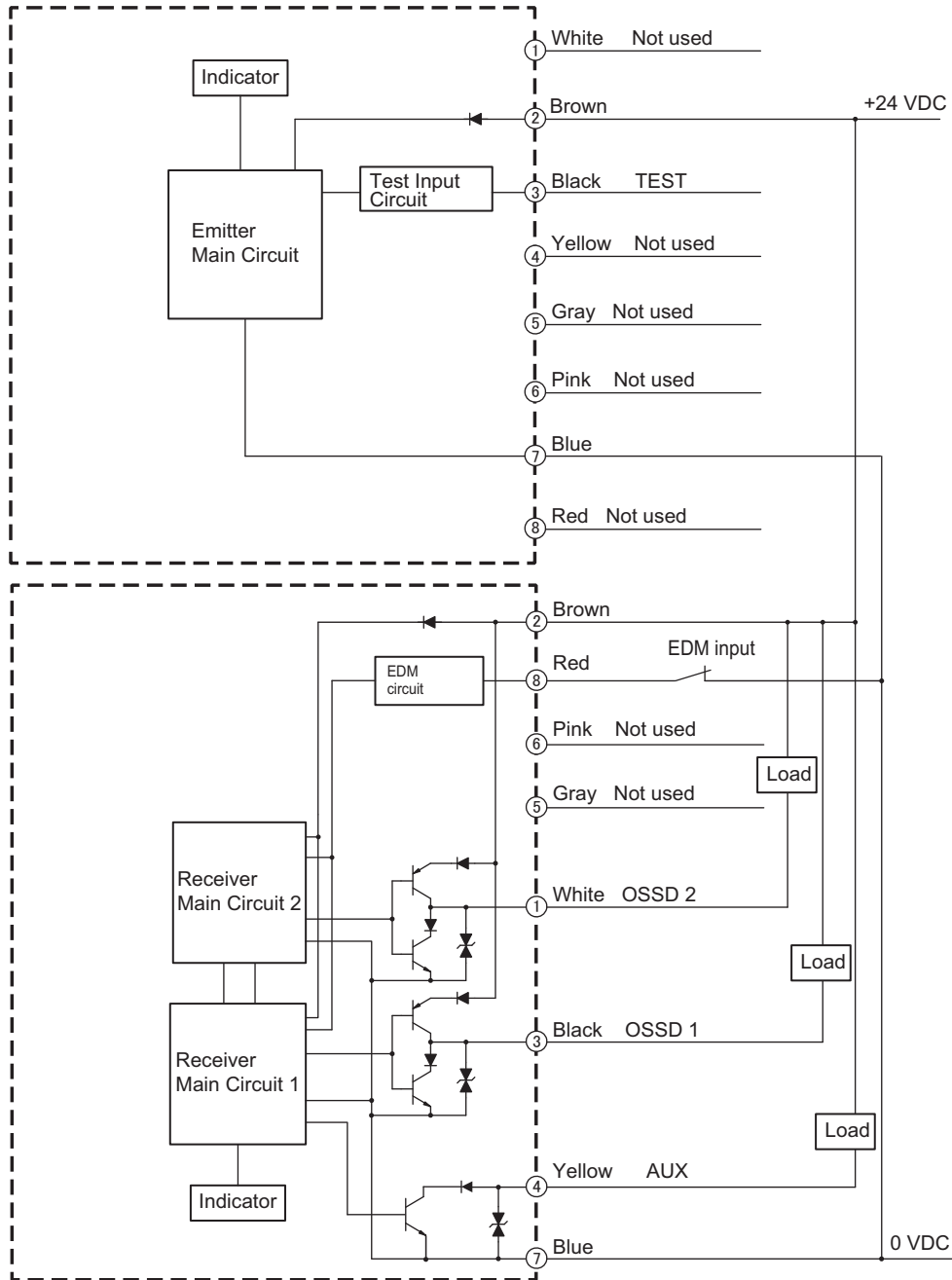

5-1-2. Input Circuit Diagram by Function

The input circuit diagrams of by function are shown below.

■ 24V Inactive

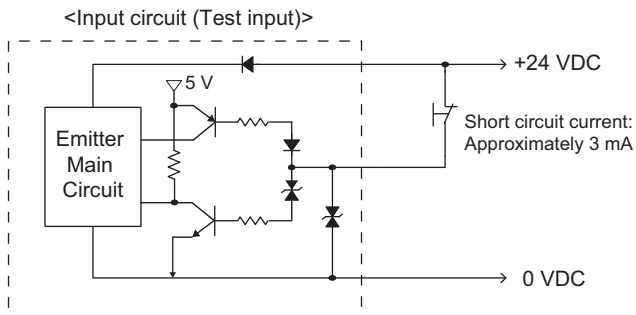

■ PNP Output

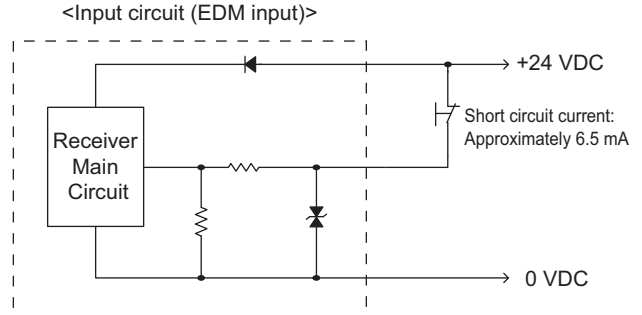

■ 0V Inactive

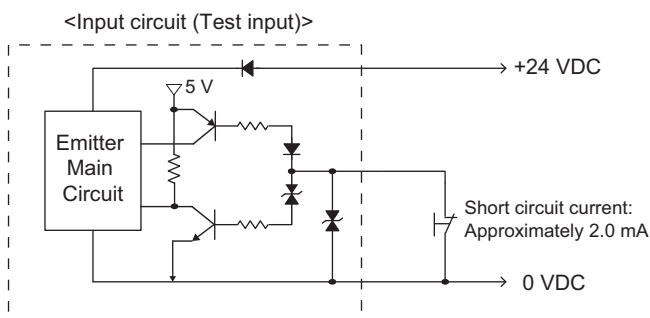

■ NPN Output

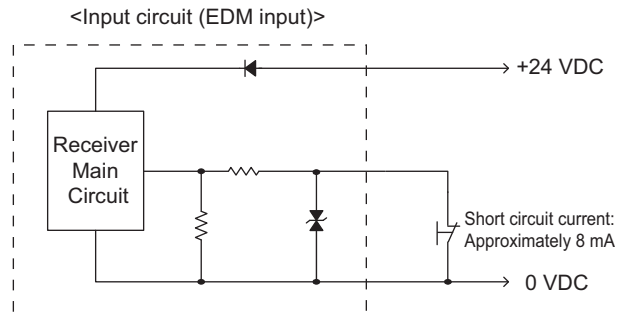

*Short circuit current: 5mA (Reset input), 3mA (Muting inputs A/B)

5-2. Wiring Examples

Examples of a motor control system using the F3SG-RA are shown below. This chapter shows examples equivalent to up to PLe, Category 4 (ISO13849-1).

5-2-1. Standalone F3SG-R using PNP Outputs

■ EDM disabled, External Test unused and PNP Outputs

Example of EDM disabled, PNP outputs and External Test unused.

[DIP Switch settings] *1

	Function	DIP-SW1	DIP-SW2
Receiver	EDM Disabled (factory default setting)	2 <input checked="" type="checkbox"/> ON	2 <input checked="" type="checkbox"/> ON
	PNP (factory default setting)	7 <input checked="" type="checkbox"/> ON	7 <input checked="" type="checkbox"/> ON
Emitter	External Test: 24 V Inactive (factory default setting)	4 <input checked="" type="checkbox"/> ON	

: Indicates a switch position.

Configure functions with the DIP Switches before wiring.

[Wiring Example]

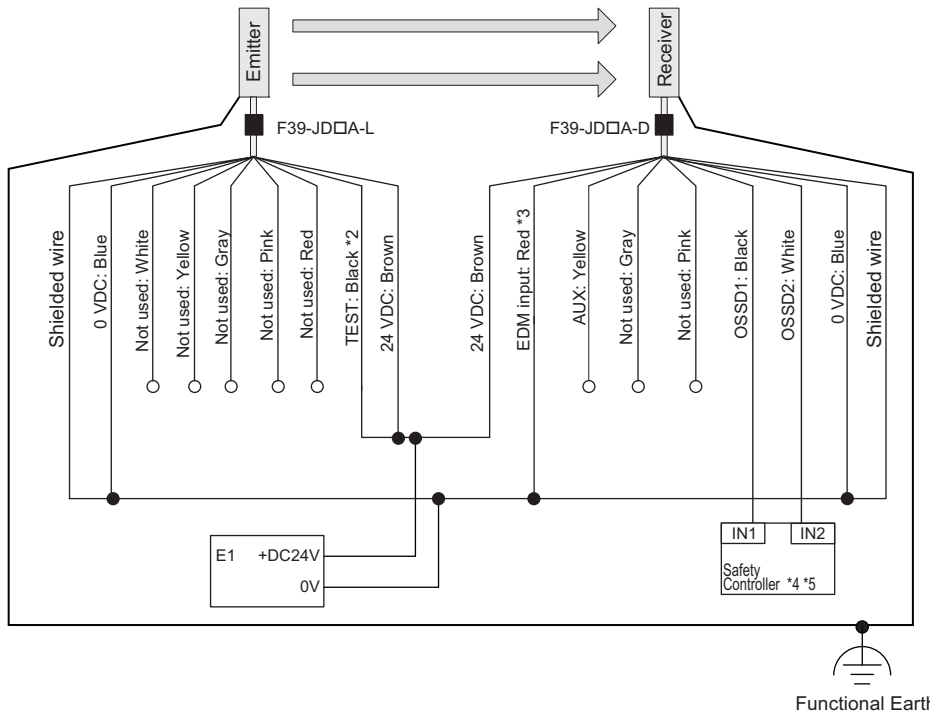

*1. The functions are configurable with DIP Switch. Refer to *Chapter 3 Setting with DIP Switch* for more information.

*2. When the external test function is used, connect to 24V via the test switch (N.C. contact).

*3. Also used for the lockout reset input. When using the lockout reset function, connect to 24V via lockout reset switch (N.C. contact).

*4. Refer to 5-3. *Connectable Safety Control Units* for more information.

*5. The safety controller and the F3SG-RA must share the power supply or be connected to the common terminal of the power supply.

E1: 24VDC power supply (S8VS)

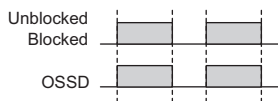

Functional earth connection is unnecessary when you use the F3SG-R in a general industrial environment where noise control or stable power supply is considered. However, when you use the F3SG-R in an environment where there may be excessive noise from surroundings or stable power supply may be interfered, it is recommended the F3SG-R be connected to functional earth.

The wiring examples in later pages do not indicate functional earth. To use functional earth, wire an earth cable according to the example above. Refer to 4-5-4. *Functional Earth Connection* for more information.

5-2-2. Standalone F3SG-R using NPN Outputs

■ EDM enabled, External Test 0V Inactive and NPN Outputs

The following is the example of External Device Monitoring enabled, NPN outputs and External Test in 0 V Active.

[DIP Switch settings] *1

	Function	DIP-SW1	DIP-SW2
Receiver	EDM Enabled	2 <input checked="" type="checkbox"/> ON	2 <input checked="" type="checkbox"/> ON
	NPN	7 <input checked="" type="checkbox"/> ON	7 <input checked="" type="checkbox"/> ON
Emitter	External Test: 0 V Inactive	4 <input checked="" type="checkbox"/> ON	

: Indicates a switch position.

Configure functions with the DIP Switches before wiring.

[Wiring Example]

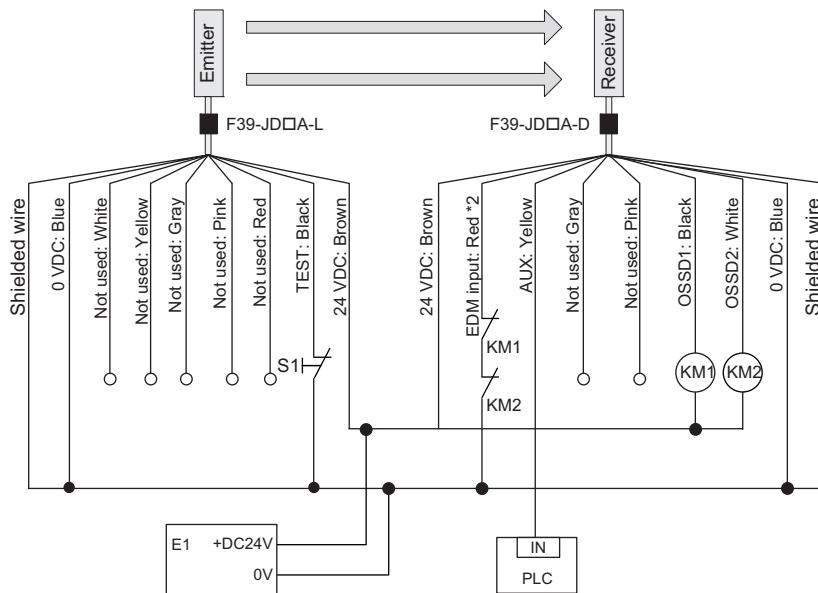

*1. The functions are configurable with DIP Switch. Refer to *Chapter 3 Setting with DIP Switch* for more information on setting the functions by the DIP Switch.

*2. Also used for the lockout reset input. When using the lockout reset function connect to 0V via lockout reset switch (N.C. contact).

S1: External test switch(connect to 0V if a switch is not required)

KM1, KM2: Safety relay with forcibly guided contacts (G7SA) or magnetic contactor

E1: 24VDC power supply (S8VS)

PLC: Programmable controller (Used for monitoring -- not related to safety system)

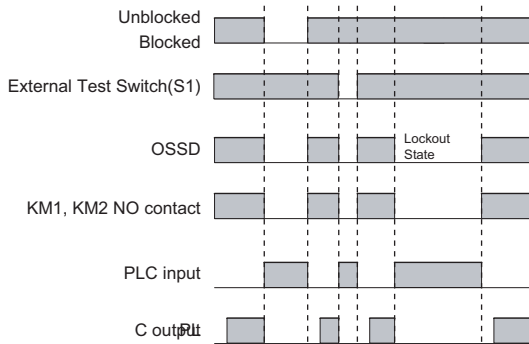

5-3. Connectable Safety Control Units

The F3SG-R with PNP output can be connected to the safety control units listed in the table below.

Connectable Safety Control Units (PNP output)		
G9SA-301	G9SX-AD322-T	G9SP-N10S
G9SA-321	G9SX-ADA222-T	G9SP-N10D
G9SA-501	G9SX-BC202	G9SP-N20S
G9SB-200-B	G9SX-GS226-T15	NE0A-SCPU01
G9SB-200-D		NE1A-SCPU01
G9SB-301-B		NE1A-SCPU02
G9SB-301-D		DST1-ID12SL-1
G9SE-201		DST1-MD16SL-1
G9SE-401		DST1-MRD08SL-1
G9SE-221-T□		NX-SIH400
		NX-SID800
		F3SP-T01

The F3SG-R with NPN output can be connected to the safety control unit listed in the table below.

Connectable Safety Control Units (NPN output)
G9SA-301-P

Chapter 6 Checklists

6-1. Pre-Operation Checklists	86
6-2. Maintenance Checklists	88

6-1. Pre-Operation Checklists

WARNING

Make sure Responsible Person tests the operation of the F3SG-R after installation to verify that the F3SG-R operates as intended. Make sure to stop the machine until the test is complete. Unintended function settings may cause a person to go undetected, resulting in serious injury.



After installation, the highest level administrator must use the following checklist to verify the operation, placing a check mark in each of the boxes.

6-1-1. Checklists

6-1-1-1. Installation Condition Check

- The machine itself does not prevent the operation of safety functions such as stopping.
- The hazardous part of a machine cannot be reached without passing through the detection zone of the F3SG-R.
- The system is configured so that the F3SG-R can always detect a worker who is working in the hazardous zone.
- The interlock reset switch is installed in a location that provides a clear view of the entire hazardous zone and it cannot be activated from within the hazardous zone.
- Safety distance has been calculated. Calculated distance: $S = (\quad)\text{mm}$
- The actual distance is equal to or greater than the calculated distance. Actual distance = $(\quad)\text{mm}$
- Reflective surfaces are not installed in prohibited zones.
- Not installed in a retro-reflective configuration.
- It is not used in flammable or explosive atmosphere.

6-1-1-2. Wiring Check Before Power Is Turned ON

- Power supply unit must be dedicated to F3SG-R and other devices for electrical-detection protective function of F3SG-R such as safety controller, and must not be connected to other devices. It must have tolerance against total rated current of devices if it is connected to multiple devices.
- The power supply unit is a 24 VDC unit that conforms to the EMC Directive, Low-voltage Directive, and output holding time specifications.
- The power supply polarity is not connected in reverse.
- Emitter/receiver cables are properly connected to the respective emitters/receivers.
- Double insulation is used between I/O lines and the hazard potential (commercial power supplies, etc.).
- When using PNP output, the outputs are not short-circuited to +24 VDC line. When using NPN output, the outputs are not short-circuited to 0 V line.
- When using PNP output, loads are not connected to +24 VDC line. When using NPN output, loads are not connected to 0 V line.
- All lines are not connected to commercial power source.
- F3SG-R's power supply connector and series connection connector must not be attached upside down.
- Model of emitter and receiver must be the same.
- When 2 or more F3SG-R systems are used, they are in cascade connection or prevented from mutual interference with each other.
- On a secondary sensor farthest from its power supply, either of the following is attached:
 - End Cap
 - Lamp (F39-LP and F39-BTLP, sold separately)
- Neither connector, cap, or bracket must be loose.
- Auxiliary output must not be used as safety output.
- When using PNP output, 0 V line of the power supply is grounded. When using NPN output, +24 VDC line of the power supply is grounded.
- Wiring must not be bent, cracked, nor damaged.

6-1-1-3. Operation Check While the Machine Is Stopped

- The test rod is not deformed.
Use a test rod with an appropriate diameter for inspection. A test rod is not included in the F3SG-R product package.
- The sensor can detect a test rod wherever it is in the detection zone. In other words, when a test rod is inserted into the detection zone, the Stable-state indicator turns OFF and the ON/OFF turns red.
To check detection, move the test rod as shown in the diagram below.

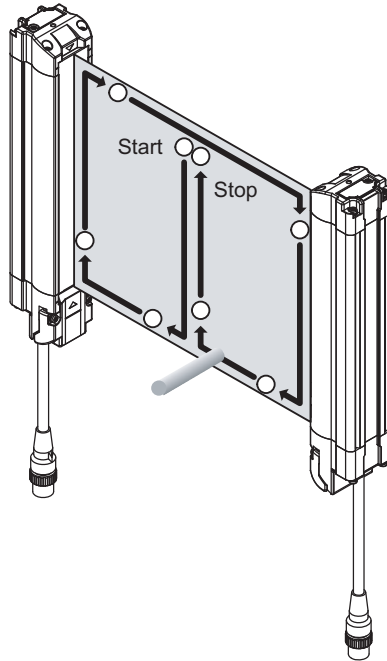

- When the external test function is used:
When 24 V Inactive is enabled by the DIP Switch, the ON/OFF indicator turns red when the TEST line is short-circuited to 0 to 1.5 V or is open.
When 0 V Inactive is enabled by the DIP Switch, the ON/OFF indicator turns red when the TEST line is short-circuited to 9 V to V_s or is open.
- When the external device monitoring function is used:
When the external device monitoring is open the ON/OFF indicator remains red regardless of the beam state of the F3SG-R.

6-1-1-4. Checking that Hazardous Parts Stop While the Machine Operates

- The hazardous parts stop immediately when a test rod is inserted into the detection zone at 3 positions: "directly in front of the emitter", "directly in front of the receiver", and "between the emitter and receiver". (Use the appropriate test rod.)
- The hazardous parts remain stopped as long as the test rod is in the detection zone.
- The hazardous parts stop when the power of the F3SG-R is turned OFF.
- The actual response time of the whole machine is equal to or less than the calculated value.

6-2. Maintenance Checklists

⚠ WARNING

Perform daily and 6-month inspection for the F3SG-R. Otherwise, the system may fail to work properly, resulting in serious injury.



Do not try to disassemble, repair, or modify this product. Doing so may cause the safety functions to stop working properly.



To ensure safety, keep a record of the inspection results.

When the user is a different person from those who installed or designed the system, he/she must be properly trained for maintenance.

6-2-1. Checklists

6-2-1-1. Inspection at Startup and When Changing Operators

- There is no approach route other than through the detection zone of the F3SG-R.
- Part of the operator's body always remains in the detection zone of the F3SG-R when working around the machine's hazardous part.
- The actual safety distance is equal to or greater than the calculated value.
- There must be no dirt on or damage to the optical surface or spatter protection cover (F39-HGA, sold separately) of the F3SG-R.
- When 24 V Inactive is enabled by the DIP Switch, ON/OFF indicator turns red when the TEST line is short-circuited to 0 to 1.5 V or is open. When 0 V Inactive is enabled by the DIP Switch, ON/OFF indicator turns red when the TEST line is short-circuited to 9 V to Vs or is open.
- The test rod is not deformed.
- Nothing should exist in the detection zone and the Stable-state indicator must turn ON at power on.
- The test rod is detected when it is moved around in the detection zone as shown in the diagram below. In other words, when a test rod is inserted into the detection zone, the Stable-state indicator turns OFF and the ON/OFF indicator turns red.

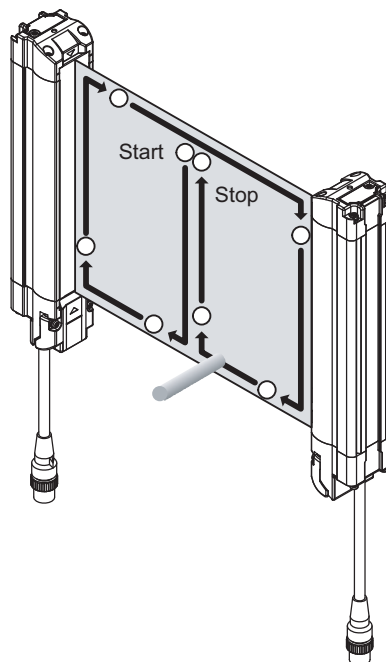

Confirm that hazardous parts should stop while the machine is operating, as shown below.

- Neither connector, cap, or bracket must be loose.

6-2-1-2. Checking that Hazardous Parts Stop While the Machine Operates

- The hazardous parts are movable when nothing is in the detection zone.
- The hazardous parts stop immediately when a test rod is inserted into the detection zone at 3 positions: "directly in front of the emitter", "directly in front of the receiver", and "between the emitter and receiver". (Use the appropriate test rod.)
- The hazardous parts remain stopped as long as the test rod is in the detection zone.
- The hazardous parts stop when the power of the F3SG-R is turned OFF while nothing is in the detection zone.

6-2-1-3. Items to Inspect Every 6 Months or When Machine Settings Are Changed

In addition to inspection item at operation start, following items must also be verified.

- The outputs of the F3SG-R and the machine are properly wired.
- The total number of times that the control relays/contactors have switched is significantly lower than their design lives.
- There is no ambient light.
- When the configuration of the cascade connection is changed, either of the following is attached on a secondary sensor farthest from its power supply:
 - End Cap
 - Lamp (F39-LP and F39-BTLP, sold separately)
- When using PNP output, 0 V line of the power supply is grounded. When using NPN output, +24 VDC line of the power supply is grounded.
- Wiring must not be bent, cracked, nor damaged.

Chapter 7 Appendix

7-1. Troubleshooting	92
7-1-1. Lockout State	92
7-1-2. Warning	96
7-2. Optional Accessories(Sold Separately)	98
7-3. Glossary	104
7-4. Revision History	105

7-1. Troubleshooting

■ F3SG-RA Series

- 1. Test indicator (Green)
- 2. LONG indicator (Green)
- 3. Power indicator (Green)
- 4. Lockout indicator (Red)

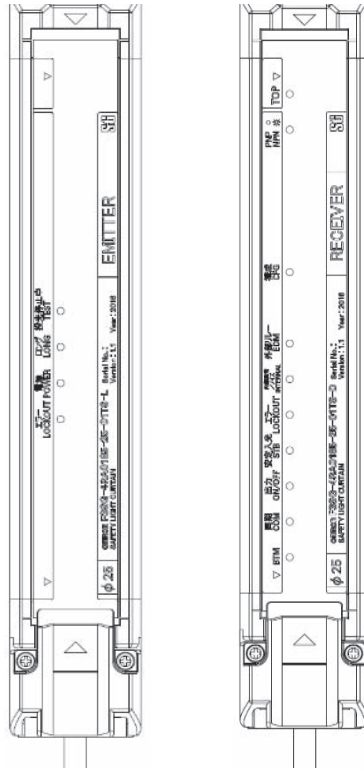

- 1. TOP indicator (Blue)
- 2. NPN indicator (Green)
- 3. CFG indicator (Green)
- 4. EDM indicator (Green)
- 5. INTERNAL indicator (Red)
- 6. LOCKOUT indicator (Red)
- 7. STB indicator (Green)
- 8. ON/OFF indicator (Green / Red)
- 9. COM indicator (Green)
- 10. BTM indicator (Blue)

LED Blinking Pattern:

The timing chart below shows the blinking frequency of the LED blinking patterns (blinking once through second times) described in the following pages.

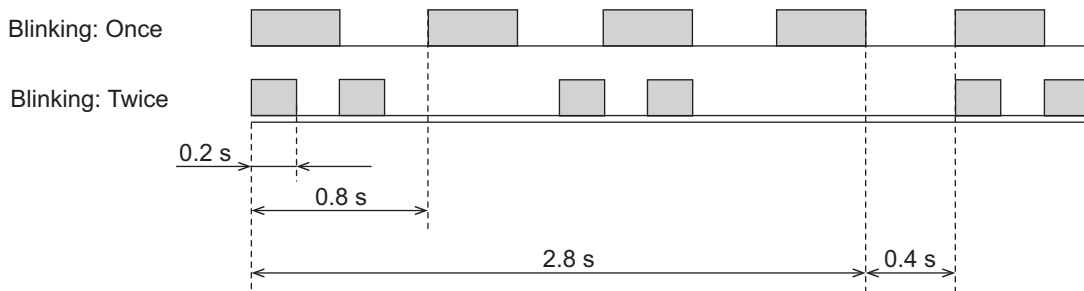

7-1-1. Lockout State

7-1-1-1. Description

If F3SG-R detects any failure, it keeps safety output OFF and transitions to lockout state. Under lockout state, the lockout indicators blink or are ON and other indicators blink based on the failure. Solve the problems based on the table below.

Eliminate the cause of the problem. Then turn the power ON again or reset the lockout state by providing a lockout reset input to restart the F3SG-R.

7-1-1-2. Troubleshooting

Identify an error according to the combination of the indicators when the error occurs. See the following troubleshooting tables to take measures.

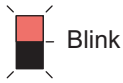

<Indicator status at lockout: Receiver>

Combination of Indicators and Error Description

[Error Description]







LOCKOUT Blinking Once	TOP		Cap error Other sensor error
	CFG		Cascading configuration error
	EDM		External device monitoring error
	INTERNAL		Internal error
	ON OFF		Safety output error
	COM		Communication error
	BTM		DIP Switch setting error
LOCKOUT Blinking Twice	ON OFF		Safety output error due to power supply voltage or noise
	COM		Communication error due to power supply voltage or noise
	INTERNAL		Internal error due to power supply voltage or noise

<Indicator status at lockout: Emitter>

Combination of Indicators and Error Description

[Error Description]

LOCKOUT Blinking Once	LONG		DIP Switch setting error Operating range selection setting error
	POWER		Other sensor error Cascading configuration error Internal error Communication error
LOCKOUT Blinking Twice	POWER		Internal or Communication error due to noise

Description	Error code	Cause and measures
Cap error	4F	A cap may be detached. Attach the cap properly.
Other sensor error	38	Other sensor being cascaded caused an error. Check the indicator of the sensor.
Cascading configuration error	39, 3A, 3B	The cascading cable may be short-circuited, broken, or disconnected. Check that the cascading cable should be tightly connected. If the cascading cable is broken, replace it.
		The number of connected sensors or beams may have exceeded the maximum value due to cascading. Check the configuration.
External device monitoring error	52	Relay may be welded. Replace the relay.
		The relay and EDM wire may not be wired correctly. Check the wiring with the relay.  Chapter 4 Wiring/Installation
		The relay response time may be exceeding the allowable delay time. Change the allowable delay time or replace the relay with one that has an appropriate response time.  2-8. External Device Monitoring (EDM)  Chapter 4 Wiring/Installation
Safety output error	60, 6B, 6C	Safety output lines may be short-circuited to each other or another signal line may be short-circuited to the safety output line. Wire the safety output lines properly.  Chapter 4 Wiring/Installation
Communication error	30, 31, 32	The communication line or other wiring may be broken or short-circuited. Check the cables for cascading or extension cables.
		If the wiring is extended with cables other than specified, the cables used for extension may not have performance equivalent or greater than the specified cables. Use cables with the same performance or more than the specified cables.  Chapter 4 Wiring/Installation
DIP Switch setting error	E7, E8	A DIP Switch setting may have been changed during operation. Check if a DIP Switch setting was changed or not.
		Settings of two DIP Switches of a receiver may be unmatched. Check if two DIP Switches of a receiver are matched.
Operating range selection setting error	--	The setting of the operating range selection may be incorrect. • Check if the Operating Range Selection of the DIP Switch is properly set.  Chapter 3 Setting with DIP Switch  2-10. Operating Range Selection

Description	Error code	Cause and measures
Safety output error due to power supply voltage or noise	19	<p>The power supply voltage may have dropped temporarily when the F3SG-R is in operation. Check for temporary power supply voltage drop (by about 12 VDC) by the influence of the inductive load, etc. If the exclusive power supply is not used, check the power consumption of other connected devices for enough capacity.</p> <p>Power supply voltage may be outside the rated range. Connect the F3SG-R to a 24 VDC±20% power supply voltage.</p> <p>Voltage fluctuation may have occurred due to insufficient power supply capacity. Replace the power supply with one that has a larger capacity.</p> <p>Instantaneous break or instantaneous stop may have occurred due to power sharing with other devices. Do not share the power supply with other devices. Connect the F3SG-R to a power supply that is dedicated to electro-sensitive protective devices for electro-sensitive protective equipment such as the F3SG-R, safety controller, etc.</p>
	1A	<p>Effect of noise may be excessive.</p> <p>If other devices using the same power supply generate noise, do not share the same power supply with other devices, and use a separate power supply exclusively for the safety components.</p> <p>The inductive noise tends to be induced especially if the power supply line of the machine guarded and the power supply line of the F3SG-R are arranged in parallel. Arrange the exclusive power supply near the F3SG-R or lay the power supply line of the F3SG-R away from the power supply line of the machine guarded.</p> <p>If the power supply for the F3SG-R is located near the power supply of the machine guarded and it uses the same ground, it is subject to the influence of common mode noise from the ground. Separate the grounding point or use it as the exclusive ground.</p> <p> 4-5-4. Functional Earth Connection</p>
Communication error due to power supply voltage or noise	19	<p>The power supply voltage may have dropped temporarily when the F3SG-R is in operation. Check for temporary power supply voltage drop (by about 12 VDC) by the influence of the inductive load, etc. If the exclusive power supply is not used, check the power consumption of other connected devices for enough capacity.</p>
	1A	<p>Communication error may have occurred due to noise. Check the noise level in the environment.</p>
Internal error due to power supply voltage or noise	19, 1A	<p>The internal circuitry may be defective due to power supply voltage or noise. Check the noise level in the environment. Make sure that the power supply voltage is 24 VDC±20%. If the indicator still shows this error, replace the F3SG-R.</p>
Internal or communication error due to noise	--	<p>The internal circuitry may be defective due to noise. Check the noise level in the environment.</p>
		<p>Communication error may have occurred due to noise. Check the noise level in the environment.</p>
Internal error	Error code other than those above	<p>An error may have occurred in the internal circuit. Replace the F3SG-R.</p>

7-1-2. Warning

7-1-2-1. Description

If an error is detected that prevents the F3SG-R to continue normal operation, the STB indicator blinks to notify warning information according to the error. The F3SG-R continues normal operation. When the cause of the error is solved, the F3SG-R automatically recovers from the warning status.

7-1-2-2. Troubleshooting

Identify an error according to the combination of the indicators when the error occurs. See the following troubleshooting tables to take measures.

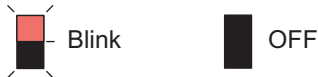

<Indicator status at warning: Receiver>

Combination of Indicators and Error Description

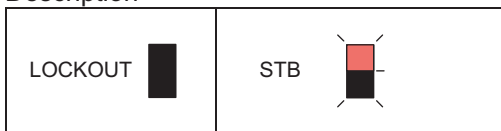

[Warning Description]

Malfunction due to ambient light or vibration

<Indicator status at warning: Emitter>

None

Description	Warning code	Cause and measures
Malfunction due to ambient light or vibration	11	<p>Malfunction may have occurred due to ambient light or instantaneous beam misalignment from vibration. Check the installation condition. Take necessary measures against mutual interference according to "4-1-4. Mutual Interference Prevention".</p> <p> 4-1-4. Mutual Interference Prevention</p>

7-1-3. Troubles other than in Lockout State

Shown below are actions to take when F3SG-R does not work properly while no lockout occurred and no error is displayed.

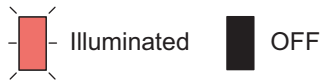

<Indicator status: Receiver>

Combination of Indicators and Error
Description

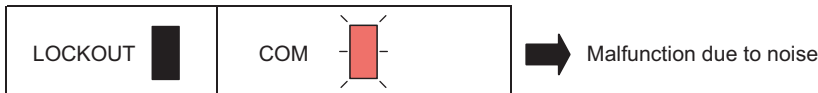

<Indicator status: Emitter>

None

COM indicator is illuminated with all beams of F3SG-R blocked or light emission stopped.

Description	Cause and measures
Malfunction due to noise	<p>Effect of noise may be excessive.</p> <p>If other devices using the same power supply generate noise, do not share the same power supply with other devices, and use a separate power supply exclusively for the safety components.</p> <p>The inductive noise tends to be induced especially if the power supply line of the machine guarded and the power supply line of the F3SG-R are arranged in parallel.</p> <p>Arrange the exclusive power supply near the F3SG-R or lay the power supply line of the F3SG-R away from the power supply line of the machine guarded.</p> <p>If the power supply for the F3SG-R is located near the power supply of the machine guarded and it uses the same ground, it is subject to the influence of common mode noise from the ground. Separate the grounding point or use it as the exclusive ground.</p> <p> 4-5-4. Functional Earth Connection</p>

7-2. Optional Accessories(Sold Separately)

Single-Ended Connector Cable (2 cables per set, for emitter and receiver)

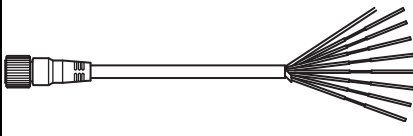
Appearance	Model	Cable length	Specifications
	F39-JD3A	3 m	M12 connector (8-pin) - 8 wires + Shield
	F39-JD7A	7 m	
	F39-JD10A	10 m	
	F39-JD15A	15 m	
	F39-JD20A	20 m	

Double-Ended Connector Cable (2 cables per set, for emitter and receiver)

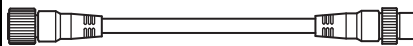
Appearance	Model	Cable length	Specifications
	F39-JDR5B	0.5 m	M12 connector (8-pin) - M12 connector (8-pin)
	F39-JD1B	1 m	
	F39-JD3B	3 m	
	F39-JD7B	7 m	
	F39-JD10B	10 m	
	F39-JD15B	15 m	
	F39-JD20B	20 m	

Cascading Cable (two cables per set, for emitter and receiver)

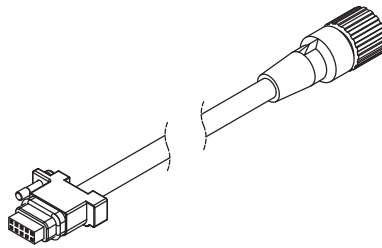
Appearance	Model	Cable length	Specifications
	F39-JGR2WTS	0.2 m	Cap (8-pin) - M12 connector (8-pin)

Lamp

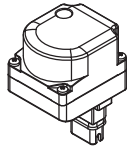
Appearance	Model	Remarks
	F39-LP	Used for the receiver. Material: PC (Lighting element) PBT (Other body parts)

Interface Unit

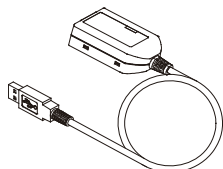
Appearance	Model	Remarks
	F39-GIF	A dedicated cable is also supplied.

Bluetooth® Communication Unit

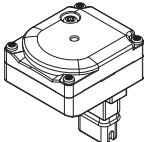
Appearance	Model	Remarks
	F39-BT	Used for the receiver. Material: PBT

Lamp and Bluetooth® Communication Unit

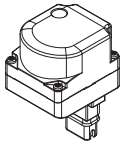
Appearance	Model	Remarks
	F39-BTLP	Used for the receiver. Material: PC (Lighting element) PBT (Other body parts)

End Cap

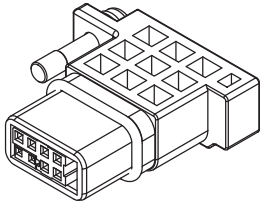
Appearance	Model	Remarks
	F39-CNM	Housing color: Black For both F3SG-R emitter and receiver (Attached to the F3SG-RA. The End Cap can be purchased if lost.)

Laser Alignment Kit

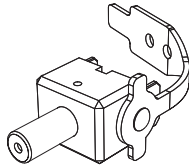
Appearance	Model	Application	Remarks
	F39-PTG	You can attach this to F3SG-R. The laser light assists coarse beam alignment.	Red semiconductor laser (wavelength 650 nm, 1 mW max., JIS Class 2, IEC Class 2, FDA Class II)

Standard Fixed Bracket

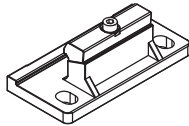
Appearance	Model	Application	Remarks
	F39-LGF	Bracket to mount the F3SG-R. Side mounting and backside mounting possible. Beam alignment after mounting not possible.	Number of brackets when purchased as spare: 2 brackets per set F39-LGF is included in the F3SG-R product package. The number of brackets included depends on protective height of the F3SG-R. - Protective height and number of brackets included: Less than 1,280 mm: 2 sets 1,280 mm or longer and up to 2,270 mm: 3sets 2,350 mm or longer and up to 2,510 mm: 4 sets

Standard Adjustable Bracket

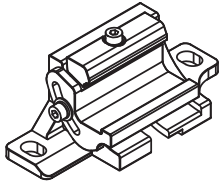
Appearance	Model	Application	Remarks
	F39-LGA	Bracket to mount the F3SG-R. Beam alignment after mounting possible. Side mounting and backside mounting possible.	2 brackets per set.

Top/Bottom Adjustable Bracket

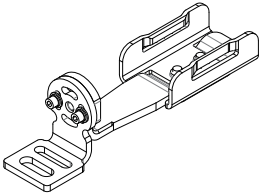
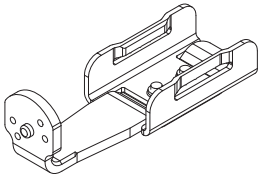
Appearance	Model	Application	Remarks
	F39-LGTB	Bracket to mount the F3SG-R. Use this bracket at the top and bottom positions of the F3SGR. Beam alignment after mounting possible. Side mounting and backside mounting possible.	4 brackets per set. This bracket is not useable together with the Standard Fixed Bracket. When it is necessary to use it with another bracket, only the combination with the Standard Adjustable Bracket is possible. Refer to 4-4-3-3. <i>Mounting with Top/Bottom Adjustable Brackets (F39-LGTB)</i> for more information on parts names of this bracket.
	F39-LGTB-1	F39-LGTB-1 does not come with the parts to mount to a wall surface (Top/Bottom Bracket (3) and Screw (1)). Please prepare these parts according to your device.	

Test Rod

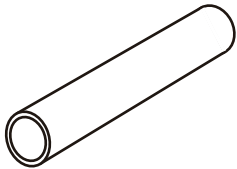
Appearance	Model	Diameter
	F39-TRD25	25 mm dia.



To check operation before use, purchase and use the test rod.

CHECK!

Spatter Protection Cover (two pieces per set, common for emitter/receiver)

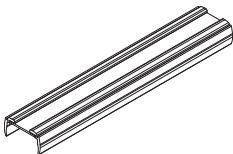
Appearance	Model	Remarks
	F39-HGA□□□□ (for F3SG-RA)	Please note the following: <ul style="list-style-type: none"> The operating range of the F3SG-R attached with the Spatter Protection Cover is 10% shorter than the rating. The Spatter Protection Cover extends over the DIP Switch cover of the F3SG-RA. Be sure to use the Spatter Protection Cover only after all required settings are made to the DIP Switch. Material: PC (Transparent cover), ABS (Side wall), Stainless steel (Bracket), Aluminum adhesive tape (Fixing Sticker)

Mirrors (Operating range becomes 12% shorter than the rating)

Appearance	Model	Remarks
	F39-MLG□□□□ □: Dimension L (mm) F39-MLG0406 F39-MLG0610 F39-MLG0711 F39-MLG0914 F39-MLG1067 F39-MLG1219 F39-MLG1422 F39-MLG1626 F39-MLG1830 F39-MLG2134	Dimension L is the length of mirror part. Other dimensions: Width 145 mm, Thickness 32 mm 2 sets of cylinder mounting brackets and four screws are included.

Control Unit

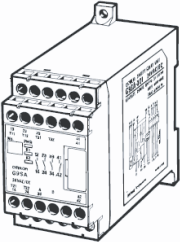
Appearance	Model	Output	Remarks
	G9SA-301	Safety output (relay): NO contact x 3 Auxiliary output (relay): NC contact x 1	<ul style="list-style-type: none"> • An F39-JD□A Single-Ended Cable is required. • An F3SG-R with PNP output can be connected. • A type of 5 N.O. and 1 N.C. contacts is also available.

Control Unit

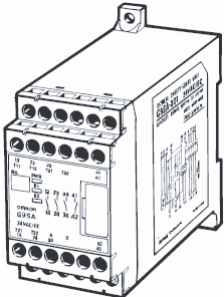
Appearance	Model	Output	Remarks
	G9SA-301-P	Safety output (relay): NO contact x 3 Auxiliary output (relay): NC contact x 1	<ul style="list-style-type: none"> • An F39-JD□A Single-Ended Cable is required. • An F3SG-R with NPN output can be connected.

Control Unit

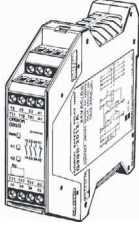
Appearance	Model	Output	Remarks
	G9SB-301-B	Safety output (relay): NO contact x 3 Auxiliary output (relay): NC contact x 1 Auto reset	<ul style="list-style-type: none"> • An F39-JD□A Single-Ended Cable is required. • An F3SG-R with PNP output can be connected. • Thickness of a type of three N.O. and one N.C. contacts is 22.5 mm. • Thickness of a type of two N.O. contacts is 17.5 mm.
	G9SB-301-D	Safety output (relay): NO contact x 3 Auxiliary output (relay): NC contact x 1 Manual reset	
	G9SB-200-B	Safety output (relay): NO contact x 2 Auto reset	
	G9SB-200-D	Safety output (relay): NO contact x 2 Manual reset	

Control Unit

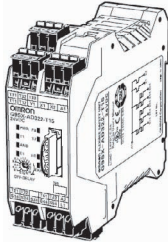
Appearance	Model	Output	Remarks
	G9SX-AD322-T15	Safety output (solid-state): source output (PNP) x 3 (instantaneous), source output (PNP) x 2 (OFF-delayed) Auxiliary output (solid-state): source output (PNP) x 2	<ul style="list-style-type: none"> • An F39-JD□A Single-Ended Cable is required. • An F3SG-R with PNP output can be connected. • 16 patterns of OFF-delayed output for up to 15 seconds can be set. • The OFF-delayed output can be used as instantaneous output by setting it to 0 second. • Can be configured for partial control and total control. • Can be extended to connect a relay unit.

Control Unit

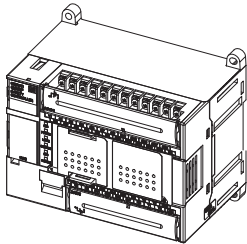
Appearance	Model	Output	Remarks
	G9SP-N10S	Safety output (solid-state): source output (PNP) x 4 Test output (solid-state): source output (PNP) x 4 Standard output (solid-state): source output (PNP) x 4	<ul style="list-style-type: none"> • An F39-JD□A Single-Ended Cable is required. • An F3SG-R with PNP output can be connected.
	G9SP-N10D	Safety output (solid-state): source output (PNP) x 16 Test output (solid-state): source output (PNP) x 6	
	G9SP-N20S	Safety output (solid-state): source output (PNP) x 8 Test output (solid-state): source output (PNP) x 6	

Control Unit

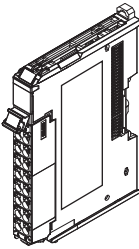
Appearance	Model	Application	Specifications
	NX-SIH400	Safety input (solid-state): sink input (PNP) x 4 Test output (solid-state): source output (PNP) x 2	<ul style="list-style-type: none"> An F39-JD□A Single-Ended Cable is required. An F3SG-R with PNP output can be connected.
	NX-SID800	Safety input (solid-state): sink input (PNP) x 8 Test output (solid-state): source output (PNP) x 2	

Control Unit

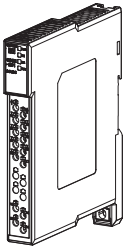
Appearance	Model	Application	Specifications
	G9SE-201	Safety output (relay): NO contact x 2 (instantaneous) Auxiliary output (solid-state): source output (PNP) x 1	<ul style="list-style-type: none"> An F39-JD□A Single-Ended Cable is required. An F3SG-R with PNP output can be connected. For G9SE-221-T□, 16 patterns of OFF-delayed output for up to 5 or 30 seconds can be set.
	G9SE-401	Safety output (relay): NO contact x 4 (instantaneous) Auxiliary output (solid-state): source output (PNP) x 1	
	G9SE-221-T□	Safety output (relay): NO contact x 2 (instantaneous), NO contact x 2 (OFF-delayed) Auxiliary output (solid-state): source output (PNP) x 1	

7-3. Glossary

	Term	Description
A	Allowable delay time	The allowable amount of time difference from when the state of the Safety outputs changes until the state of an external relay changes. The F3SG-R enters the Lockout state if this time is exceeded.
	Auxiliary output	The inverted signal of the safety output is output. This must not be used for safety applications.
E	Effective aperture angle (EAA)	Range of angles in which the F3SG-R can operate.
	External device monitoring function (EDM)	Function to monitor the operation of an N.C. contacts of external relays (or contactors) that control the hazardous zone of a machine, for any malfunctions such as welding.
	External test	Function that stops emission at a specified time to check that the Safety outputs are being properly turned OFF.
L	Lockout	Function to keep the Safety outputs in the OFF state when an error is detected by the F3SG-R.
	Lockout reset	Cancels the lockout state.
	Lower beam(s)	Beams located toward the Power Cable of the F3SG-R.
O	Object resolution (Detection capability)	Minimum size of an object that can be detected in the protective height of the F3SG-R.
	Operating range selection	Function to change the operating range by changing the emission light level of the F3SG-R.
	Output operation mode	Information to be signaled to an output part (Safety output, Auxiliary output).
P	PELV	Protected Extra Low Voltage. A grounded circuit separated by double insulation or equivalent from hazardous voltage. It does not generate voltage that exceeds ELV under normal conditions and under single-fault conditions. Normally, protection against direct contact is required.
	PNP/NPN Selection	Function to select the safety output type between PNP and NPN.
	Primary sensor	Name used for the F3SG-RA to be connected nearest the power supply, when in cascade connection.
R	Response time from ON to OFF	Period of time from when the F3SG-R is blocked until the Safety outputs are turned from ON to OFF.
	Restart Interlock	Function to turn the Safety outputs to the OFF state when the F3SG-RA is blocked and keep this state until a reset signal is received.
S	Safety output (OSSD)	Output to be turned to the ON state when safety is ensured. This can be used for safety applications.
	Safety output information	Information to be signaled to the Auxiliary output or Lamp when the Safety outputs are in the ON state.
	Secondary sensor	Name used for other segments of F3SG-RA's than the primary sensor, when in cascade connection.
	SELV	Safety Extra Low Voltage. An ungrounded circuit separated by double insulation or equivalent from hazardous voltage. It does not generate voltage that exceeds ELV under normal conditions and under single-fault conditions. If the nominal voltage exceeds 25 VAC or 60 VDC, protection against direct contact is required.
	Start interlock	Function to turn the Safety outputs to the OFF state at power-on or recovery from power failure and keep this state until a reset signal is received.
U	Upper beam(s)	Beams located toward the terminal of the F3SG-R.
V	Vs	Power supply voltage value in your usage environment.

7-4. Revision History

A manual revision code appears as a suffix to the manual number at the bottom of the front and back covers of this manual.

Z380-E1-01
↑
Revision No.

Revision symbol	Revision date	Revisions
01	May, 2016	First edition

OMRON Corporation Industrial Automation Company
Kyoto, JAPAN

Contact: www.ia.omron.com

Regional Headquarters

OMRON EUROPE B.V.

Wegalaan 67-69, 2132 JD Hoofddorp
The Netherlands
Tel: (31)2356-81-300/Fax: (31)2356-81-388

OMRON ELECTRONICS LLC

2895 Greenspoint Parkway, Suite 200
Hoffman Estates, IL 60169 U.S.A.
Tel: (1) 847-843-7900/Fax: (1) 847-843-7787

OMRON ASIA PACIFIC PTE. LTD.

No. 438A Alexandra Road # 05-05/08 (Lobby 2),
Alexandra Technopark,
Singapore 119967
Tel: (65) 6835-3011/Fax: (65) 6835-2711

OMRON (CHINA) CO., LTD.

Room 2211, Bank of China Tower,
200 Yin Cheng Zhong Road,
PuDong New Area, Shanghai, 200120, China
Tel: (86) 21-5037-2222/Fax: (86) 21-5037-2200

Authorized Distributor:

© OMRON Corporation 2016. All Rights Reserved.
In the interest of product improvement,
specifications are subject to change without notice.

Cat. No. Z380-E1-01

Printed in Japan
0216(1014)