

**Safety Light Curtain
F3SG-□RR Series**

User's Manual



Original instructions

Introduction

Thank you for purchasing the F3SG-□RR Series Safety Light Curtain (hereinafter referred to as the "F3SG-RR"). This is the instruction Manual describing the use of F3SG-RR. Always heed the following points when using the F3SG-RR:

- Be sure to have F3SG-RR be handled by a "Responsible Person" who is well aware of and familiar with the machine to be installed.
- The term "Responsible Person" used in this Instruction Manual means the person qualified, authorized and responsible to secure "safety" in each process of the design, installation, operation, maintenance services and disposition of the machine.
- It is assumed that F3SG-RR will be used properly according to the installation environment, performance and function of the machine. Responsible Person should conduct risk assessment on the machine and determine the suitability of this product before installation.
- Read this Manual thoroughly to understand and make good use of the descriptions before installing and operating the product.
- Keep this Manual at the place where the operator can refer to whenever necessary.

Trademarks

The Bluetooth® word mark and logos are registered trademarks owned by Bluetooth SIG, Inc. Any use of such marks by Omron is under license. The names of the other companies and products mentioned herein are the trademarks or registered trademarks of their respective owners.

Legislation and Standards

1. The F3SG-RR does not receive type approval provided by Article 44-2 of the Industrial Safety and Health Act of Japan. When using the F3SG-RR in Japan as a "safety system for pressing or shearing machines" prescribed in Article 42 of that law, the machine control system must receive type approval.
2. The F3SG-RR is electro-sensitive protective equipment (ESPE) in accordance with European Union (EU) Machinery Directive Annex V, Item 2.
3. EC/EU Declaration of Conformity
 OMRON declares that the F3SG-RR is in conformity with the requirements of the following EC/EU Directives:
 Machinery Directive 2006/42/EC
 EMC Directive 2014/30/EU
4. Conforming Standards
 - (1) European standards
 EN61496-1 (Type 4 ESPE), EN 61496-2 (Type 4 AOPD), EN61508-1 through -4 (SIL 3),
 EN ISO 13849-1:2015 (PL e, Category 4)
 - (2) International standards
 IEC61496-1 (Type 4 ESPE), IEC61496-2 (Type 4 AOPD), IEC61508-1 through -4 (SIL 3),
 ISO 13849-1:2015 (PL e, Category 4)
 - (3) JIS standards
 JIS B 9704-1 (Type 4 ESPE), JIS B 9704-2 (Type 4 AOPD)
 - (4) North American standards
 UL61496-1 (Type 4 ESPE), UL61496-2 (Type 4 AOPD), UL508, UL1998,
 CAN/CSA C22.2 No.14, CAN/CSA C22.2 No.0.8
5. Third-Party Certifications
 - (1) TÜV SÜD
 - EC Type-Examination certificate:
 EU Machinery Directive, Type 4 ESPE (EN61496-1), Type 4 AOPD (EN 61496-2)
 - Certificate:
 Type 4 ESPE (EN61496-1), Type 4 AOPD (EN61496-2), EN 61508-1 through -4 (SIL 3),
 EN ISO 13849-1:2015 (PL e, Category 4)
 - (2) UL
 - UL Listing:
 Type 4 and ESPE (UL61496-1), Type 4 AOPD (UL61496-2), UL508, UL1998, CAN/CSA C22.2 No.14,
 CAN/CSA C22.2 No.0.8

6. Other Standards

The F3SG-RR is designed according to the standards listed below. To make sure that the final system complies with the following standards and regulations, you are asked to design and use it in accordance with all other related standards, laws, and regulations. If you have any questions, consult with specialized organizations such as the body responsible for prescribing and/or enforcing machinery safety regulations in the location where the equipment is to be used.

- European Standards: EN415-4, EN691-1, EN692, EN693, IEC/TS 62046
- U.S. Occupational Safety and Health Standards: OSHA 29 CFR 1910.212
- U.S. Occupational Safety and Health Standards: OSHA 29 CFR 1910.217
- American National Standards: ANSI B11.1 to B11.19
- American National Standards: ANSI/RIA R15.06
- Canadian Standards Association CSA Z142, Z432, Z434
- SEMI Standards SEMI S2
- Japan Ministry of Health, Labour and Welfare "Guidelines for Comprehensive Safety Standards of Machinery", Standard Bureau's Notification No. 0731001 dated July 31, 2007.rms and Conditions Agreement

Terms and Conditions Agreement

Warranties.

- (a) Exclusive Warranty. Omron's exclusive warranty is that the Products will be free from defects in materials and workmanship for a period of twelve months from the date of sale by Omron (or such other period expressed in writing by Omron). Omron disclaims all other warranties, express or implied.
- (b) Limitations. OMRON MAKES NO WARRANTY OR REPRESENTATION, EXPRESS OR IMPLIED, ABOUT NON-INFRINGEMENT, MERCHANTABILITY OR FITNESS FOR A PARTICULAR PURPOSE OF THE PRODUCTS. BUYER ACKNOWLEDGES THAT IT ALONE HAS DETERMINED THAT THE PRODUCTS WILL SUITABLY MEET THE REQUIREMENTS OF THEIR INTENDED USE.
- Omron further disclaims all warranties and responsibility of any type for claims or expenses based on infringement by the Products or otherwise of any intellectual property right.
- (c) Buyer Remedy. Omron's sole obligation hereunder shall be, at Omron's election, to (i) replace (in the form originally shipped with Buyer responsible for labor charges for removal or replacement thereof) the non-complying Product, (ii) repair the non-complying Product, or (iii) repay or credit Buyer an amount equal to the purchase price of the non-complying Product; provided that in no event shall Omron be responsible for warranty, repair, indemnity or any other claims or expenses regarding the Products unless Omron's analysis confirms that the Products were properly handled, stored, installed and maintained and not subject to contamination, abuse, misuse or inappropriate modification. Return of any Products by Buyer must be approved in writing by Omron before shipment. Omron Companies shall not be liable for the suitability or unsuitability or the results from the use of Products in combination with any electrical or electronic components, circuits, system assemblies or any other materials or substances or environments. Any advice, recommendations or information given orally or in writing, are not to be construed as an amendment or addition to the above warranty.
- See <http://www.omron.com/global/> or contact your Omron representative for published information.

Limitation on Liability: Etc.

OMRON COMPANIES SHALL NOT BE LIABLE FOR SPECIAL, INDIRECT, INCIDENTAL, OR CONSEQUENTIAL DAMAGES, LOSS OF PROFITS OR PRODUCTION OR COMMERCIAL LOSS IN ANY WAY CONNECTED WITH THE PRODUCTS, WHETHER SUCH CLAIM IS BASED IN CONTRACT, WARRANTY, NEGLIGENCE OR STRICT LIABILITY.

Further, in no event shall liability of Omron Companies exceed the individual price of the Product on which liability is asserted.

Suitability of Use.

Omron Companies shall not be responsible for conformity with any standards, codes or regulations which apply to the combination of the Product in the Buyer's application or use of the Product. At Buyer's request, Omron will provide applicable third party certification documents identifying ratings and limitations of use which apply to the Product. This information by itself is not sufficient for a complete determination of the suitability of the Product in combination with the end product, machine, system, or other application or use. Buyer shall be solely responsible for determining appropriateness of the particular Product with respect to Buyer's application, product or system. Buyer shall take application responsibility in all cases.

NEVER USE THE PRODUCT FOR AN APPLICATION INVOLVING SERIOUS RISK TO LIFE OR PROPERTY WITHOUT ENSURING THAT THE SYSTEM AS A WHOLE HAS BEEN DESIGNED TO ADDRESS THE RISKS, AND THAT THE OMRON PRODUCT(S) IS PROPERLY RATED AND INSTALLED FOR THE INTENDED USE WITHIN THE OVERALL EQUIPMENT OR SYSTEM.

Programmable Products.

Omron Companies shall not be responsible for the user's programming of a programmable Product, or any consequence thereof.

Performance Data.

Data presented in Omron Company websites, catalogs and other materials is provided as a guide for the user in determining suitability and does not constitute a warranty. It may represent the result of Omron's test conditions, and the user must correlate it to actual application requirements. Actual performance is subject to the Omron's Warranty and Limitations of Liability.

Change in Specifications.

Product specifications and accessories may be changed at any time based on improvements and other reasons. It is our practice to change part numbers when published ratings or features are changed, or when significant construction changes are made. However, some specifications of the Product may be changed without any notice. When in doubt, special part numbers may be assigned to fix or establish key specifications for your application. Please consult with your Omron's representative at any time to confirm actual specifications of purchased Product.

Errors and Omissions.



Information presented by Omron Companies has been checked and is believed to be accurate; however, no responsibility is assumed for clerical, typographical or proofreading errors or omissions.

Safety Precautions



Indications and Meanings for Safe Use

The precautions listed in this document indicated by alert symbols and statements must be followed for the safe use of the F3SG-RR. Failure to follow all precautions and alerts may result in an unsafe use or operation. The following word and symbols are used in this document.

Meaning of Signal Word

 DANGER	Indicates an imminently hazardous situation which, if not avoided, is likely to result in serious injury or may result in death. Additionally there may be severe property damage.
 WARNING	Indicates a potentially hazardous situation which, if not avoided, will result in minor or moderate injury, or may result in serious injury or death. Additionally there may be significant property damage.

Meanings of Alert Symbols

	Indicates prohibited actions.
	Indicates mandatory actions.
	Indicates the risk of electric shock.

Alert Statements in this Manual

DANGER

Stop the machine immediately if the F3SG-RR and the machine installed with the F3SG-RR does not operate as intended.



Make sure to test the operation of the F3SG-RR after setting with Rotary Switch and/or End Cap to verify that the F3SG-RR operates as intended. Make sure to stop the machine until the test is complete. Unintended settings may cause a person to go undetected, resulting in serious injury or death.



For users

WARNING

The F3SG-RR must be installed, configured, and incorporated into a machine control system by a sufficiently trained and qualified person. An unqualified person may not be able to perform these operations properly, which may cause a person to go undetected, resulting in serious injury.



For machines

 **WARNING**

Do not use this sensor for machines that cannot be stopped by electrical control. For example, do not use it for a pressing machine that uses full-rotation clutch. Otherwise, the machine may not stop before a person reaches the hazardous part, resulting in serious injury.



To use F3SG-RR in PSDI mode (initiation of cycle operations by a presence sensing device), you must configure an appropriate circuit between F3SG-RR and the machine. For details about PSDI, refer to OSHA1910.217, IEC61496-1, and other relevant standards and regulations.



For installation

 **WARNING**

Make sure Responsible Person tests the operation of the F3SG-RR after installation to verify that the F3SG-RR operates as intended. Make sure to stop the machine until the test is complete. Unintended installation, wiring or function settings may cause a person to go undetected, resulting in serious injury.



Make sure to install the F3SG-RR at the safety distance from the hazardous part of the machine. Otherwise, the machine may not stop before a person reaches the hazardous part, resulting in serious injury.



Install a protective structure so that the hazardous part of a machine can only be reached by passing through the sensor's detection zone. If access to the hazardous part by reaching over the detection zone of a vertically mounted F3SG-RR cannot be excluded, the height of the detection zone and the safety distance shall be determined in consideration of such a risk. Install the sensors so that part of the person is always present in the detection zone when working in a machine's hazardous zones. If a person is able to step into the hazardous zone of a machine and remain behind the F3SG-RR's detection zone, configure the system with restart interlock function. Failure to do so may result in serious injury due to unexpected startup.



Install the reset switch in a location that provides a clear view of the entire hazardous zone and where it cannot be activated from within the hazardous zone.



Install the pre-reset switch always in the hazardous zone and where it cannot be activated from outside the hazardous zone.



The F3SG-RR cannot protect a person from a projectile exiting the hazardous zone. Install protective cover(s) or fence(s).



When the fixed blanking or floating blanking function is used, observe the following. Failure to do so may cause a person to go undetected, resulting in serious injury.



- Responsible Person must verify that a test rod is detected for all detection zones except the blanked area.
- When the fixed blanking function is used, install a protective structure to cover the whole blanked area in order to prevent personnel approach to hazardous part of the machine through the blanked area.

Detection capability gets larger when fixed/floating blanking or reduced resolution function is used. When these functions are used, the safety distance calculation must be based on the increased detection capability for these functions. Otherwise the machine may not stop before a person reaches to the hazardous part, resulting in serious injury.



A warning zone must not be used for safety applications. Always install your system so that a detection zone should be passed before reaching a hazardous part of the machine. If access to the hazardous part by reaching over the detection zone of a vertically mounted F3SG-RR cannot be excluded, the height of the detection zone and the safety distance shall be determined in consideration of such a risk.



When a warning zone is configured, you must attach labels that indicate a border between normal detection zone and warning zone. Otherwise the machine may not stop before a person reaches to the hazardous part, resulting in serious injury.



A warning zone must be configured based on a safety distance.



The muting and override functions disable the safety functions of the device. You must ensure safety using other method when these functions are operating.



Install muting sensors so that they can distinguish between the object that is being allowed to pass through the detection zone and a person. If the muting function is activated by the detection of a person, the machine may not stop operating, resulting in serious injury.



Muting lamps that indicate the state of the muting and override functions must be installed where they are clearly visible to workers from all the operating positions.



Use 2 independent input devices for muting inputs. Failure to do so may result in a muting status due to a single muting sensor's failure.



Muting related time must be properly configured for its application by a sufficiently trained and qualified person, and the person must have responsibility for settings, especially when setting the muting time limit to infinite.



Install F3SG-RR, muting sensor, and physical barrier, and configure time settings for muting so that an operator should not enter hazardous zone.



The dynamic muting function can configure a new muting zone after muting is enabled based on a result measuring a workpiece height for a certain period of time. The function must be completely verified by a trained and qualified person before being used. Take additional safety measures if necessary.



Install the switch to activate the override function in a location that provides a clear view of the entire hazardous zone and where it cannot be activated from within the hazardous zone. Make sure that nobody is in the hazardous zone before activating the override function.



Override time must be properly configured for its application by a sufficiently trained and qualified person.



Make sure to connect an override cancel switch to the Reset line when using the override function. Otherwise the override state may not be released by the override cancel switch, resulting in serious injury.



When muting error occurs with workpiece blocking the F3SG-RR, there are two methods to forcibly remove the workpiece.

- 1) Manual operation (with additional safety measure); or
- 2) Override function (Override at Normal Operation / Override upon Startup)

Only one of the methods, either 1) or 2) must be used.

If they are used at the same time, the override may be activated at an unexpected timing.



Install F3SG-RR so that it is not affected by reflective surfaces. Failure to do so may hinder detection, resulting in serious injury. For an installation distance from reflective surfaces, see 4-1-3. *Distance from Reflective Surfaces*.



When using more than 1 set of F3SG-RR in adjacent areas, the emitter of one F3SG-RR may interfere with the receiver of the other, causing the safety functions to stop working properly. Install, configure and maintain them so that mutual interference does not occur.



Make sure that foreign material such as water, oil, or dust does not enter the F3SG-RR or the connector while the cap is removed.



To change the response time, calculate the safety distance based on the setting. Otherwise, the machine may not stop before a person reaches the hazardous part, resulting in serious injury.



Do not use the sensor system with mirrors in a retro-reflective configuration as shown below. Doing so may hinder detection. It is possible to use mirrors to alter the detection zone to a 90-degree angle.

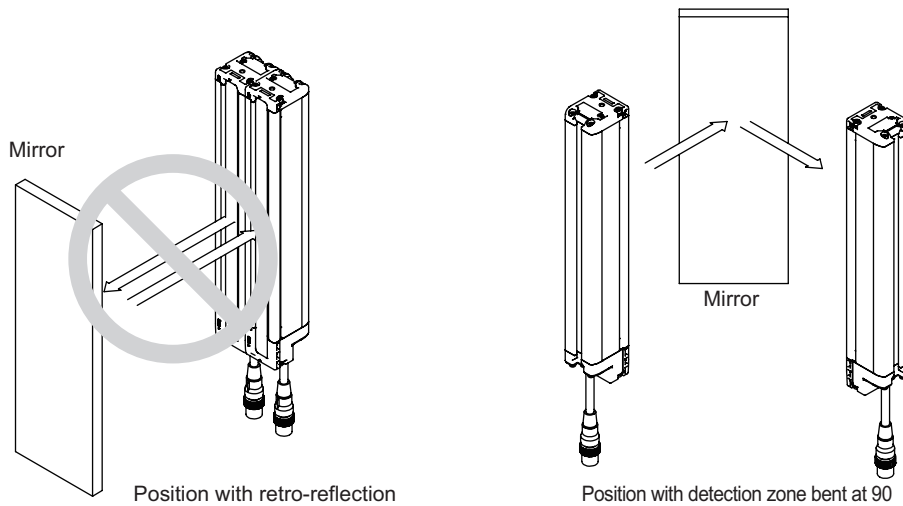

Perform an inspection for all F3SG-RR as described in *Chapter 6 Checklists*. When using cascade connections, perform inspections for every connected F3SG-RR.



For wiring

 **WARNING**

When using the PNP output, connect the load between the output and 0 V line. When using the NPN output, connect the load between the output and +24 VDC line. Connecting the load between the output and a different power supply line from the above will result in a dangerous condition because the operation mode of safety output is reversed to "Dark-ON".



When using the PNP output, do not ground +24 VDC line. When using the NPN output, do not ground 0 V line. Otherwise, a ground fault may turn the safety output ON, resulting in a failure of stopping the machine.



Configure the system by using the optimal number of safety outputs that satisfy the requirements of the necessary safety category.



Do not connect each line of F3SG-RR to a DC power supply of higher than 24 VDC+20%. Also, do not connect it to an AC power supply. Failure to do so may result in electric shock.



Make sure to perform wiring while the power supply is OFF.



Do not use the auxiliary output for safety applications. Failure to do so may result in serious injury when the F3SG-RR fails.



For the F3SG-RR to comply with IEC 61496-1 and UL 508, the DC power supply unit must satisfy all of the following conditions:



- Must be within the rated power voltage (24 VDC \pm 20%)
- Must have tolerance against the total rated current of devices if it is connected to multiple devices
- Must comply with EMC directives (industrial environment)
- Double or reinforced insulation must be applied between the primary and secondary circuits
- Automatic recovery of overcurrent protection characteristics
- Output holding time must be 20ms or longer
- Must satisfy output characteristic requirements for class 2 circuit or limited voltage current circuit defined by UL508. Refer to 4-5-2. *Power Supply Unit*.
- Must comply with laws and regulations, regarding EMC and electrical equipment safety, of the country or region where the F3SG-RR is used (For example, in EU, the power supply must comply with the EMC Directive and the Low Voltage Directive.)

Double or reinforced insulation from hazardous voltage must be applied to all input and output lines. Failure to do so may result in electric shock.



Extension of the cable must be within a specified length. If it isn't, safety function may not work properly, resulting in danger.



Settings

 **WARNING**

Some settings of functions or the setting recovery function configurable with the configuration software, SD Manager 2 (hereinafter referred to as "Configuration Tool") may increase risks. Make sure the Responsible Person conduct a thorough risk assessment analysis before managing and changing the settings. Unintended changes to the settings may cause a person go to undetected, resulting in serious injury.



Other

 **WARNING**

Do not try to disassemble, repair, or modify this product. Doing so may cause the safety functions to stop working properly.



Do not use the F3SG-RR in environments where flammable or explosive gases are present. Doing so may result in explosion.



Perform daily and 6-month inspections for the F3SG-RR as described in *Chapter 6 Checklists*. Otherwise, the system may fail to work properly, resulting in serious injury.



Do not use the F3SG-RR in environments where strong electromagnetic field may be produced. Doing so may cause the safety functions to stop working properly.



Precautions for Safe Use

Make sure to observe the following precautions that are necessary for ensuring safe use of the product.

Do not install, use, or store the F3SG-RR in the following types of environments:

- Areas exposed to intense interference light, such as direct sunlight
 - Areas with high humidity where condensation is likely to occur
 - Areas where corrosive gases are present
 - Areas exposed to vibration or shock levels higher than in the specification provisions
 - Areas where the pollution degree is harsher than 3, such as outdoor environment
 - Areas where the product may get wet with oil that can solve adhesive
 - Areas where foreign material such as spatter adheres to the F3SG-RR
- Loads must satisfy both of the following conditions:
 - Not short-circuited
 - Not used with a current that is higher than the rating
 - Do not drop the product.
 - Dispose of the product in accordance with the relevant rules and regulations of the country or area where the product is used.
 - Make sure that the F3SG-RR is securely mounted and its cables and connectors are properly secured with the torque recommended in this document.
 - Do not apply excessive force (0.2 N·m or more) to the Rotary Switch when operating it. Doing so may damage and make the Rotary Switch inoperable. Do not operate the Rotary Switch with tools that may damage the product.
 - Bending radii of cables must be equal to or higher than specified minimum values.
 - When replacing the cable connectors with other types of connectors, use connectors that provide a protection grade of IP54 or higher.
 - Be sure to route the input/output lines for the F3SG-RR separate from high-potential power lines or through an exclusive conduit.
 - To extend a cable length with a cable other than the dedicated cable, use a cable with the same or superior specifications.
-  Refer to 4-5-3-6. *Extending Cable Length with Commercially Available Cable*
- Use the F39-JD□RA cables in environment where the product may be exposed to oil. Using the other cables in such an environment may cause cutting oils or other substances to enter the cables, resulting in a risk of damaging or burning the product.
 - Interface Unit F39-GIF-1 is dedicated to the F3SG-RR and F3SG-RA-02TS series. Do not use it for F3SJ-A, F3SJ-E/B or F3SG-RA series.
 - When powering on the F3SG-RR with the Interface Unit being connected to the F3SG-RR, the PC COM lines (or MUTE A and B lines) must be open. Otherwise the F3SG-RR goes to the Lockout state or does not send the safety outputs (OSSDs).
 - Read and understand this document for setting with the Rotary Switch and End Cap.
 - The rated life of the LEDs used for this product is 6 years.
 - Some cutting oils may affect the product. Before using cutting oils, make sure that the oils should not cause deterioration or degradation of the product.
 - Do not use the product with degraded protective structure such as swelling and crack in housing and/or sealing components. Otherwise cutting oil or other substance may enter the product, resulting in a risk of corruption or burning.

Precautions for Correct Use

Observe the precautions described below to prevent operation failure, malfunctions, or undesirable effects on product performance.

■ Storage conditions and installation environment

- Do not install, use, or store the F3SG-RR in the following types of environments:
 - For a long time at a temperature or humidity out of the specified range
 - Areas submerged in water or subject to rain water
- This is a class A product. In residential areas it may cause radio interference, in which case the Responsible Person may be required to take adequate measures to reduce interference.

■ Wiring and installation

- Properly perform the wiring after confirming the signal names of all the terminals.
- Be sure that there is nothing in the detection zone and the stable-state indicator is turned ON after power is turned ON.
- Do not operate the control system until 2 seconds or more after turning ON the power of the F3SG-RR.
- When using a commercially available switching regulator power supply, make sure to ground the PE terminal (protective earth terminal).
- Install the emitter and receiver to the same vertical direction.
- Use brackets of specified quantities and locations according to the dimensions.
If the brackets described above are not used, ratings and performance cannot be met.
- Do not install the F3SG-RR close to a device that generates high-frequency noise. Otherwise, take sufficient blocking measures.
- Sharing the power supply with other devices may cause the F3SG-RR to be affected by noise or voltage drop. It is recommended that the F3SG-RR use a power supply dedicated for safety components, not shared with other devices.

■ Cleaning

- Do not use thinner, benzene, or acetone for cleaning. They affect the product's resin parts and paint on the housing.
- Use a soft cloth which is dry or wetted with clean water for cleaning. Do not use solvents.

■ Object detection

- The F3SG-RR cannot detect transparent and/or translucent objects.

■ Settings

- Do not operate the Rotary Switch during normal operation of the F3SG-RR. Otherwise, the F3SG-RR enters the Lockout state.
- Be sure that the F3SG-RR is in the Setting mode when making a change to the setting.

■ Oil resistance

The F3SG-RR passed the testing for the resistance to the oils listed in the table below. Refer to the table for selection of lubricant or cutting oils to be used.

Test Oil Type	JIS Type	Product Name	Manufacturer	
Water-soluble cutting oils	A1	Yushiroken EC50T3	Yushiro Chemical Industry Co., Ltd.	
		Yushiroken FGE366		
		Yushiroken FX90		
		Yushiroken FGE180		
		Yushiroken EC980		
	A2	Yushiroken FGM427		
		Yushiroken FGS700		Kyodo Yushi Co., Ltd.
		Yushiroken GTS-100		
		Yushiroken Synthetic #770TG		
		Multicool CSF-9000		
		Multicut SGV		
A3	Yushiroken FGC950PR	Yushiro Chemical Industry Co., Ltd.		
	Yushiroken SC46TY			
Non-water-soluble cutting oils	N1	Yushiron Oil CG5	Yushiro Chemical Industry Co., Ltd.	
	N3	Yushiron Cut ABAS BZ224K		
	N4	Yushiron Cut ABAS KZ440		

Note 1. The product passed the 240-hour immersion test at 55°C to the listed oils, maintaining the insulation resistance of 20 MΩ and preventing the ingress of the oils.

Note 2. When using the other oils than listed, make sure that the oils should not cause deterioration or degradation of the product.

Visual Aids

The following symbols appear in this document to help you locate different types of information.



CHECK!

Indicates important information or advice on a function or operation of the product.



Indicates page numbers or chapter title of related information.

Table of Contents

Legislation and Standards	i
Terms and Conditions Agreement	iii
Safety Precautions	v
Precautions for Safe Use	xi
Precautions for Correct Use	xii
Visual Aids	xiv
Chapter1 Overview and Specifications	1
1-1. What is Included	2
1-2. System Components	3
1-2-1. Basic Components	4
1-3. List of Features	5
1-3-1. Model Overview	5
1-3-2. List of Features	5
1-4. LED Indicators	6
1-4-1. LED Indicator Status	7
1-5. Ratings/Specifications	8
1-6. List of Models	11
1-6-1. List of Models/Response Time/Current Consumption/Weight	11
1-6-2. Calculation of Response Time of Cascaded Segments	13
Chapter2 System Operation and Functions	15
2-1. Combination of Functions	16
2-2. Operating States	18
2-2-1. Machine Run State	18
2-2-2. Machine Stop State	18
2-2-3. Interlock State	18
2-2-4. Lockout State	18
2-2-5. Setting State	18
2-3. Optical Synchronization	19
2-3-1. Overview	19
2-4. Scan Code Selection	20
2-4-1. Overview	20
2-4-2. Factory Default Setting	20
2-4-3. Setting	20
2-4-4. Setting with Configuration Tool	20
2-5. PNP/NPN Selection	21
2-5-1. Overview	21
2-5-2. Factory Default Setting	21

2-5-3. Setting with Configuration Tool	21
2-6. Self-Test	22
2-6-1. Overview	22
2-6-1-1. Self-Test details	22
2-6-1-2. Waveform of safety outputs	23
2-7. External Test	24
2-7-1. Overview	24
2-7-2. Factory Default Setting	24
2-7-3. Setting	25
2-7-4. Setting with Configuration Tool	25
2-8. Lockout Reset	26
2-8-1. Overview	26
2-9. Interlock	27
2-9-1. Overview	27
2-9-2. Factory Default Setting	30
2-9-3. Setting with Configuration Tool	31
2-10. External Device Monitoring (EDM)	32
2-10-1. Overview	32
2-10-2. Factory Default Setting	33
2-10-3. Setting with Configuration Tool	33
2-11. Auxiliary Output	35
2-11-1. Overview	35
2-11-2. Factory Default Setting	35
2-11-3. Setting with Configuration Tool	36
2-12. Muting	38
2-12-1. Overview	38
2-12-2. Standard Muting Mode	40
2-12-3. Exit-Only Muting Mode	50
2-12-4. Position Detection Muting Mode	56
2-12-5. Dynamic Muting	60
2-12-6. Factory Default Setting	61
2-12-7. Setting with Configuration Tool	61
2-13. Override	63
2-13-1. Overview	63
2-13-2. Override at Normal Operation	64
2-13-3. Override upon Startup	68
2-13-4. Setting with Configuration Tool	69
2-14. Fixed Blanking	70
2-14-1. Overview	70
2-14-2. Factory Default Setting	73
2-14-3. Setting with Configuration Tool	73
2-15. Floating Blanking	74

2-15-1.Overview	74
2-15-2.Factory Default Setting	77
2-15-3.Setting with Configuration Tool	78
2-16. Reduced Resolution	79
2-16-1.Overview	79
2-16-2.Factory Default Setting	80
2-16-3.Setting with Configuration Tool	81
2-17. Warning Zone	82
2-17-1.Overview	82
2-17-2.Factory Default Setting	85
2-17-3.Setting with Configuration Tool	85
2-18. Setting Zone Adjacency Conditions	86
2-19. Response Time Adjustment	88
2-19-1.Overview	88
2-19-2.Factory Default Setting	88
2-19-3.Setting with Configuration Tool	88
2-20. Lamp	89
2-20-1.Overview	89
2-20-2.Factory Default Setting	89
2-20-3.Setting with Configuration Tool	89
2-21. Designated Beam Output	92
2-21-1.Overview	92
2-21-2.Factory Default Setting	92
2-21-3.Setting with Configuration Tool	92
2-22. Light Level Monitoring	94
2-22-1.Incident Light Level Information	94
2-22-1-1. Overview	94
2-22-1-2. Setting with Configuration Tool	94
2-22-2.Ambient Light Level Information	94
2-22-2-1. Overview	94
2-22-2-2. Setting with Configuration Tool	94
2-23. Maintenance Information	95
2-23-1.Overview	95
2-23-2.Error Log	95
2-23-3.Warning Log	95
2-23-4.Power-ON Time	95
2-23-5.Load Switching Frequency	96
2-23-6.Muting Statistics Information	96
2-24. Operating Status Monitoring	97
2-24-1.Overview	97
2-24-2.Readout Information	97
2-25. Setting Recovery	98

2-25-1. Overview	98
<hr/>	
Chapter3 Setting with Rotary Switch and End Cap	99
<hr/>	
3-1. List of Features Configurable by Rotary Switch	100
3-2. Rotary Switch	101
3-3. List of Features Configurable by End Cap	102
3-4. End Cap	103
<hr/>	
Chapter4 Wiring/Installation	105
<hr/>	
4-1. Installation Considerations	107
4-1-1. Detection Zone and Approach	107
4-1-2. Safety Distance	108
4-1-2-1. Safety Distance Formulas according to ISO 13855/EN ISO 13855	108
4-1-2-2. Safety Distance Formulas according to ANSI B11.19	112
4-1-3. Distance from Reflective Surfaces	113
4-1-3-1. F3SG-4RR (Type 4 ESPE)	113
4-1-4. Mutual Interference Prevention	114
4-2. Cascade Connection	116
4-2-1. Overview	116
4-2-2. Connection Procedure	118
4-3. Dimensions	119
4-3-1. Mounted with Free-Location Brackets (F39-LGRA)	119
4-3-1-1. Backside Mounting	119
4-3-1-2. Side Mounting	120
4-3-1-3. Free-Location Bracket / Intermediate Bracket (F39-LGRA)	121
4-3-2. Mounted with Top/Bottom Brackets (F39-LGRTB) and Intermediate Bracket (F39-LGRA)	122
4-3-2-1. Backside Mounting	122
4-3-2-2. Side Mounting	123
4-3-2-3. Top/Bottom Bracket (F39-LGRTB)	124
4-3-3. Mounted with Top/Bottom Brackets (F39-LGRTB-2) and Intermediate Bracket (F39-LGRA)	125
4-3-3-1. Backside Mounting	125
4-3-3-2. Side Mounting	126
4-3-3-3. Top/Bottom Bracket (F39-LGRTB-2)	127
4-3-4. Mounted with Top/Bottom Brackets (F39-LGRTB-3) and Intermediate Bracket (F39-LGRA)	128
4-3-4-1. Backside Mounting	128
4-3-4-2. Side Mounting	129
4-3-4-3. Top/Bottom Bracket (F39-LGRTB-3)	130
4-3-5. Mounted with Top/Bottom Brackets (F39-LGRTB-□) and Accessories	131
4-3-5-1. Connected with Cascading Cable (F39-JGR2WTS)	131

4-3-5-2. Connected with Bluetooth® Communication Unit (F39-BT)	132
4-3-5-3. Connected with Lamp (F39-LP) or Lamp and Bluetooth® Communication Unit (F39-BTLP)	133
4-4. Mounting	134
4-4-1. Mounting Method	134
4-4-2. Number of Brackets Required	134
4-4-3. Mounting Procedure	135
4-4-3-1. Mounting with Free-Location Brackets (F39-LGRA)	135
4-4-3-2. Mounting with Top/Bottom Bracket (F39-LGRTB-□) and Intermediate Bracket (F39-LGRA)	138
4-4-4. Beam Alignment Procedure	143
4-5. Wiring	144
4-5-1. Wiring Precautions	144
4-5-2. Power Supply Unit	145
4-5-3. Cable Connections	146
4-5-3-1. Single-Ended Cable (Oil-Resistant Cable)	146
4-5-3-2. Single-Ended Cable	147
4-5-3-3. Double-Ended Cable	148
4-5-3-4. Cascading Cable	150
4-5-3-5. Reduced Wiring Connector System	151
4-5-3-6. Extending Cable Length with Commercially Available Cable	152
4-5-4. Functional Earth Connection	153
Chapter5 Input/Output Circuit and Applications	155
5-1. Input/Output Circuit	157
5-1-1. Entire Circuit Diagram	157
5-1-2. Input Circuit Diagram by Function	159
5-2. Wiring Examples	160
5-2-1. Standalone F3SG-RR using PNP Outputs	160
5-2-1-1. Auto Reset Mode, EDM enabled and PNP Outputs	160
5-2-1-2. Manual Reset Mode, EDM disabled and PNP Outputs	161
5-2-1-3. Replacing the F3SJ-B Safety Light Curtain with F3SG-RR	162
5-2-1-4. F3SG-RR with Reduced Wiring Connector and PNP Outputs	163
5-2-1-5. Pre-Reset Mode using PNP Output	164
5-2-2. Muting using PNP Outputs	165
5-2-2-1. Standard Muting Mode/Exit-Only Muting Mode using PNP Outputs	165
5-2-2-2. Standard Muting Mode/Exit-Only Muting Mode with Reduced Wiring Connector and PNP outputs	166
5-2-2-3. Standard Muting Mode/Exit-Only Muting Mode with two Muting Sensors using PNP Outputs	167
5-2-2-4. Standard Muting Mode with four Muting Sensors using PNP Outputs	168
5-2-3. Standalone F3SG-RR using NPN Outputs	169

5-2-3-1. Auto Reset Mode, EDM enabled and NPN Outputs	169
5-2-3-2. Manual Reset Mode, EDM disabled and NPN Outputs	170
5-2-3-3. Replacing the F3SJ-B Safety Light Curtain with F3SG-RR	171
5-2-3-4. F3SG-RR with Reduced Wiring Connector and NPN Outputs	172
5-2-3-5. Pre-Reset Mode using NPN Output	173
5-2-4. Muting using NPN Outputs	174
5-2-4-1. Standard Muting Mode/Exit-Only Muting Mode using NPN Outputs	174
5-2-4-2. Standard Muting Mode/Exit-Only Muting Mode with two Muting Sensors using NPN Outputs	175
5-2-4-3. Standard Muting Mode with four Muting Sensors using NPN Outputs	176
5-3. Connectable Safety Control Units	177
Chapter6 Checklists	179
6-1. Pre-Operation Checklists	180
6-1-1. Checklists	180
6-1-1-1. Installation Condition Check	180
6-1-1-2. Wiring Check Before Power Is Turned ON	180
6-1-1-3. Operation Check While the Machine Is Stopped	181
6-1-1-4. Checking that Hazardous Parts Stop While the Machine Operates	182
6-2. Maintenance Checklists	183
6-2-1. Checklists	183
6-2-1-1. Inspection at Startup and When Changing Operators	183
6-2-1-2. Checking that Hazardous Parts Stop While the Machine Operates	184
6-2-1-3. Items to Inspect Every 6 Months or When Machine Settings Are Changed	184
Chapter7 Appendix	187
7-1. Troubleshooting	188
7-1-1. Lockout State	189
7-1-1-1. Description	189
7-1-1-2. Troubleshooting	190
7-1-2. Warning	193
7-1-2-1. Description	193
7-1-2-2. Troubleshooting	193
7-1-2-3. Muting Sequence Error Indication	194
7-1-2-4. Interlock Sequence Error Indication	195
7-1-3. Troubles Other Than in Lockout State	195
7-2. Optional Accessories(Sold Separately)	196
7-3. Glossary	202
7-4. Revision History	206

Chapter 1 Overview and Specifications

1-1. What is Included	2
1-2. System Components	3
1-2-1. Basic Components	4
1-3. List of Features	5
1-3-1. Model Overview	5
1-3-2. List of Features	5
1-4. LED Indicators	6
1-4-1. LED Indicator Status	7
1-5. Ratings/Specifications	8
1-6. List of Models	11
1-6-1. List of Models/Response Time/Current Consumption/Weight	11
1-6-2. Calculation of Response Time of Cascaded Segments	13

1-1. What is Included

Before use, confirm that the items below are included with the product.

If you find that an item is missing, please contact your local branch office or distributor.

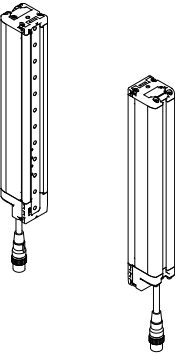
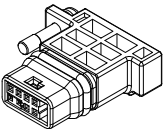
Product	Quantity
<p>F3SG-RR□□□□□□□□ main unit</p> 	<p>Emitter x 1, Receiver x 1</p>
<p>Warning Zone Label</p>	<p>1</p>
<p>Troubleshooting Guide Sticker</p>	<p>1</p>
<p>Safety Precautions</p>	<p>3</p>
<p>Quick Installation Manual</p>	<p>1</p>
<p>End Cap (for External Test Input Selection) (Color: White)</p> 	<p>1</p>

1-2. System Components

This section describes the system components and part names of the F3SG-RR system.

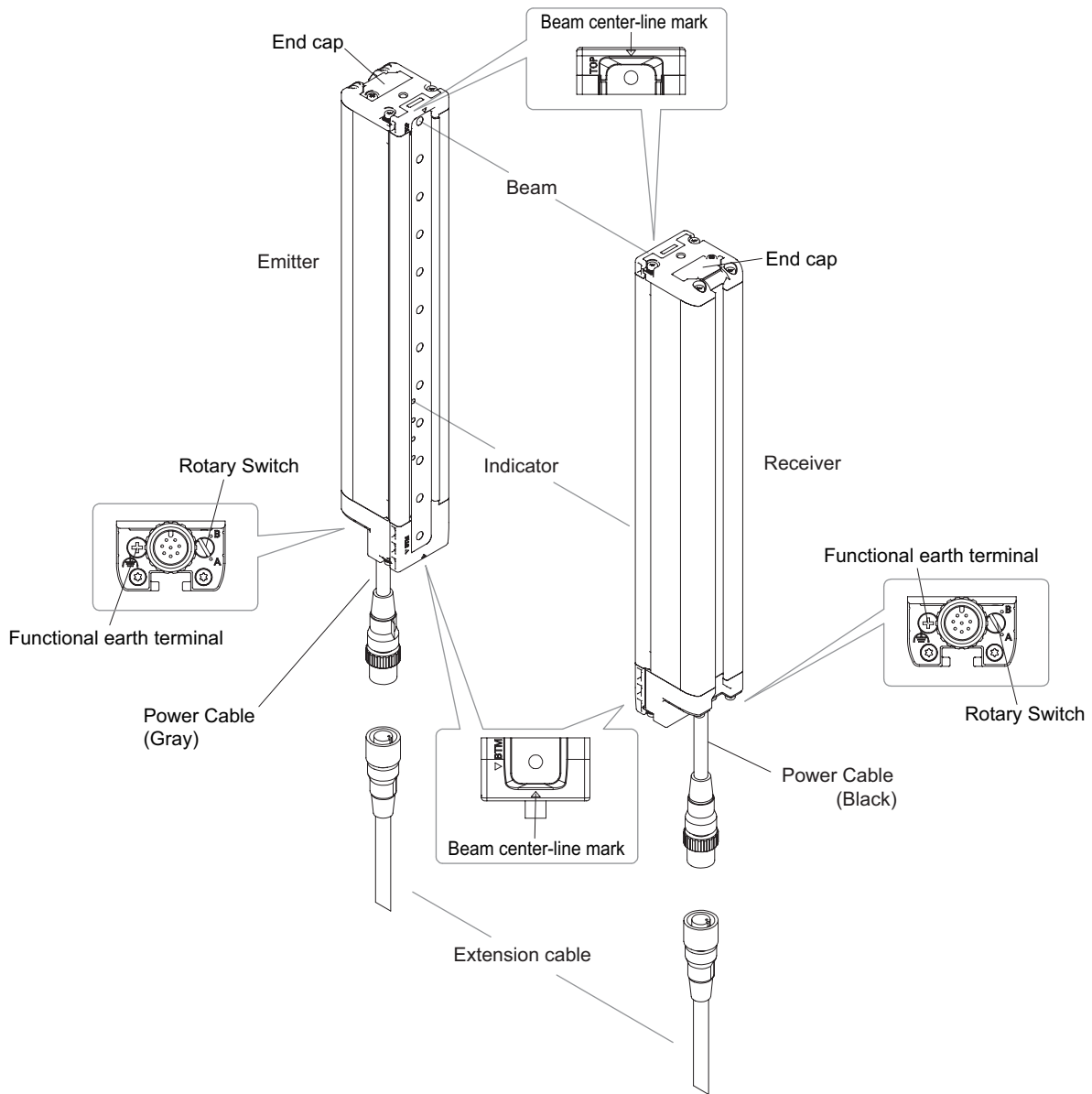

1-2-1. Basic Components

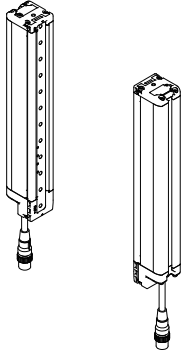
Component	Model name	Description
<p data-bbox="156 315 316 338">Emitter, receiver</p> 	<p data-bbox="576 315 842 338">F3SG-□RR□□□□-□□-□</p>	<p data-bbox="868 315 1385 371">Select a model name based on the required protective height.</p> <p data-bbox="868 371 1321 394">The model name can be understood as follows:</p> <div style="text-align: center;"> <p data-bbox="1015 416 1278 439">F3SG-□RR□□□□-□□-□</p> <div style="display: flex; justify-content: center; gap: 20px;"> <div style="text-align: center;"> <p data-bbox="1082 450 1090 472"> </p> <p data-bbox="1082 472 1090 488">1</p> </div> <div style="text-align: center;"> <p data-bbox="1123 450 1155 472">└───┘</p> <p data-bbox="1155 472 1171 488">2</p> </div> <div style="text-align: center;"> <p data-bbox="1203 450 1235 472">└──┘</p> <p data-bbox="1235 472 1251 488">3</p> </div> <div style="text-align: center;"> <p data-bbox="1267 450 1283 472"> </p> <p data-bbox="1267 472 1283 488">4</p> </div> </div> </div> <ul style="list-style-type: none"> <li data-bbox="868 517 1107 539">1: ESPE type (4: Type 4) <li data-bbox="868 546 1107 568">2: Protective height (mm) <li data-bbox="868 575 1107 598">3: Object resolution (mm) <li data-bbox="868 604 1378 627">4: L: Emitter, D: Receiver, blank: Emitter and receiver.



To distinguish between the emitter and receiver, find the labels attached to the front of the F3SG-RR. The label on the emitter reads "EMITTER" and the label on the receiver reads "RECEIVER".

CHECK!

1-3. List of Features

1-3-1. Model Overview

The F3SG-RR series is an advance model, allowing you to configure the safety light curtain to fit your application.

Refer to the List of Features below for available features.

1-3-2. List of Features

The F3SG-RR safety light curtain family has the following features. For the F3SG-RR, some of the features are available or configurable by the Rotary Switch or End Cap on the body of the safety light curtain or the Configuration Tool (SD Manager 2) via a PC.

Feature	Setting	Factory default setting	Page
Optical Synchronization	--	--	p.19
Scan Code Selection	with Rotary Switch	Code A	p.20
PNP/NPN Selection	with Configuration Tool	PNP	p.21
Self-Test	--	--	p.22
External Test	with End Cap	24 V Active	p.24
Lockout Reset	--	--	p.26
Interlock	with Configuration Tool	Auto Reset Mode	p.27
External Device Monitoring (EDM)	with Configuration Tool	Enable	p.32
Auxiliary Output	with Configuration Tool	Safety output information (Inverted signal output: Enable)	p.35
Muting	with Configuration Tool	Disable	p.38
Override	with Configuration Tool	Disable	p.63
Fixed Blanking	with Configuration Tool	Disable	p.70
Floating Blanking	with Configuration Tool	Disable	p.74
Reduced Resolution	with Configuration Tool	Disable	p.79
Warning Zone	Configuration Tool	Disable	p.82
Response Time Adjustment	Configuration Tool	Normal mode	p.88
Lamp	Configuration Tool	Red: Safety output information (Inverted signal output: Enable) Orange: Stable-state information (Inverted signal output: Enable, Output pattern: ON 1 time) Green: Safety output information	p.89
Designated Beam Output	with Configuration Tool	Disable	p.92
Light Level Monitoring	Only reading data from sensor available	--	p.94
Error Log/Warning Log	Only reading data from sensor available	--	p.95
Power-ON Time Threshold	with Configuration Tool	30,000 h	p.95
Load Switching Frequency	Configuration Tool	100,000 times in 1-time increments	p.96
Operating Status Monitoring	Only reading data from sensor available	--	p.97
Setting Recovery	with Configuration Tool	--	p.98

1-4. LED Indicators

- 1. Test indicator (Green)
- 2. Operating range indicator (Green)
- 3. Power indicator (Green)
- 4. Lockout indicator (Red)

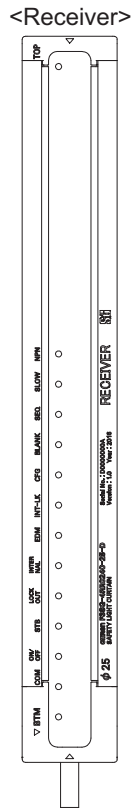
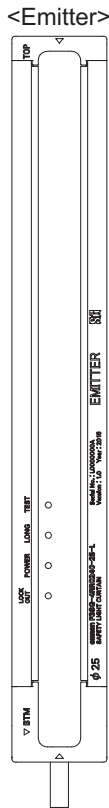

- 1. Top-beam-state indicator (Blue)
- 2. PNP/NPN mode indicator (Green)
- 3. Response time indicator (Green)
- 4. Sequence error indicator (Yellow)
- 5. Blanking indicator (Green)
- 6. Configuration indicator (Green)
- 7. Interlock indicator (Yellow)
- 8. External device monitoring indicator (Green)
- 9. Internal error indicator (Red)
- 10. Lockout indicator (Red)
- 11. Stable-state indicator (Green)
- 12. ON/OFF indicator (Green/Red)
- 13. Communication indicator (Green)
- 14. Bottom-beam-state indicator (Blue)

1-4-1. LED Indicator Status

Shown below are the of factory default indication statuses of F3SG-RR LED indicators.

Emitter

Location	Name of Indicator		Color	Illuminated	Blinking
1	Test	TEST	Green	-	External Test is being performed
2	Operating range	LONG	Green	Always illuminated	Lockout state due to Scan code setting error
3	Power	POWER	Green	Power is ON.	Error due to noise
4	Lockout	LOCKOUT	Red	-	Lockout state due to error in emitter

Receiver

Location	Name of Indicator		Color	Illuminated	Blinking
1	Top-beam-state	TOP	Blue	The top beam is unblocked	Muting/Override state, or Lockout state due to Cap error or Other sensor error
2	PNP/NPN mode	NPN	Green	NPN mode is selected	-
3	Response time	SLOW	Green	Response Time Adjustment is enabled	-
4	Sequence error	SEQ	Yellow	-	Sequence error in Muting or Pre-reset mode
5	Blanking	BLANK	Green	Blanking, Warning Zone or Reduced Resolution is enabled	Blanking Monitoring error
6	Configuration	CFG	Green	-	Zone measurement being performed by Dynamic Muting, or Lockout state due to Parameter error or Cascading Configuration error
7	Interlock	INT-LK	Yellow	Interlock state	Pre-reset mode *2
8	External device monitoring	EDM	Green	RESET input is in ON state *1	Lockout state due to EDM error
9	Internal error	INTERNAL	Red	-	Lockout state due to Internal error, or error due to abnormal power supply or noise
10	Lockout	LOCKOUT	Red	-	Lockout state due to error in receiver
11	Stable-state	STB	Green	Incident light level is 170% or higher of ON-threshold	Safety output is instantaneously turned OFF due to ambient light or vibration
12	ON/OFF	ON/OFF	Green	Safety output is in ON state	-
			Red	Safety output is in OFF state	Lockout state due to Safety Output error, or error due to abnormal power supply or noise
13	Communication	COM	Green	Synchronization between emitter and receiver is maintained	Lockout state due to Communication error, or error due to abnormal power supply or noise
14	Bottom-beam-state	BTM	Blue	The bottom beam is unblocked	Muting/Override state, or Lockout state due to Scan code setting error

*1. The EDM indicator is illuminated when the EDM input is in the ON state regardless of the use of the EDM function.

*2. Refer to the timing chart of Pre-Reset mode in 2-9. *Interlock* for more information of blinking patterns.



Refer to 7-3. *Glossary* for definitions of terms used in the table above.







CHECK!





TOP, CFG, LOCKOUT, STB and ON/OFF indicators on the receiver of the F3SG-RR blink when the F3SG-RR is in Setting mode. The blinking patterns are Blinking Once or Blinking Twice, depending on the access level. Refer to *Safety Light Curtain Configuration Tool for Model F3SG (SD Manager 2) User's Manual* for more information on the statuses of the LED indicators in the Setting mode.

1-5. Ratings/Specifications

The □□□□ in the model names indicate the protective heights in millimeters.

		F3SG-4RR□□□□-14	F3SG-4RR□□□□-25
Performance			
Object Resolution (Detection Capability)	Opaque objects		
	14-mm dia.		25-mm dia.
Beam Gap	10 mm		20 mm
Number of Beams	23 to 191		12 to 96
Lens Size	5.2 × 3.4 (W × H) mm		6.0 × 5.0 (W × H) mm
Protective Height	240 to 1920 mm		240 to 1920 mm
Operating Range	0.3 to 10.0 m		0.3 to 17.0 m
Response Time	ON to OFF	Normal mode: 8 to 18 ms *1 Slow mode: 16 to 36 ms *1 *2	
	OFF to ON	Normal mode: 40 to 90ms (synchronized), 140 to 190ms (not synchronized) *1	
	*1. Response time when used in one segment system or in cascaded connection.  1-6. List of Models for more information. *2. Selectable by Configuration Tool.		
Effective Aperture Angle (EAA) (IEC 61496-2)	±2.5° max., emitter and receiver at operating range of 3 m or greater		
Light Source	Infrared LEDs, Wavelength: 870 nm		
Startup Waiting Time	2 s max.		
Electrical			
Power Supply Voltage (Vs)	SELV/PELV 24 VDC±20% (ripple p-p 10% max.)		
Current Consumption	 1-6. List of Models		
Safety Outputs (OSSD)	Two PNP or NPN transistor outputs (PNP or NPN is selectable by Configuration Tool.)		
	Load current of 300 mA max., Residual voltage of 2 V max. (except for voltage drop due to cable extension), Capacitive load of 1 μF max., Inductive load of 2.2 H max. *1 Leakage current of 1 mA max. (PNP), 2 mA max. (NPN) *2 *1. The load inductance is the maximum value when the safety output frequently repeats ON and OFF. When you use the safety output at 4 Hz or less, the usable load inductance becomes larger. *2. These values must be taken into consideration when connecting elements including a capacitive load such as a capacitor.		
Auxiliary Output	One PNP or NPN transistor output (PNP or NPN is selectable by Configuration Tool.)		
	Load current of 100 mA max., Residual voltage of 2 V max .		
Output Operation Mode	Safety Output	Light-ON (Safety output is enabled when the receiver receives an emitting signal.)	
	Auxiliary Output	Safety output (Inverted signal output:Enable) (default) (Cofigurable by Configuration Tool)	
Input Voltage	External device monitoring input (Lockout reset input)	PNP ON voltage: Vs-3 V to Vs (short circuit current: approx. 6.5 mA) * OFF voltage: 0 V to 1/2 Vs, or open (short circuit current: approx. 8.0 mA) * NPN ON voltage: 0 V to 3 V (short circuit current: approx. 8.0 mA) OFF voltage: 1/2 Vs to Vs, or open (short circuit current: approx. 6.5 mA) *	
	Muting input A/B	PNP ON voltage: Vs-3 V to Vs (short circuit current: approx. 3.0 mA) * OFF voltage: 0 V to 1/2 Vs, or open (short circuit current: approx. 5.0 mA) * NPN ON voltage: 0 V to 3 V (short circuit current: approx. 5.0 mA) OFF voltage: 1/2 Vs to Vs, or open (short circuit current: approx. 3.0 mA) *	
	Test input	24 V Active setting: ON voltage: 9 V to Vs (short circuit current: approx. 2.5 mA) * OFF voltage: 0 V to 3 V or open (short circuit current: approx. 2.0 mA) 0 V Active setting: ON voltage: 0 V to 3 V (short circuit current: approx. 2.0 mA) OFF voltage: 9 V to Vs or open (short circuit current: approx. 2.5 mA) *	
* The Vs indicates a supply voltage value in your environment.			

		F3SG-4RR□□□□-14	F3SG-4RR□□□□-25
Overvoltage Category (IEC 60664-1)	II		
Indicators	 1-4-1. LED Indicator Status		
Protective Circuit	Output short protection, Power supply reverse polarity protection		
Insulation Resistance	20 MΩ or higher (500 VDC megger)		
Dielectric Strength	1,000 VAC, 50/60 Hz (1 min)		
Functional			
Mutual Interference Prevention (Scan Code)	This function prevents mutual interference in up to two F3SG-RR systems.  4-1-4. Mutual Interference Prevention		
Cascade Connection	Number of cascaded segments: 3 max.		
	Total number of beams: 255 max. Cable length between sensors: 10 m max. (not including cascading cable (F39-JGR2WTS) and power cable)		
Test Function	Self-test (at power-on, and during operation) External test (light emission stop function by test input)		
Safety-Related Functions	Interlock External device monitoring (EDM) Pre-reset Fixed blanking/Floating blanking Reduced resolution Muting/Override Scan code selection PNP/NPN selection Response time adjustment  Chapter 2 System Operation and Functions		
Environmental			
Ambient Temperature	Operating	-10 to 55°C (14 to 131°F) (non-icing)	
	Storage	-25 to 70°C (-13 to 158°F)	
Ambient Humidity	Operating	35% to 85% (non-condensing)	
	Storage	35% to 95%	
Ambient Illuminance	Incandescent lamp: 3,000 lx max. on receiver surface Sunlight: 10,000 lx max. on receiver surface		
Degree of Protection (IEC 60529)	IEC 60529: IP65 and IP67, JIS C 0920 Annex 1: IP67G		
Vibration Resistance (IEC 61496-1)	10 to 55 Hz, Multiple amplitude of 0.7 mm, 20 sweeps for all 3 axes		
Shock Resistance (IEC 61496-1)	100 m/s ² , 1000 shocks for all 3 axes		
Pollution Degree (IEC 60664-1)	Pollution Degree 3		
Connections			
Power cable	Type of Connection	M12 connectors: 8-pin emitter and receiver. Cables prewired to the sensors. IP67 and IP67G (JIS C 0920 Annex 1)* rated when mated. *F3SG-RR meets the degree of protection when it is correctly connected with an F39-JD□□RA-□ Oil-resistant cable.	
	Number of Wires	Emitter: 5, Receiver: 8	
	Cable Length	0.3 m	
	Cable Diameter	6 mm	
	Minimum Bending Radius	R36 mm	

		F3SG-4RR□□□□-14	F3SG-4RR□□□□-25
Cascading cable	Type of Connection	M12 connectors: 8-pin emitter and receiver. IP67 rated when mated.	
	Number of Wires	Emitter: 5, Receiver: 8	
	Cable Length	0.3 m	
	Cable Diameter	6 mm	
	Minimum Bending Radius	R5 mm	
F39-JD□RA-□ Oil-resistant cable - Single-ended cable	Type of Connection	M12 connectors: 8-pin emitter and receiver. Cables prewired to the sensors. IP67 and IP67G (JIS C 0920 Annex 1)* rated when mated. *F3SG-RR meets the degree of protection when it is correctly connected with the power cable. The degree of protection is not satisfied with the part where cable wires are uncovered.	
	Number of Wires	Emitter: 5, Receiver: 8	
	Cable Length	 4-5-3-1. <i>Single-Ended Cable (Oil-Resistant Cable)</i>	
	Cable Diameter	6 mm	
	Minimum Bending Radius	R36 mm	
Extension cable - Single-ended cable (F39-JD□A) - Double-ended cable (F39-JD□B)	Type of Connection	M12 connectors: 8-pin emitter and receiver. IP67 rated when mated.	
	Number of Wires	Emitter: 8, Receiver: 8	
	Cable Length	 4-5-3-2. <i>Single-Ended Cable</i>  4-5-3-3. <i>Double-Ended Cable</i>	
	Cable Diameter	6.6 mm	
	Minimum Bending Radius	R36 mm	
Extension of Power Cable	100 m max. (Emitter/Receiver)		
Material			
Material	Housing: Aluminum alloy Cap: PBT resin Front window: Acrylic resin Cable: Fluororesin cable FE plate: Stainless steel		
Weight	 1-6. <i>List of Models</i>		
Included Accessories	Safety Precautions, Quick Installation Manual, Troubleshooting Guide Sticker, Warning Zone Label, End Cap (for switching External Test Input function)		
Conformity			
Conforming standards	 <i>Legislation and Standards</i>		
Performance Level (PL)/ Safety category	PL e/Category 4 (EN ISO 13849-1:2015)		
PFF _D	1.1 × 10 ⁻⁸ (IEC 61508)		
Proof test interval T _M	Every 20 years (IEC 61508)		
SFF	99% (IEC 61508)		
HFT	1 (IEC 61508)		
Classification	Type B (IEC 61508-2)		

1-6. List of Models

1-6-1. List of Models/Response Time/Current Consumption/Weight

■ F3SG-4RR□□□□-14

Model	Number of Beams	Protective Height [mm] (Overall length)	Response Time[ms] *1			Current Consumption [mA]		Weight [kg]	
			ON→OFF *2	OFF (Synchronized) →ON *3	OFF (Not synchronized) →ON *3	Emitter	Receiver	Net *4	Gross *5
F3SG-4RR0240-14	23	240	8	40	140	45	75	0.7	1.5
F3SG-4RR0320-14	31	320	8	40	140	55	75	0.9	1.7
F3SG-4RR0400-14	39	400	8	40	140	60	80	1.1	2.0
F3SG-4RR0480-14	47	480	13	65	165	50	80	1.3	2.3
F3SG-4RR0560-14	55	560	13	65	165	55	80	1.5	2.5
F3SG-4RR0640-14	63	640	13	65	165	60	85	1.7	2.8
F3SG-4RR0720-14	71	720	13	65	165	65	85	1.9	3.1
F3SG-4RR0800-14	79	800	13	65	165	65	90	2.1	3.4
F3SG-4RR0880-14	87	880	13	65	165	70	90	2.4	3.6
F3SG-4RR0960-14	95	960	13	65	165	75	90	2.6	3.9
F3SG-4RR1040-14	103	1040	13	65	165	80	95	2.8	4.2
F3SG-4RR1120-14	111	1120	13	65	165	85	95	3.0	4.4
F3SG-4RR1200-14	119	1200	13	65	165	90	100	3.2	4.7
F3SG-4RR1280-14	127	1280	13	65	165	95	100	3.4	5.0
F3SG-4RR1360-14	135	1360	13	65	165	95	105	3.6	5.3
F3SG-4RR1440-14	143	1440	18	90	190	85	105	3.8	5.5
F3SG-4RR1520-14	151	1520	18	90	190	90	105	4.0	5.8
F3SG-4RR1600-14	159	1600	18	90	190	90	110	4.2	6.1
F3SG-4RR1680-14	167	1680	18	90	190	95	110	4.4	6.3
F3SG-4RR1760-14	175	1760	18	90	190	100	115	4.6	6.6
F3SG-4RR1840-14	183	1840	18	90	190	100	115	4.8	6.9
F3SG-4RR1920-14	191	1920	18	90	190	105	120	5.0	7.2

*1. The maximum speed of movement of a test rod up to which the detection capability is maintained is 2.0 m/s.

*2. The response times are values when Scan Code is set at Code B. The response times for Code A are 1 ms shorter than these values.

*3. Refer to 2-3. *Optical Synchronization* for more information.

*4. The net weight is the weight of an emitter and a receiver.

*5. The gross weight is the weight of an emitter, a receiver, included accessories and a package.

■ F3SG-4RR□□□□-25

Model	Number of Beams	Protective Height [mm] (Overall length)	Response Time[ms] *1			Current Consumption [mA]		Weight [kg]	
			ON→OFF *2	OFF (Synchronized) →ON *3	OFF (Not synchronized) →ON *3	Emitter	Receiver	Net *4	Gross *5
F3SG-4RR0240-25	12	240	8	40	140	35	75	0.7	1.6
F3SG-4RR0320-25	16	320	8	40	140	40	75	0.9	1.9
F3SG-4RR0400-25	20	400	8	40	140	45	75	1.1	2.1
F3SG-4RR0480-25	24	480	8	40	140	50	75	1.3	2.4
F3SG-4RR0560-25	28	560	8	40	140	50	75	1.5	2.7
F3SG-4RR0640-25	32	640	8	40	140	55	75	1.7	3.0
F3SG-4RR0720-25	36	720	8	40	140	60	80	1.9	3.2
F3SG-4RR0800-25	40	800	8	40	140	65	80	2.1	3.5
F3SG-4RR0880-25	44	880	13	65	165	50	80	2.3	3.8
F3SG-4RR0960-25	48	960	13	65	165	50	80	2.5	4.0
F3SG-4RR1040-25	52	1040	13	65	165	55	80	2.7	4.3

Model	Number of Beams	Protective Height [mm] (Overall length)	Response Time[ms] *1			Current Consumption [mA]		Weight [kg]	
			ON→OFF *2	OFF (Synchronized) →ON *3	OFF (Not synchronized) →ON *3	Emitter	Receiver	Net *4	Gross *5
F3SG-4RR1120-25	56	1120	13	65	165	55	85	2.9	4.6
F3SG-4RR1200-25	60	1200	13	65	165	55	85	3.1	4.9
F3SG-4RR1280-25	64	1280	13	65	165	60	85	3.3	5.1
F3SG-4RR1360-25	68	1360	13	65	165	60	85	3.5	5.4
F3SG-4RR1440-25	72	1440	13	65	165	65	85	3.7	5.7
F3SG-4RR1520-25	76	1520	13	65	165	65	90	3.9	5.9
F3SG-4RR1600-25	80	1600	13	65	165	70	90	4.1	6.2
F3SG-4RR1680-25	84	1680	13	65	165	70	90	4.3	6.5
F3SG-4RR1760-25	88	1760	13	65	165	70	90	4.5	6.7
F3SG-4RR1840-25	92	1840	13	65	165	75	90	4.7	7.0
F3SG-4RR1920-25	96	1920	13	65	165	75	95	4.9	7.3

*1. The maximum speed of movement of a test rod up to which the detection capability is maintained is 2.0 m/s.

*2. The response times are values when Scan Code is set at Code B. The response times for Code A are 1 ms shorter than these values.

*3. Refer to 2-3. *Optical Synchronization* for more information.

*4. The net weight is the weight of an emitter and a receiver.

*5. The gross weight is the weight of an emitter, a receiver, included accessories and a package.

1-6-2. Calculation of Response Time of Cascaded Segments

The F3SG-RR can be used in cascade connection.

In case of a cascade connection, a response time is determined by the total number of beams.

If the total number of beams of all F3SG-RR in a cascade connection is 140 or less, its response time is 12 ms (Code A)/13 ms (Code B). The number of beams of respective F3SG-RR, however, must be 112 or less. If an F3SG-RR with 113 or more beams is included in the cascade connection, its response time is 17 ms (Code A)/18 ms (Code B).

The diagram below summarizes the relation described above.

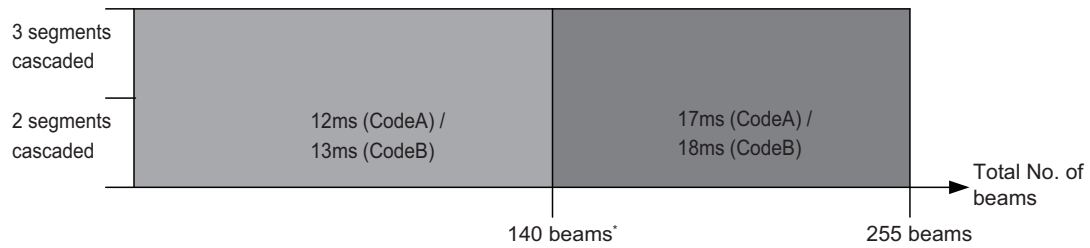

* The number of beams of each segment in cascaded connection must be 112 or less.

 2-4. Scan Code Selection

 4-2. Cascade Connection

Chapter 2 System Operation and Functions

2-1. Combination of Functions	16
2-2. Operating States	18
2-3. Optical Synchronization	19
2-4. Scan Code Selection	20
2-5. PNP/NPN Selection	21
2-6. Self-Test	22
2-7. External Test	24
2-8. Lockout Reset	26
2-9. Interlock	27
2-10. External Device Monitoring (EDM)	32
2-11. Auxiliary Output	35
2-12. Muting	38
2-13. Override	63
2-14. Fixed Blanking	70
2-15. Floating Blanking	74
2-16. Reduced Resolution	79
2-17. Warning Zone	82
2-18. Setting Zone Adjacency Conditions	86
2-19. Response Time Adjustment	88
2-20. Lamp	89
2-21. Designated Beam Output	92
2-22. Light Level Monitoring	94
2-23. Maintenance Information	95
2-24. Operating Status Monitoring	97
2-25. Setting Recovery	98

2-1. Combination of Functions

Possible combinations of the F3SG-RR functions are shown in the table below. The combinations in the table are available under certain conditions. The other functions can be combined without any limitations.

 Refer to 2-18. *Setting Zone Adjacency Conditions* for further information.

YES: Combination available

NO: Combination unavailable

	Fixed Blanking	Floating Blanking	Reduced Resolution	Muting/Override	Pre-Reset	Warning Zone	EDM	Interlock
Fixed Blanking	-	YES *2	NO	YES	NO	YES	YES	YES
Floating Blanking	YES *2	-	NO	YES *1	NO	YES	YES	YES
Reduced Resolution	NO	NO	-	NO	YES	NO	YES	YES
Muting/Override	YES	YES *1	NO	-	NO	YES	YES	YES
Pre-Reset	NO	NO	YES	NO	-	YES	YES	NO
Warning Zone	YES	YES	NO	YES	YES	-	YES	YES
EDM	YES	YES	YES	YES	YES	YES	-	YES
Interlock	YES	YES	YES	YES	NO	YES	YES	-

*1.This combination requires that the Floating Blanking zone covers the full detection zone and that the Muting/Override function also covers the full detection zone.

*2.When the Fixed Blanking and Floating Blanking are selected, the top or bottom beam must be included in the Fixed Blanking zone, as shown in the left figure below. It is not allowed to set the Fixed Blanking zone not to cover the top or bottom beam, as shown in the right figure below. It is also not allowed to set a Fixed Blanking zone to split a Floating Blanking zone.

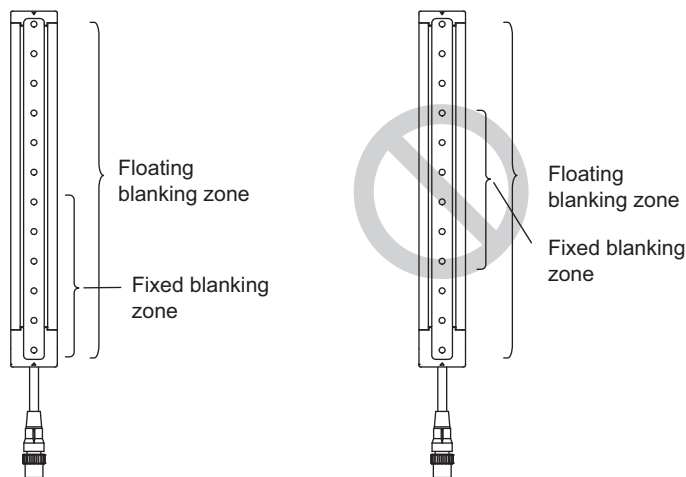

■ Considerations for enabling and disabling Muting function

Setting parameters of the following functions can be saved according to the state where the Muting function is enabled and disabled, respectively. After changing the Muting function from Enable to Disable or from Disable to Enable, check the settings of these functions again.

Affected functions:

- External Device Monitoring (EDM)
- Start Interlock
- Restart Interlock
- Auxiliary Output
- Lamp Output



Refer to the Setting with Configuration Tool sections of the affected functions in *Chapter 2 System Operation and Functions* for more information on the setting parameters.

2-2. Operating States

The operating condition of a F3SG-RR system is described in terms of states. The following operating states exist for a F3SG-RR system.

2-2-1. Machine Run State

The two receiver safety outputs are in the ON state, the green ON/OFF indicator is illuminated. The protected machine is allowed to operate. Pressing and releasing the reset switch has no effect.

2-2-2. Machine Stop State

The two receiver safety outputs are in the OFF state, the red ON/OFF indicator is illuminated. The protected machine is not allowed to operate.

2-2-3. Interlock State

The two receiver safety outputs are in the OFF state, yellow Interlock indicator is illuminated. The Interlock state does not allow the protected machine to operate until the detection zone is clear of obstructions and the reset switch is pressed and released.



Refer to 2-9. *Interlock* for more information.

2-2-4. Lockout State

The two receiver safety outputs are in the OFF state, the red Lockout indicator is blinking, and another indicator is blinking showing an error. The Lockout state does not allow the protected machine to operate. The primary difference between Lockout and Interlock states is that the F3SG-RR system will remain in the Lockout state until the cause of the error is corrected, regardless of power cycling or an external reset switch press and release.

2-2-5. Setting State

The two receiver safety outputs are in the OFF state. The blue Top-beam-state indicator, green Configuration indicator, red Lockout indicator, green Stable-state indicator and green ON/OFF indicator of the receiver are blinking. The Setting state does not allow the protected machine to operate. The user can change settings of the functions, monitor the operating states or view maintenance information with the Configuration Tool (SD Manager 2) under this state.



Refer to *Safety Light Curtain Configuration Tool for Model F3SG (SD Manager 2) User's Manual* for more information.

2-3. Optical Synchronization

2-3-1. Overview

Synchronization is required between an emitter and a receiver for normal operation of F3SG-RR. F3SG-RR uses a specific beam for Synchronization. The beam is hereinafter called synchronization beam.

Depending on sensor configuration, the synchronization beam is either of the followings:

- One segment system: End beams (Top or Bottom beam)
- Cascaded system* : End beams (Top or Bottom beam) of the primary sensor

For an emitter and a receiver to synchronize, at least one synchronization beam must be unblocked.

The synchronization process is performed when:

- (1) The power is turned on for an emitter and a receiver
- (2) All beams of the primary sensor are blocked and then unblocked
- (3) Synchronization is lost due to an error such as noise and ambient light



The sensor can maintain the synchronization in other cases than those described above and it is not necessary to keep the synchronization beam unblocked all the time.

CHECK!

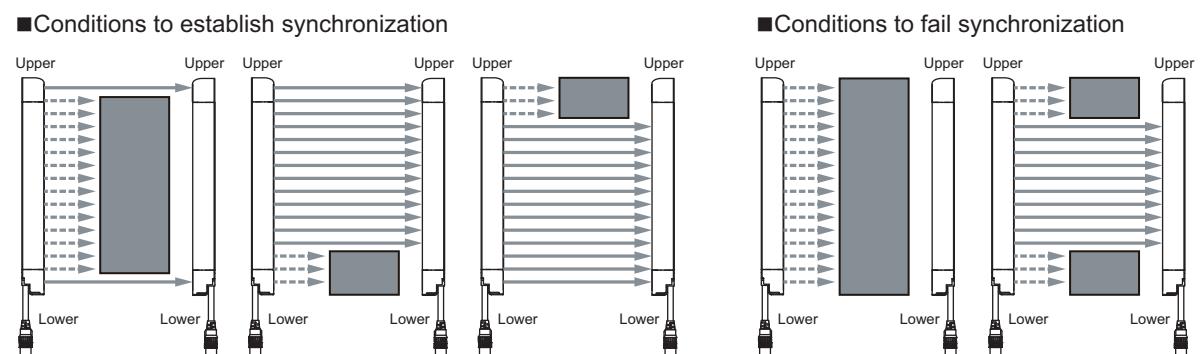

■ Response time of “OFF (Synchronized) → ON” and “OFF (Not synchronized) → ON”

Response time of “OFF (Synchronized) → ON” is the response time from when the F3SG-RR is in the OFF state and the emitter and receiver are synchronized to when the F3SG-RR is turned to the ON state.

Response time of “OFF (Not synchronized) → ON” is the response time from when the F3SG-RR is in the OFF state and the emitter and receiver are not synchronized to when the F3SG-RR is turned to the ON state. This response time is longer since the F3SG-RR evaluates if it is blocked or unblocked, after the synchronization is established.

2-4. Scan Code Selection

2-4-1. Overview

The F3SG-RR has two scan codes (Code A and Code B). These scan codes have different internal processing time. The use of different scan codes allows for placement of systems in close proximity and in line with each other and minimize mutual interference.

The response time for Code A is 1 ms shorter than that for Code B.

 1-6-1. *List of Models/Response Time/Current Consumption/Weight* for more information on the response time.

 Refer to 4-1-4. *Mutual Interference Prevention* for how to mitigate mutual interference.

2-4-2. Factory Default Setting

The factory default setting is Code A.

 Both the emitter and receiver units must be set to the same code.
CHECK!

2-4-3. Setting

The user can select the scan code from Code A or Code B by the Rotary Switch.

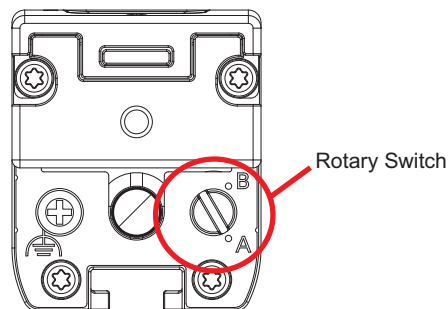

 Refer to *Chapter 3 Setting with Rotary Switch and End Cap* for more information on setting this function by the Rotary Switch or End Cap Switch.

2-4-4. Setting with Configuration Tool

The user cannot make any changes to the scan code by the Configuration Tool.

2-5. PNP/NPN Selection

2-5-1. Overview

The F3SG-RR offers PNP/NPN selection for the user to select the polarity of the inputs and outputs of the receiver between PNP and NPN.

When the system is set to the NPN type, the “NPN” indicator is illuminated.

2-5-2. Factory Default Setting

The factory default setting is PNP type.

2-5-3. Setting with Configuration Tool

WARNING

Some settings of functions or the Setting Recovery function configurable with the configuration Tool may increase risks. Make sure the Responsible Person conduct a thorough risk assessment analysis before managing and changing the settings. Unintended changes to the settings may cause a person go to undetected, resulting in serious injury.



The user can make changes to the settings by the Configuration Tool.

Function	Factory Default Setting	Available Parameters
PNP/NPN Selection	PNP	PNP/NPN



Refer to *Safety Light Curtain Configuration Tool for Model F3SG (SD Manager 2) User's Manual* for more information on setting this function by the Configuration Tool.

2-6. Self-Test

2-6-1. Overview

The F3SG-RR performs the Self-Test when power is turned ON (within 2 seconds) to check for errors. Also, it regularly performs the Self-Test (within a response time) while operating.

This function cannot be cancelled.

■ Timing chart

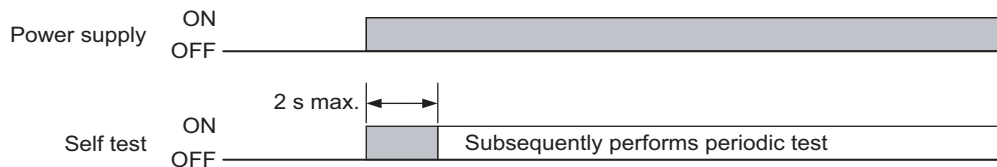

If an error is found in the Self-Test, the F3SG-RR enters the Lockout state, keeps the safety output in the OFF state, and indicates the error at the same time.

2-6-1-1. Self-Test details

The Self-Test detects such error as described below.

Emitter

- Failure of emitter unit or circuit
- CPU failure
- Memory failure
- Failure of Rotary Switch*
- Failure of End Cap

Receiver

- Abnormal external power supply voltage
- Failure of internal power supply circuit
- Failure of receiver unit or detection circuit
- CPU failure
- Memory failure
- Failure of safety output circuit
- Disconnected or short-circuited cable
- Failure of Rotary Switch*
- Failure of End Cap

2-6-1-2. Waveform of safety outputs

When the safety outputs are in the ON state, they are cyclically turned OFF as shown below to test the output circuit. When this OFF signal is fed back, the output circuit is diagnosed as normal. If the output signal does not include an OFF pulse signal due to short-circuit, etc, the receiver diagnoses a failure in the output circuit or wiring, and it enters the Lockout state.

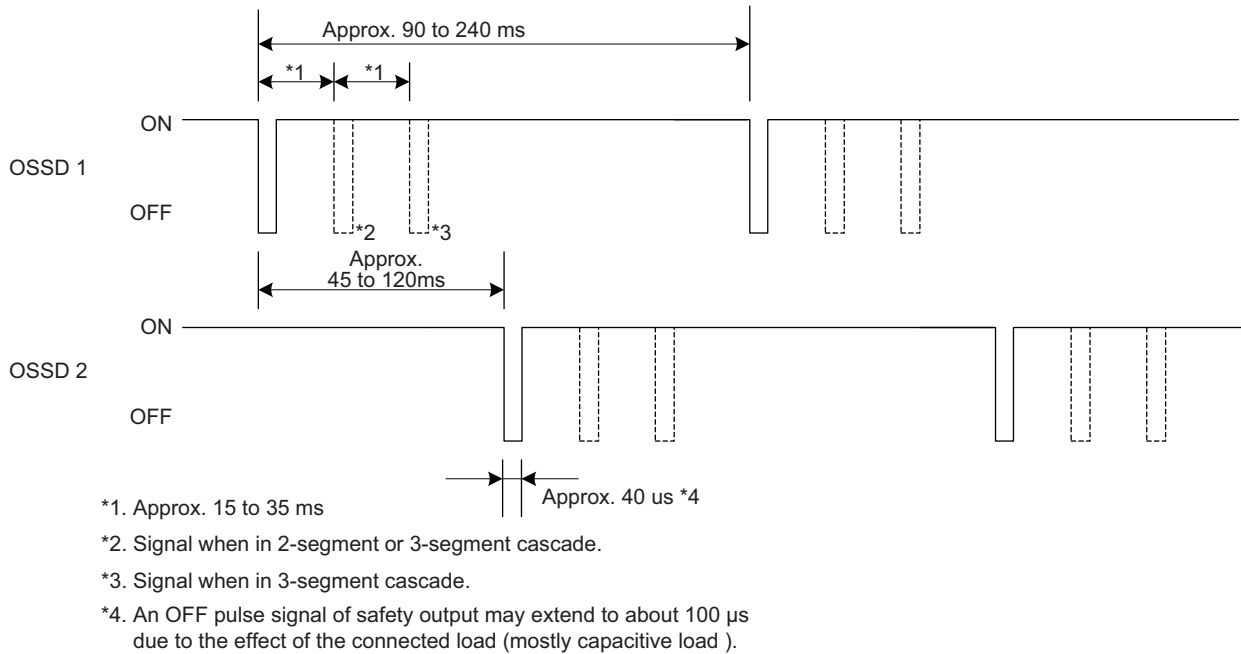

2-7. External Test

2-7-1. Overview

This function stops the emission using an external signal. It can be used to verify that a safety system should properly stop (safety output turns OFF) when F3SG-RR is blocked.

To stop the emission, apply the following voltage to the emitter's TEST input line according to the End Cap settings of the emitter.



When the Muting is active, the safety outputs are kept in the ON state even if the emission is stopped.

CHECK!

End Cap settings	24 V Active	0 V Active
Input voltage	9 V to V_s	0 to 3 V
End Cap	Black	White

Basic wiring diagram

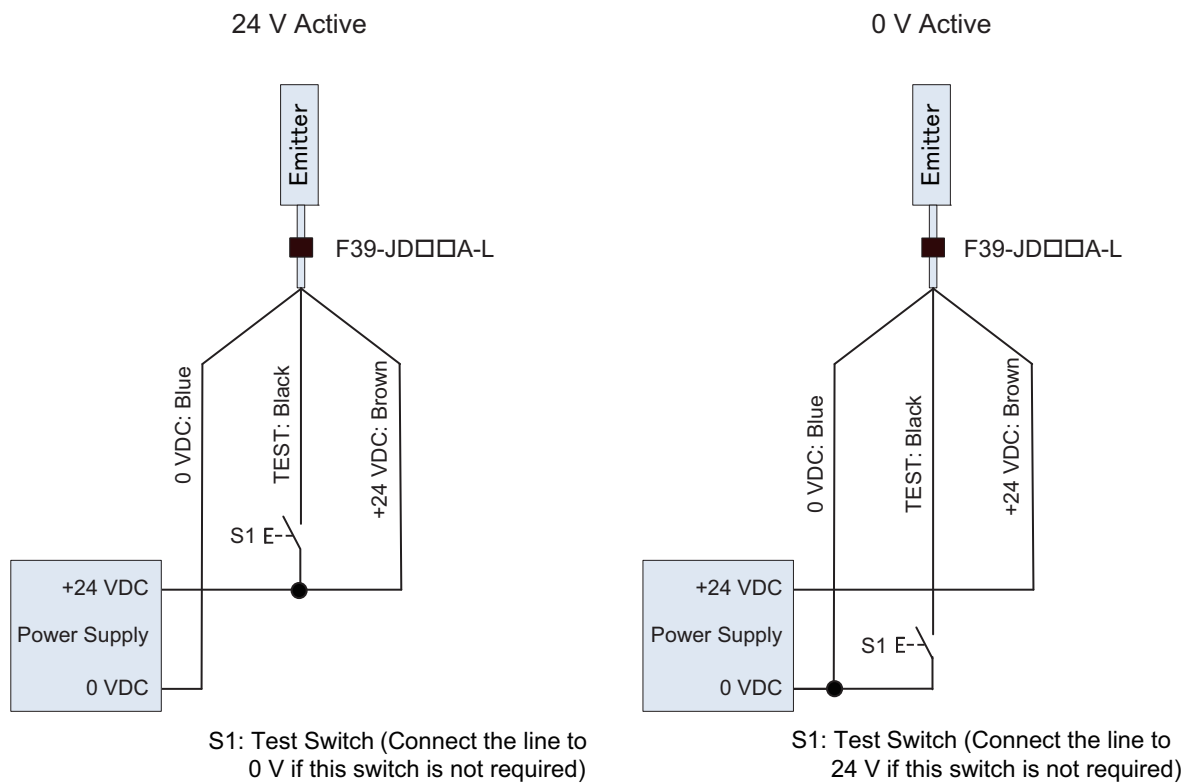

Timing chart



Toff: Response time ON to OFF

2-7-2. Factory Default Setting

The factory default setting is 24 V Active with the black End Cap attached to the F3SG-RR.

2-7-3. Setting

The user can select the setting from 24 V Active or 0 V Active by switching the End Cap.



Refer to *Chapter 3 Setting with Rotary Switch and End Cap* for more information on setting this function by the Rotary Switch.

2-7-4. Setting with Configuration Tool

The user cannot make any changes to the External Test settings by the Configuration Tool.

2-8. Lockout Reset

2-8-1. Overview

When the cause of the Lockout is removed, you can release the Lockout state of the F3SG-RR by using either of the following methods.

- Cycle the power back ON
- Reset input

The resetting method by the Reset input depends on the setting of PNP/NPN Selection as follows.

PNP	NPN
Open or apply 0 V to 1/2 Vs to the EDM line (red) for 1 s or longer, and then apply a voltage of Vs-3 V to Vs again.	Open or apply 1/2 Vs to Vs to the EDM line (red) for 1 s or longer, and then apply a voltage of 0 to 3 V again.

■ Basic wiring diagram

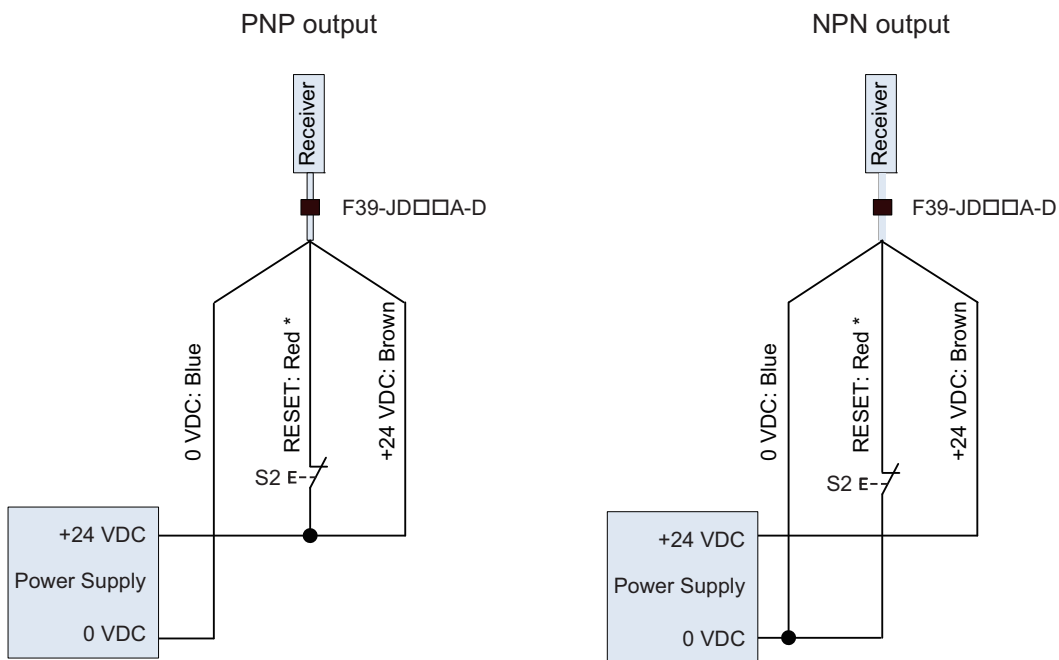

S2: Lockout Reset Switch (Also used as Interlock Reset Switch in Manual Reset mode.)
 *Also used as Lockout Reset input line.

■ Timing chart

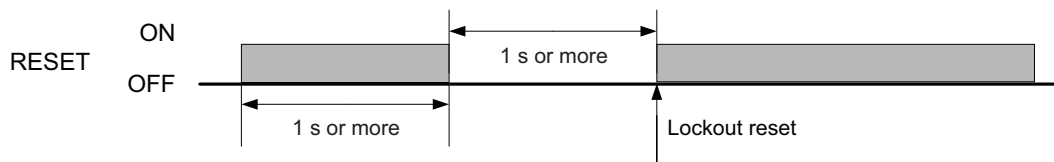

The table below shows the relation between the ON/OFF states and external lines.

Input	External Connection	
	PNP	NPN
ON	Vs-3 V to Vs	0 to 3 V
OFF	0 V to 1/2 Vs, or open	1/2 Vs to Vs, or open

2-9. Interlock

WARNING

Install the reset switch in a location that provides a clear view of the entire hazardous zone and where it cannot be activated from within the hazardous zone.



Install the pre-reset switch always in the hazardous zone and where it cannot be activated from outside the hazardous zone.



2-9-1. Overview

The F3SG-RR turns the safety outputs OFF when its power is turned on or the F3SG-RR is blocked and holds this state until a reset signal is received. This state is called "Interlock state". The function to keep the Interlock state is called "Interlock function".

The F3SG-RR has two Interlock functions, Start Interlock and Restart Interlock.

- **Start Interlock**

The F3SG-RR turns the safety output OFF at power-on or recovery from power failure and keep this state until a reset signal is received. This is useful if you want to keep the machine stopped until a pre-operation check is completed after the power is turned ON.

- **Restart Interlock**

The F3SG-RR turns the safety output OFF when the F3SG-RR is blocked and keep this state until a reset signal is received. Restart interlock is useful if you want to restart the machine being stopped upon interruption of the F3SG-RR, only after the operator confirms a safe condition.

The F3SG-RR offers three ways to reset the Interlock state: Auto Reset, Manual Reset, and Pre-Reset applicable to specific applications.

- **Auto Reset mode**

Auto Reset mode disables the Start Interlock and Restart Interlock. When the interrupting object is removed from the detection zone, the Interlock state is automatically released and the safety outputs are automatically turned ON. Auto Reset is desirable for application where a worker is not able to enter the area between the detection zone and the hazardous part of the machine or you use a relay unit to activate Start Interlock and Restart Interlock.

- **Manual Reset mode**

Manual Reset mode enables the Start Interlock and Restart Interlock. When a reset signal is given while no interrupting object exists in a detection zone, the safety outputs are turned ON.

- **Pre-Reset mode**

An operator may enter and work in the hazardous zone for maintenance.

Under such a circumstance, another operator may press the reset switch to restart the machine without recognizing the operator working in the hazardous zone, posing a danger. The Pre-Reset function ensures safety for an operator working in the hazardous zone by adding another reset switch (pre-reset switch) in the hazardous zone.

If the Pre-Reset function is enabled, an operator can work in the hazardous zone and press the pre-reset switch installed in the hazardous zone, pass the light curtain, and press the reset switch to restart the machine.

Shown below is overview of restarting the machine using the Pre-Reset.

1. Press the Pre-Reset switch (Input PRE-RESET signal)
2. Pass and interrupt F3SG-RR
3. Press the Reset switch to restart the system (Input RESET signal)

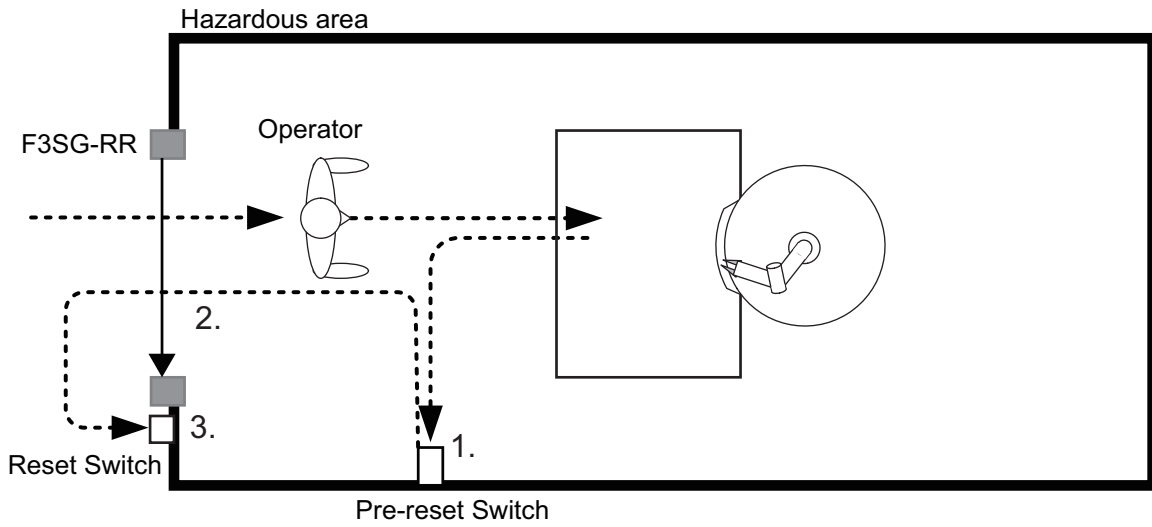

Refer to 2-1. *Combination of Functions* for more information on the use in conjunction with other functions.

Basic wiring diagram

- Auto Reset mode

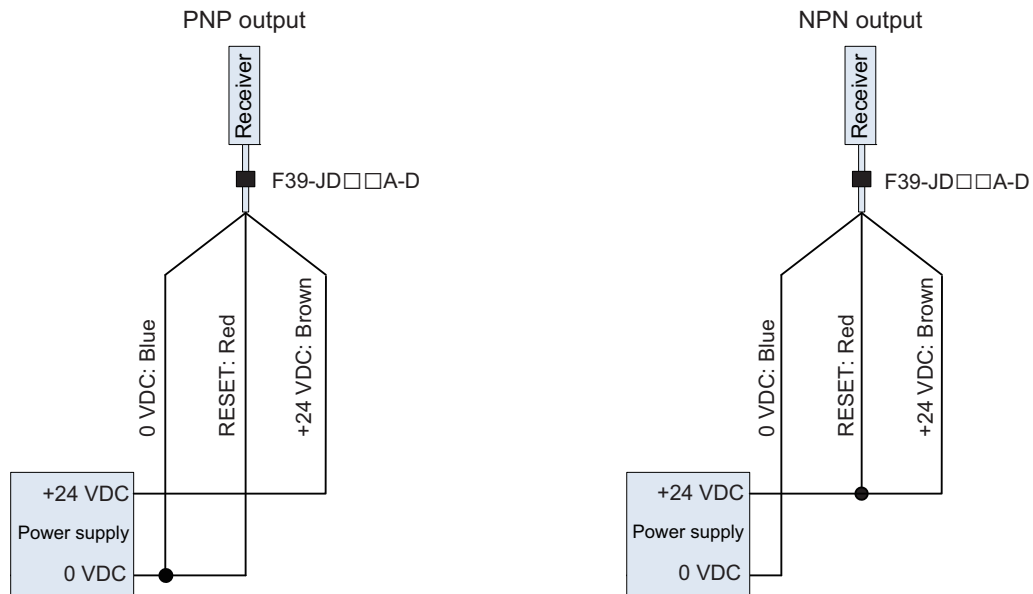

• Manual Reset mode

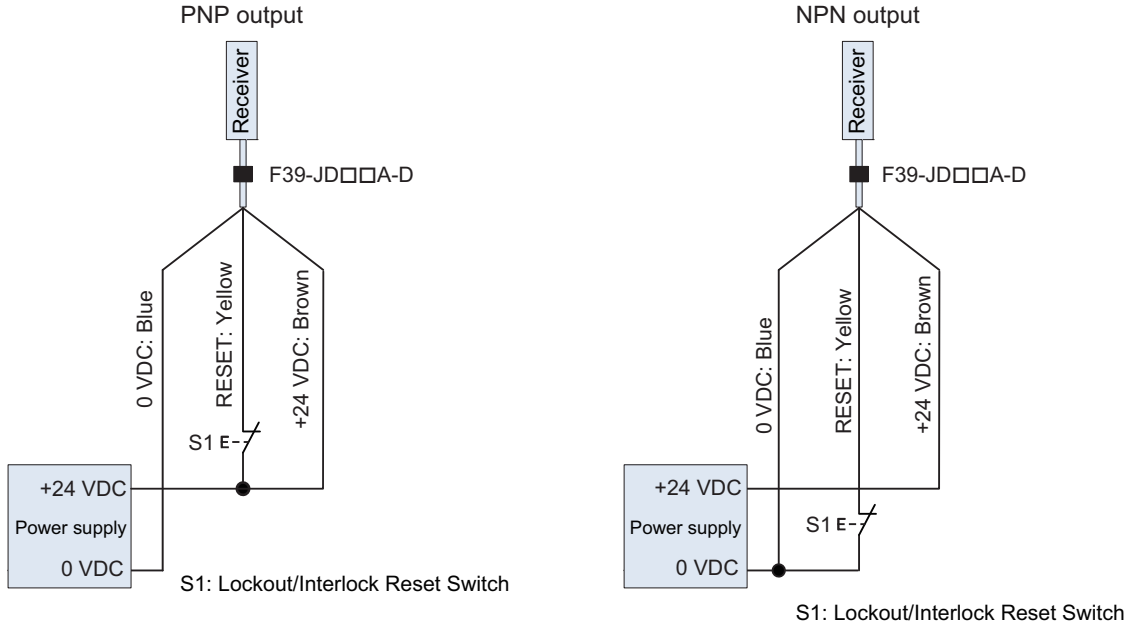

The table below shows the relation between the ON/OFF states and external lines.

Input	External Connection	
	PNP	NPN
ON	$V_s - 3\text{ V}$ to V_s	0 to 3 V
OFF	0V to $1/2 V_s$, or open	$1/2 V_s$ to V_s , or open

■ Timing chart

• Start Interlock

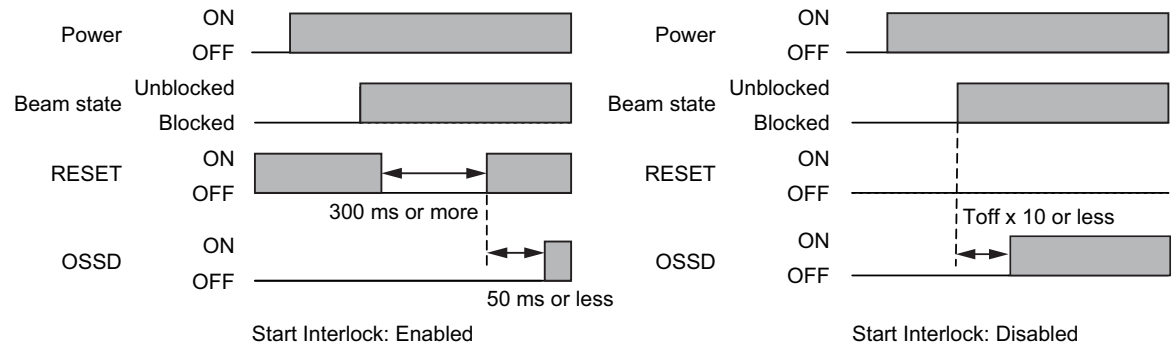

• Restart Interlock

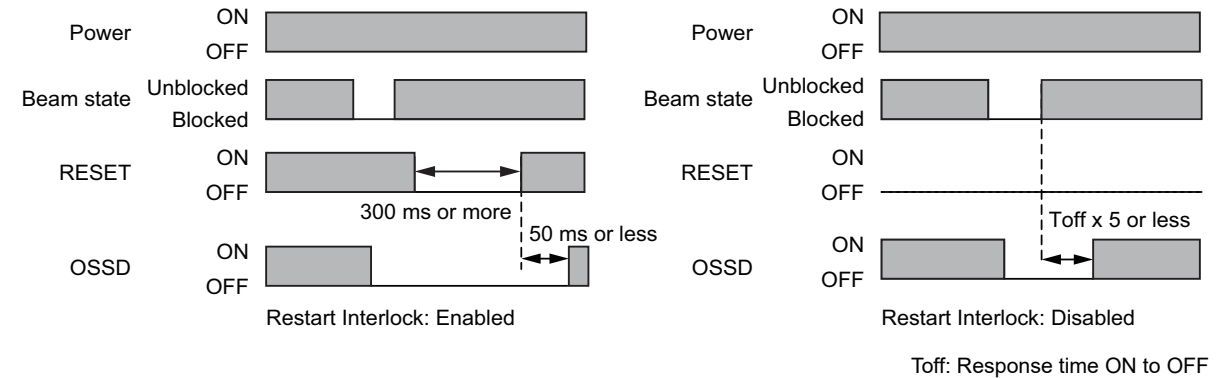

■ Basic wiring diagram

- Pre-Reset mode

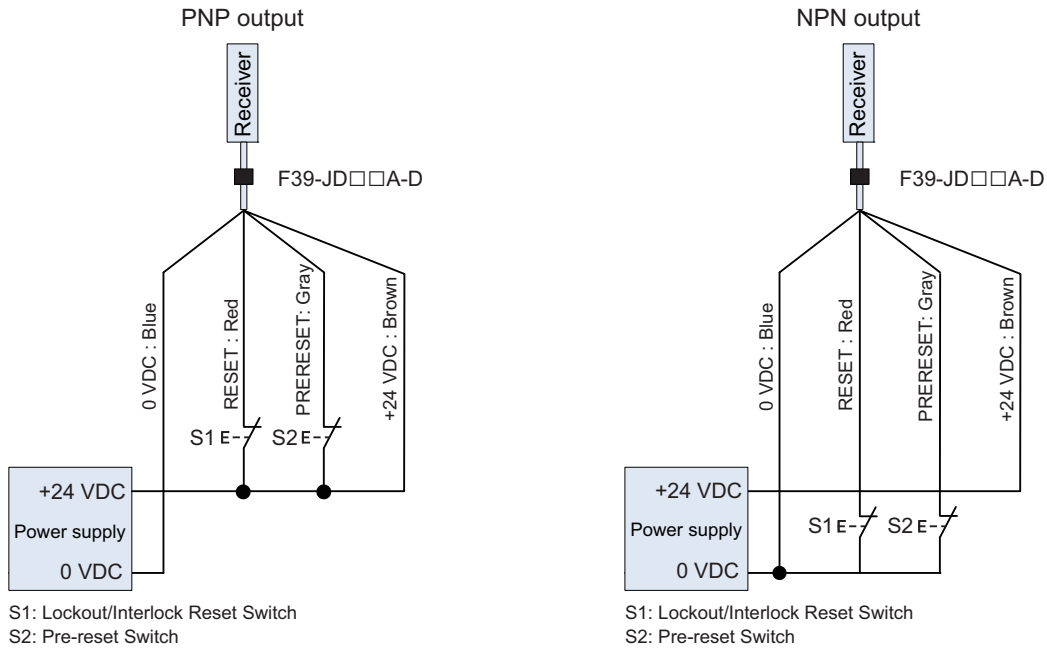

The table below shows the relation between the ON/OFF states and external lines.

Input	External Connection	
	PNP	NPN
ON	Vs-3 V to Vs	0 to 3 V
OFF	0V to 1/2 Vs, or open	1/2 Vs to Vs, or open

■ Timing chart

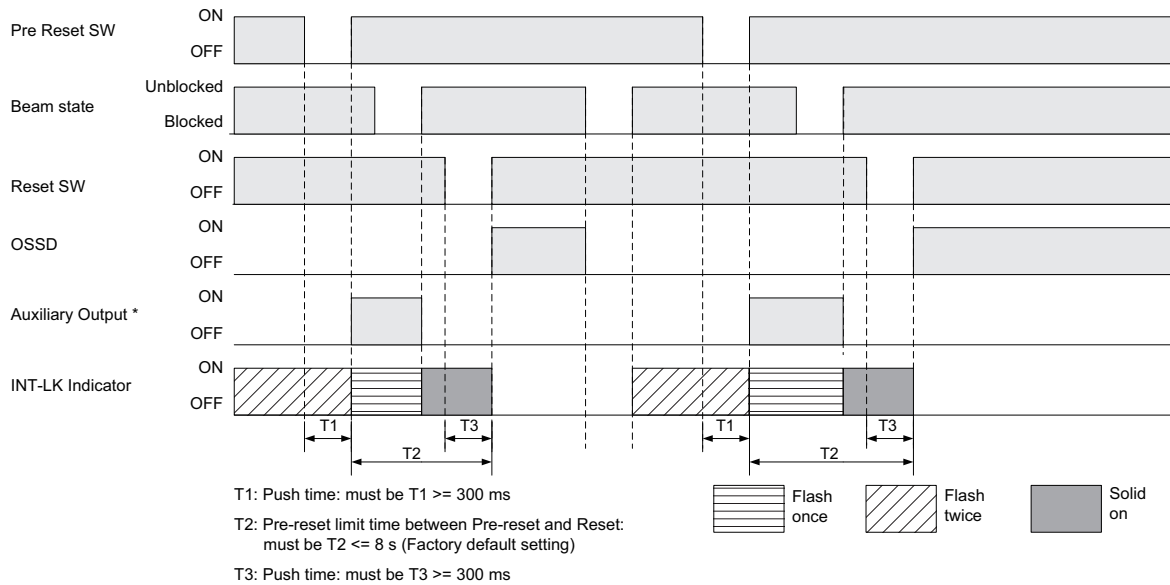

* When Auxiliary Output is set to Pre-Reset Enabled by the Configuration Tool.

2-9-2. Factory Default Setting

The factory default setting is Auto Reset mode enabled.

2-9-3. Setting with Configuration Tool

WARNING

Some settings of functions configurable with the Configuration Tool may increase risks. Make sure the Responsible Person conduct a thorough risk assessment analysis before managing and changing the settings. Unintended changes to the settings may cause a person to go undetected, resulting in serious injury.



The user can make changes to the settings by the Configuration Tool.

Interlock function

Function	Factory Default Setting		Available Parameters
	Muting function enabled*	Muting function disabled*	
Start Interlock	Disable	Disable	Enable/Disable
Restart Interlock	Disable	Disable	Enable/Disable

* Setting parameters of this function can be saved according to the states where the Muting function is enabled and disabled, respectively. After changing the Muting function from Enable to Disable or from Disable to Enable, also check the settings of this function again.

 Refer to ■ *Considerations for enabling and disabling Muting function* under 2-1. *Combination of Functions* for more information.

Pre-Reset function

Function	Factory Default Setting	Available Parameters
Pre-Reset	Disable	Enable*1*2/Disable
Maximum number of times F3SG-RR can be blocked *3	infinite	1 to 9 times in 1-time increments, or infinite
Maximum permissible time from input of PRE-RESET signal to input of RESET signal	8 s	1 to 60 s in 1-s increments

*1. When the Pre-Reset is enabled, it precedes all other interlock functions and the parameters of Start Interlock and Restart Interlock are ignored.

*2. It is not possible to configure the Pre-Reset function together with the Muting function. To enable settings of the Pre-Reset function, disable the Muting function.

In addition, setting parameters of the following functions can be saved according to the states where the Muting function is enabled and disabled, respectively. After changing the Muting function from Enable to Disable or from Disable to Enable, also check the settings of these functions again. Affected functions: External Device Monitoring (EDM), Start Interlock, Restart Interlock, Auxiliary Output, Lamp Output

*3. The minimum number of times is fixed to 1.

 Refer to *Safety Light Curtain Configuration Tool for Model F3SG (SD Manager 2) User's Manual* for more information on setting this function by the Configuration Tool.

2-10. External Device Monitoring (EDM)

2-10-1. Overview

This function monitors if external relays (or contactors) operate normally to detect malfunctions, such as welding, in the external relays. When the NC contact of the external relays is open before the safety outputs switch from OFF to ON, the safety outputs remain in the OFF state. When the NC contact is not open within the allowable delay time after the safety outputs switch from OFF to ON, the F3SG-RR enters the Lockout state.

Perform wiring so that the specified voltage is applied to the RESET input line via the NC contact of the external relays. Refer to the table below for the specified voltage.

The external relays or contactors must have the direct opening mechanism or be force-guided ones.

PNP/NPN	Voltage
PNP	Vs-3 V to Vs
NPN	0 V to 3 V

When the EDM is not used, apply the auxiliary output signal to the EDM line.

Basic wiring diagram

- In Auto Reset mode

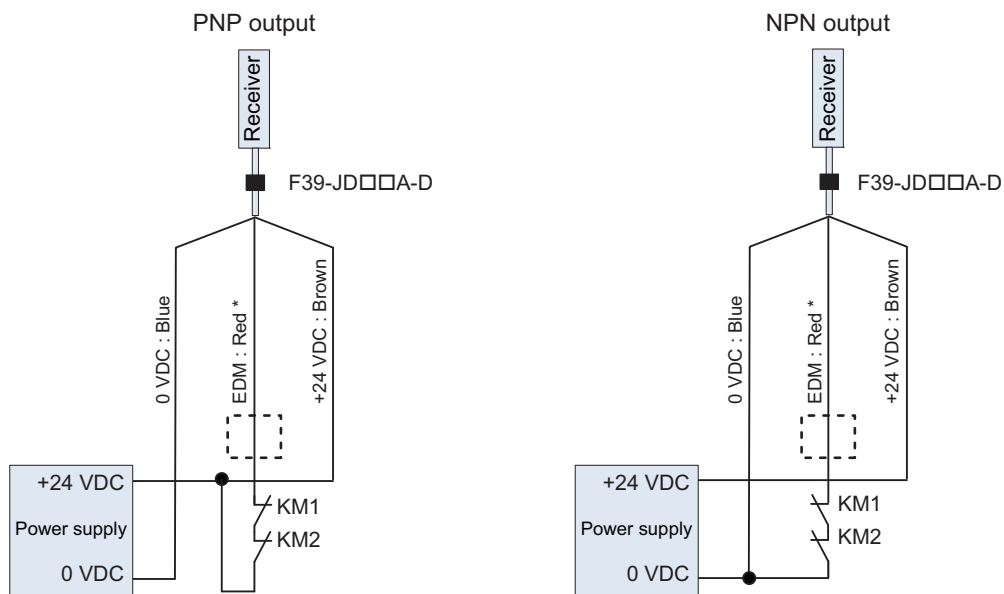

KM1, KM2: External device

* Also used as EDM input line. When using a lockout reset switch, connect an NC contact switch to this line in the position shown by the broken line.

- In Manual Reset mode

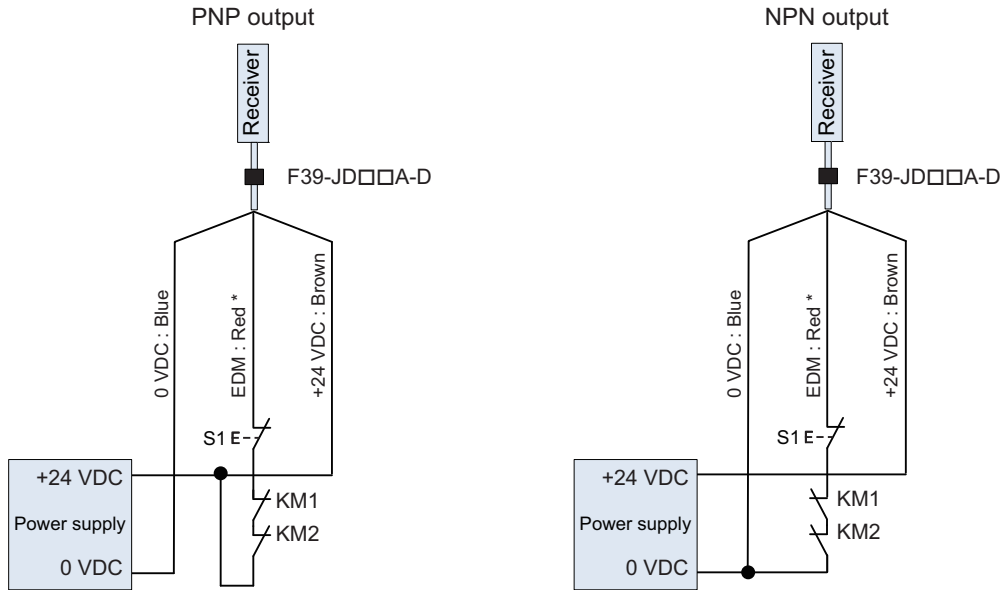

S1: Lockout/Interlock Reset Switch
 KM1, KM2: External device
 *Also used as EDM input line.

■ Timing chart

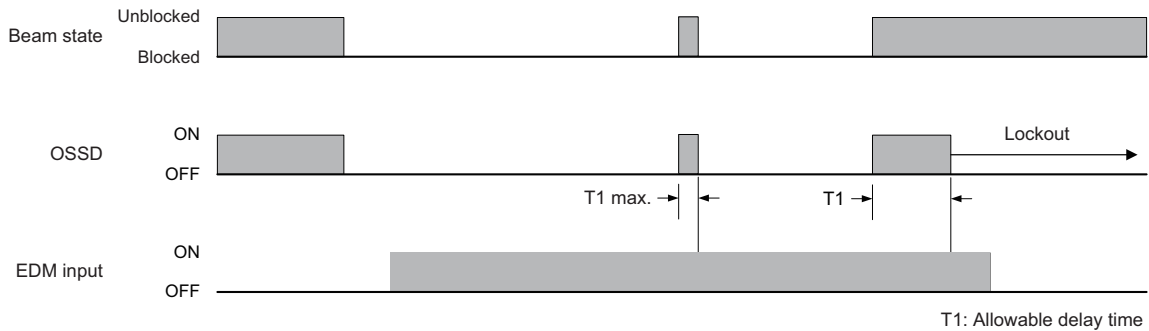

T1: Allowable delay time

2-10-2. Factory Default Setting

The default setting is EDM Enable.

2-10-3. Setting with Configuration Tool

⚠ WARNING

Some settings of functions configurable with the Configuration Tool may increase risks. Make sure the Responsible Person conduct a thorough risk assessment analysis before managing and changing the settings. Unintended changes to the settings may cause a person to go undetected, resulting in serious injury.



The user can make changes to the settings by the Configuration Tool.

Function	Factory Default Setting		Available Parameters
	Muting function enabled*	Muting function disabled*	
EDM	Enable	Enable	Enable/Disable
Allowable delay time	0.3 s	0.3 s	0.1 to 4 s in 0.1-s increments

*Setting parameters of this function can be saved according to the states where the Muting function is enabled and disabled, respectively. After changing the Muting function from Enable to Disable or from Disable to Enable, also check the settings of this function again.



Refer to ■ *Considerations for enabling and disabling Muting function* under 2-1. *Combination of Functions* for more information.



After you make any change to the setting, verify that the F3SG-RR goes to the Lockout state when the F3SG-RR is wired in such a way that the specified voltage is applied directly to the RESET input of the receiver without the NC contact of an external device.

CHECK!



Refer to *Safety Light Curtain Configuration Tool for Model F3SG (SD Manager 2) User's Manual* for more information on setting this function by the Configuration Tool.

2-11. Auxiliary Output

WARNING

Do not use the auxiliary output for safety applications.
Failure to do so may result in serious injury when the F3SG-RR fails.



2-11-1. Overview

The auxiliary output is used to monitor the status of F3SG-RR. This output can be connected to a device such as an indication lamp, programmable controller, etc.

Basic wiring diagram

Shown below are hard wirings for PNP and NPN types, respectively.

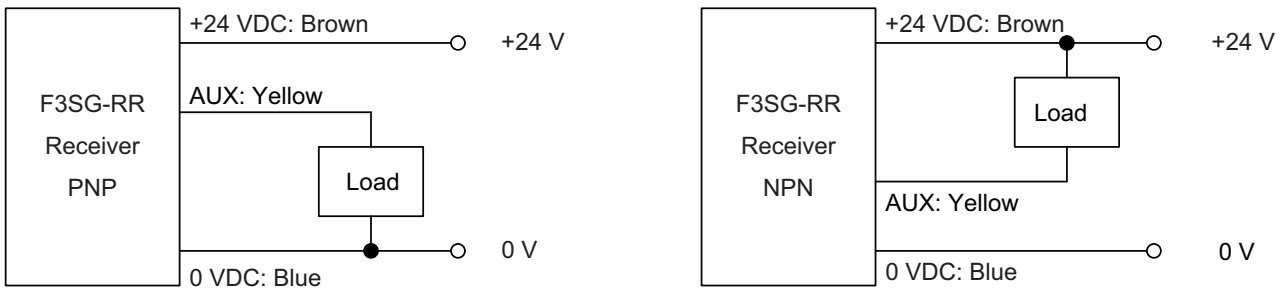

The load current of the auxiliary output is 100 mA max.

2-11-2. Factory Default Setting

The factory default setting is inverted signal of the safety output.

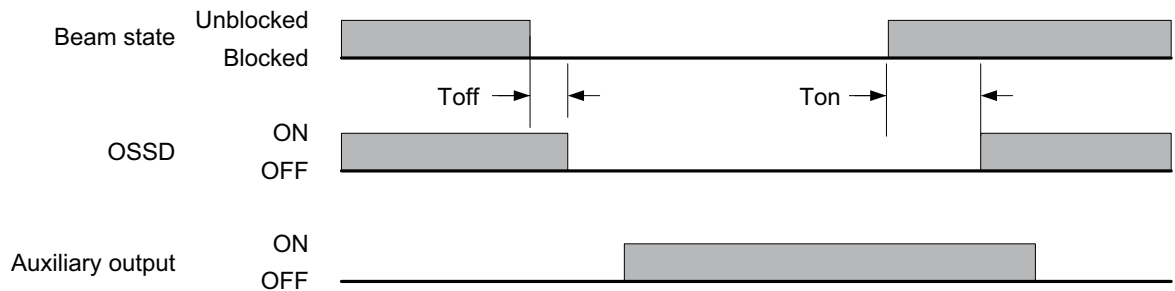

Ton: Response time OFF to ON
Toff: Response time ON to OFF

2-11-3. Setting with Configuration Tool

WARNING

Some settings of functions configurable with the Configuration Tool may increase risks. Make sure the Responsible Person conduct a thorough risk assessment analysis before managing and changing the settings. Unintended changes to the settings may cause a person to go undetected, resulting in serious injury.



The user can make changes to the settings by the Configuration Tool.

- Output operation mode
Information to be allocated to the auxiliary output
- Inverted signal output mode
Auxiliary output gives a inverted signal of the safety output.
- Output pattern
Pattern to send an output signal from the auxiliary output

The user can make changes to the settings by the Configuration Tool.

Function	Factory Default Setting		Available Parameters
	Muting function *1		
	Enabled	Disabled	
Output operation mode	Safety output information	Safety output information	*2
Inverted signal output	Enable	Enable	Enable/Disable
Output pattern	Solid-ON	Solid-ON	Solid-ON/ON 1 time *3

*1. Setting parameters of this function can be saved according to the states where the Muting function is enabled and disabled, respectively. After changing the Muting function from Enable to Disable or from Disable to Enable, also check the settings of this function again.

 Refer to ■ *Considerations for enabling and disabling Muting function* under 2-1. *Combination of Functions* for more information.

 Refer to 2-12. *Muting* for more information on settings of the Muting function.

*2. Refer to the table of Information (Output operation mode) assigned to auxiliary output below.

*3. Output signal is sent according to the patterns as shown in the output pattern chart below.

■ Output pattern chart

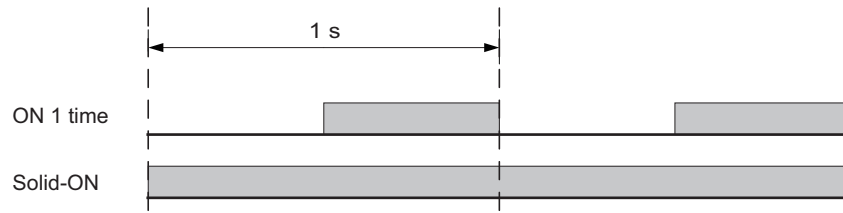

Information (Output operation mode) assigned to auxiliary output

Information Name	Description (Auxiliary output is turned ON under the following condition)
Safety output information	When Safety output is in the ON state
Interlock information	Under Interlock state
Lockout information	Under error/ Lockout state
Excess power-on time information	When power-on time exceeds power-on time threshold
Excess load switching frequency information	When load switching frequency exceeds load switching frequency threshold
Stable-state information	When light intensity, which is consistently monitored, is 170% or higher of ON-threshold
Muting information	Under Muting state
Override information	Under Override state
Muting/Override information	Under either Muting or Override state
Light level diagnosis information	When the F3SG-RR is unblocked and light intensity is within a range from 100% to 170% of ON-threshold for 10 s or longer
Warning Zone Information	When warning zone is blocked
Blanking beam unblocked information	When Fixed-Blanking or Floating Blanking beams are unblocked
Troubleshooting support signal	When one of the signals of Sequence error information, Interference/vibration information and Light level diagnosis information is in the ON state.
Designated beam output information	When a designated beam is blocked or unblocked
Sequence error information	Under Muting sequence error state or Interlock sequence error state
Reset-input information	When Reset/EDM/Override input is in the ON state
Mute A input information	When muting input A input is in the ON state
Mute B input information	When muting input B is in the ON state
EDM input information	When EDM signal input is in the ON state
Individual cascaded sensor output (Channel 1)	When Safety output of Primary sensor in cascade connection is the ON state
Individual cascaded sensor output (Channel 2)	When Safety output of 1st Secondary sensor in cascade connection is the ON state
Individual cascaded sensor output (Channel 3)	When Safety output of the 2nd Secondary sensor in cascade connection is the ON state
Blanking/Warning-zone information	When Fixed Blanking, Floating Blanking, Reduced Resolution or Warning Zone function is enabled
Interference/vibration information	When the F3SG-RR system stops accidentally due to interference or vibration. (In case of cascade connection, when any of cascaded segments comes under this condition.)
Pre-reset Information	Under Pre-reset state

 Refer to *Safety Light Curtain Configuration Tool for Model F3SG (SD Manager 2) User's Manual* for more information on setting this function by the Configuration Tool.

2-12. Muting

2-12-1. Overview

Muting function temporarily disables safety function of the F3SG-RR, keeping safety output ON even if beams are blocked. This makes it possible to install safety light curtains for AGV passage, enabling both safety and productivity. When the Muting is active, the top-beam-state indicator (TOP) and bottom-beam-state indicator (BTM) blink to notify people in the surrounding zone that the safety functions are disabled.

The following three operation modes are available for the muting function.

1. Standard Muting Mode (factory default setting)
2. Exit-Only Muting Mode
3. Position Detection Muting Mode

 Refer to 2-1. *Combination of Functions* for more information on the use in conjunction with other functions.

The following settings are available for a beam range to be the muting state.

- All Range Disabled Setting
- Partially Disabled Setting
- Dynamic Muting Setting

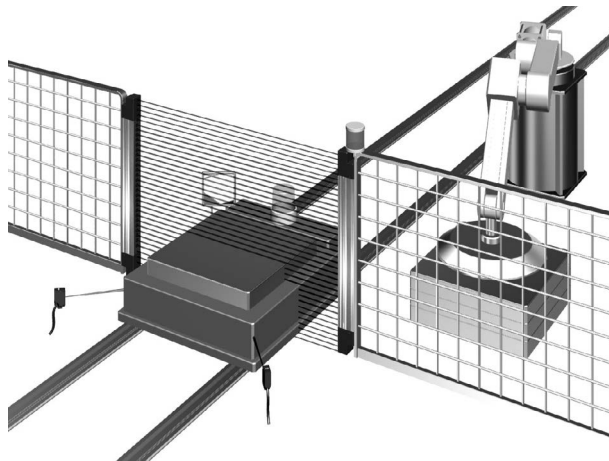

WARNING

The muting and override functions disable the safety functions of the device. You must ensure safety using other method when these functions are operating.



Install muting sensors so that they can distinguish between the object that is being allowed to be passed through the detection zone and a person.

If the muting function is activated by the detection of a person, it may result in serious injury.



All muting lamps that indicate state of muting function must be installed where workers can see them from all the operating positions.



Use 2 independent input devices for muting input. A muting state may occur due to a single failure of the muting sensor.



Muting related time must be properly configured for its application by a sufficiently trained and qualified person, and the person must have responsibility for settings, especially when setting the muting time limit to infinite.



You must install F3SG-RR, muting sensor, and physical barrier, and configure time settings for muting so that an operator should not enter hazardous zone.



The Dynamic Muting function can configure a new muting zone after muting is enabled based on a result of workpiece height measurement for a certain period of time. The function must be used after careful verification by a qualified person with sufficient training. Apply additional safety measures if required.



■ Using muting function

<Muting sensor>

The muting sensor is the sensor to trigger a signal to temporarily disable the safety functions of the F3SG-RR. You can use a photoelectric sensor of through-beam type or reflective type proximity switch, or limit switch. (Recommended: OMRON E3Z series, E2E series (3-wire type), D4N series)

Use a 3-wire type transistor output, which is the same as the output type of the F3SG-RR, or NO contact. Two-wire type sensor must not be used.



When the F3SG-RR is in PNP settings, use the muting sensor of the PNP transistor type.

When the F3SG-RR is in NPN settings, use the muting sensor of the NPN transistor type.

CHECK!

<Muting lamp>

You may need a muting lamp depending on your application or as a result of a risk assessment analysis. Before determining the use of the muting lamp, check laws and regulations of the country or region where the F3SG-RR is used and make sure of full compliance with them. For the muting lamp, use a Lamp (F39-LP and F39-BTLP, sold separately) or a commercially available external indicator. The external indicator can be connected to the auxiliary output.



For settings of the auxiliary output, see 2-11. *Auxiliary Output*.



For settings of the optional Lamp (F39-LP and F39-BTLP, sold separately), see 2-20. *Lamp*

<LED indicator statuses of F3SG-RR: Receiver>

Top-beam-state indicator	Blinks during muting/override.
Bottom-beam-state indicator	
Sequence error indicator	Blinks during a muting sequence error.
Configuration indicator	If the Dynamic Muting function is enabled, the indicator flashes while measuring the workpiece height.
	If the Dynamic Muting function is enabled, the indicator turns on after the new muting zone is reflected.



For muting error indication, see 7-1-2-3. *Muting Sequence Error Indication*.



For dynamic muting, see 2-12-5. *Dynamic Muting*.



For the use in conjunction with other functions, see 2-1. *Combination of Functions*.

<Muting range>

You can specify a detection zone to be muted within the detection zone of the F3SG-RR.

Muting Range	Description
Full Zone Muted State (factory default setting)	Full area of the detection zone is muted. This disables the full detection zone and is used typically.
Partial Zone Muted State	A specified area in the detection zone configured by the Configuration Tool is muted. This can be used if you want to disable only a specific area of the detection zone. Specifying the full zone results in the Full Zone Setting State.
Dynamic Muting	This can be used by enabling the Dynamic Muting function. The full detection zone is disabled for a certain time period from the start of the muting, then a partial zone is muted depending on the detected workpiece size.  2-12-5. Dynamic Muting

2-12-2. Standard Muting Mode

The factory default setting is set to this mode.

Turning muting inputs A and B ON with time difference enables muting state.

■ Start conditions

If both of the following two conditions are satisfied, the muting state is enabled.

1. No interrupting object is found in the F3SG-RR's detection zone, and safety outputs are ON.
2. After muting input A is turned ON*, muting input B is turned ON* within the range between the muting input time limit values T1min (0.1 s) and T1max (4 s).

*PNP setting: Vs-3V to Vs, NPN setting: 0 to 3V

Muting state can be enabled in up to 80ms after the condition No.2 is satisfied.

When the condition No.1 is satisfied but the time requirement of the condition No.2 is not, a muting sequence error occurs and the Sequence error indicator on the receiver blinks. However, when there is a muting sequence error, the F3SG-RR does not enter the Muting state but it continues the normal operation with the safety function enabled.

 For muting error indication, see 7-1-2-3. *Muting Sequence Error Indication*.

Muting error can be released by any of following conditions:

1. Correct muting initial condition continues for 0.1 s or longer. *
2. Power cycle when muting inputs A and B are in the OFF state.

* The correct initial muting condition is the state where the following two conditions are satisfied.

- Safety outputs of the F3SG-RR are turned ON.
- Muting input A and B are turned OFF.

■ End conditions

If either of the following conditions is satisfied, the muting state is released.

- Muting input A or B turns OFF for the maximum allowable muting signal interruption of T3 (at least 0.1 s: configurable) or longer.
- The duration of the muting state exceeds the muting time limit of T2 (at least 60 s: configurable).

 Muting state is also released when the F3SG-RR enters the Lockout state.
CHECK!

■ Timing chart

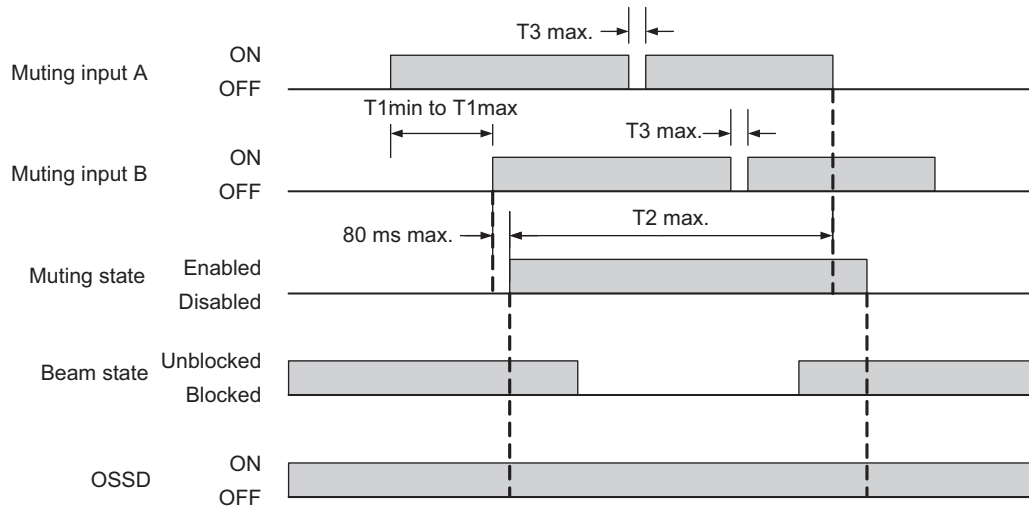

T1min: Muting input time limit value (minimum)
 T1max: Muting input time limit value (maximum)
 T2: Muting time limit
 T3: Maximum allowable muting signal interruption

■ Factory default setting

Variable	Variable name	Value	Description
T1min	Muting input time limit value (minimum)	0.1 s	Minimum time difference between muting inputs A and B. If the time difference between muting inputs A and B is smaller than this value, a muting sequence error occurs.
T1max	Muting input time limit value (maximum)	4 s	Maximum time difference between muting inputs A and B. If the time difference between muting inputs A and B is larger than this value, a muting sequence error occurs.
T2	Muting time limit	60 s	The duration time of the Muting function. The Muting state is cancelled if it continues for longer than this time limit.
T3	Maximum allowable muting signal interruption	0.1 s	Maximum duration of a signal interruption allowed in muting inputs A and B.

■ Basic wiring diagram

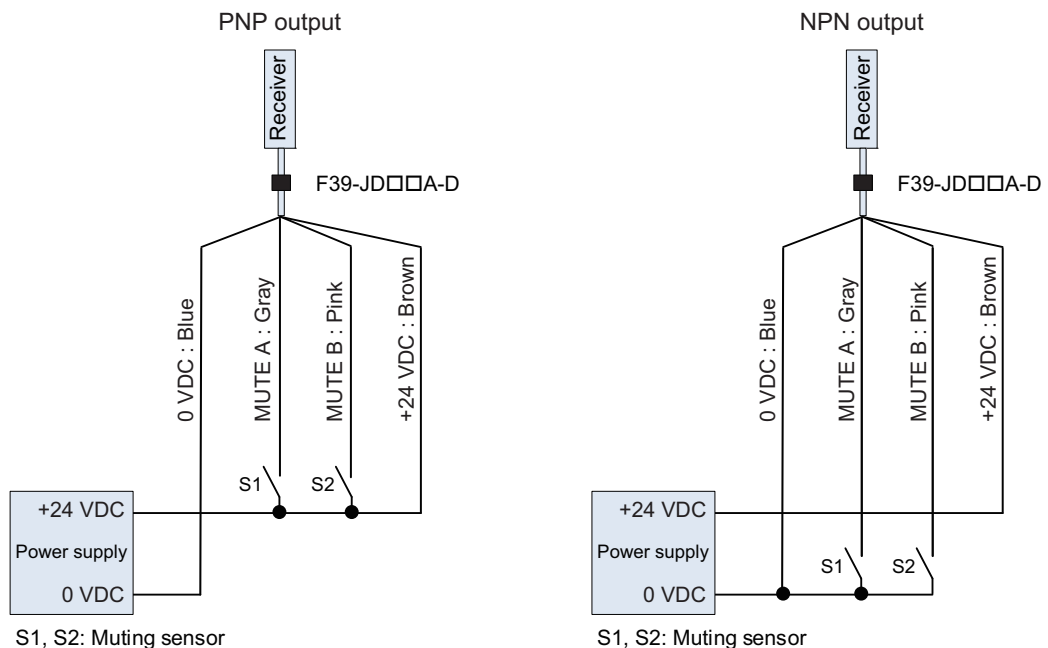

■ Installation standard for muting sensors

- Set the muting sensors so that they can detect all of the passing detection (palettes, automobiles, etc.). Do not install the muting sensor in a position so that only the front or rear end of the objects is detected.
- Set the muting sensors so that they detect the objects even when they are loaded on palettes or other transport devices.
- Also, install the F3SG-RR and muting sensors so that each object passes through all muting sensors before the next object arrives at the first muting sensor. Also, install all F3SG-RRs and muting sensors so that no person is able to accidentally enter the hazardous zone while the muting function is enabled.
- If objects' speeds can vary, the allocation of muting sensors must be taken into consideration.
- Install muting sensors so that they can distinguish between the object that is being allowed to be passed through the detection zone and a person.

■ Installation example 1 of standard muting mode (Using two muting sensors)

This is an example of two retro-reflective type photoelectric sensors used as muting sensors installed in a cross pattern.

Use two sensors when the length L of the workpieces are not constant or are insufficient.

1. Before a workpiece passes through

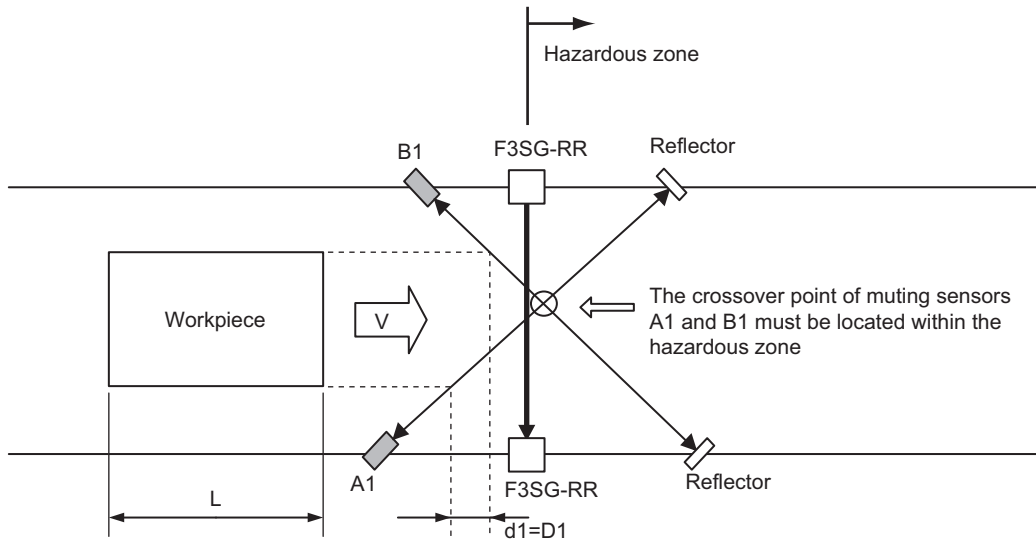

L: Length of workpiece
 d1: Maximum distance required for the muting sensor to keep the muting function enabled
 D1: Minimum distance required for the muting sensor to keep the muting function enabled

The output state of muting sensors A1 and B1 are both OFF, and the safety function of the F3SG-RR is working.

In this example where two muting sensors are used, the crossover point of muting sensors A1 and B1 is in the hazardous zone. This configuration prevents the muting function from being enabled by a person passing through the crossover point.

2. Muting state started

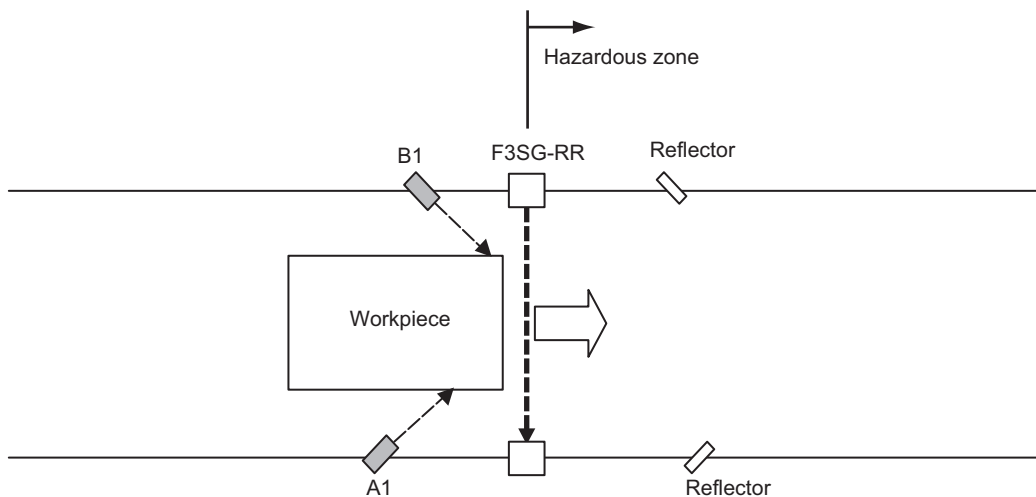

When muting sensors A1 and B1 are turned ON in this order, the F3SG-RR enters the muting state. In this state, the safety function of F3SG-RR is disabled.

3. Muting state is maintained

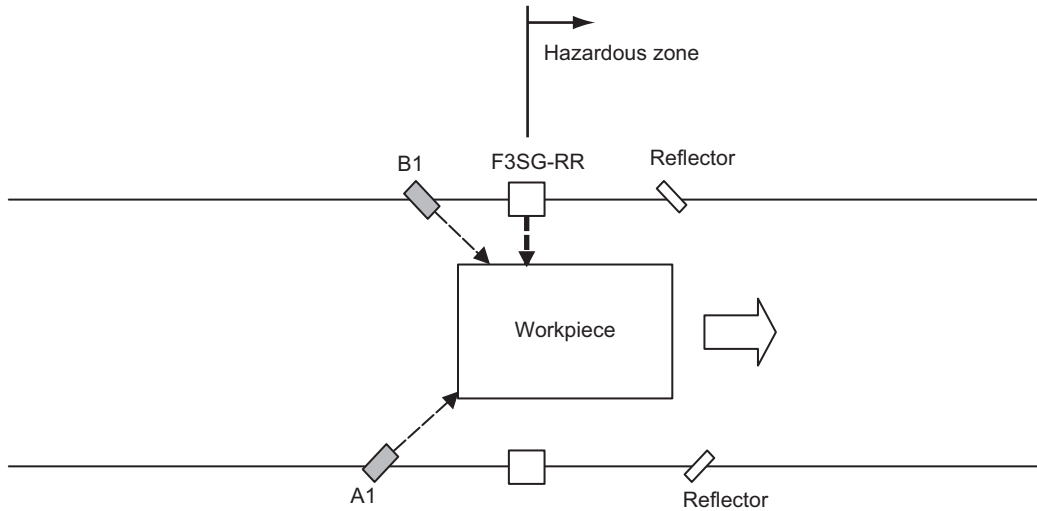

The F3SG-RR is blocked but the safety function is disabled due to the muting state, and safety outputs 1 and 2 are turned ON.

4. The muting state is released

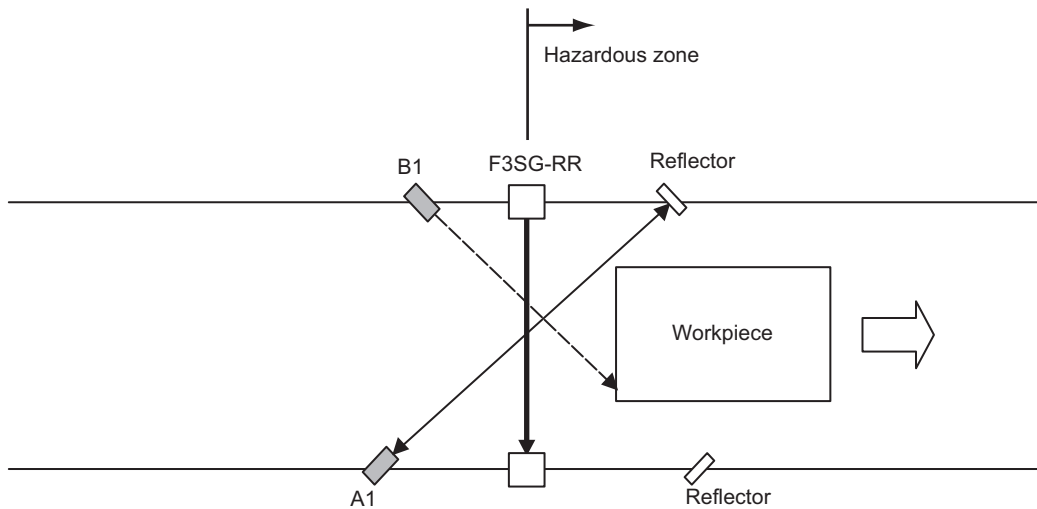

Muting sensor A1 is turned OFF, the muting state is released, and the safety function of the F3SG-RR is enabled.

<Installation distance>

The minimum distance, D1 [m], required for muting sensors to keep the muting state enabled is :

$$D1 < L \dots \dots \text{Formula (1)}$$

L [m]: Length of a workpiece

The maximum distance, d1 [m], required for muting sensors to keep the muting state enabled is :

$$V \times T1_{\min} < d1 < V \times T1_{\max} \dots \dots \text{Formula (2)}$$

V [m/s]: Approach speed of a workpiece

T1min [s]: Muting input time limit value (minimum). It is set as 0.1 s.

T1max [s]: Muting input time limit value (maximum). It is set as 4 s.

To enable the muting state, D1 and d1 must satisfy formulas (1) and (2), respectively.

This distance must prevent the muting state from being enabled by a person passing through the muting sensors.

Also, install the F3SG-RR and muting sensors so that each workpiece passes through all muting sensors before the next workpiece arrives at the first muting sensor (PNP mode).

<Wiring diagram (PNP setting)>

Using a photoelectric switch as a muting sensor

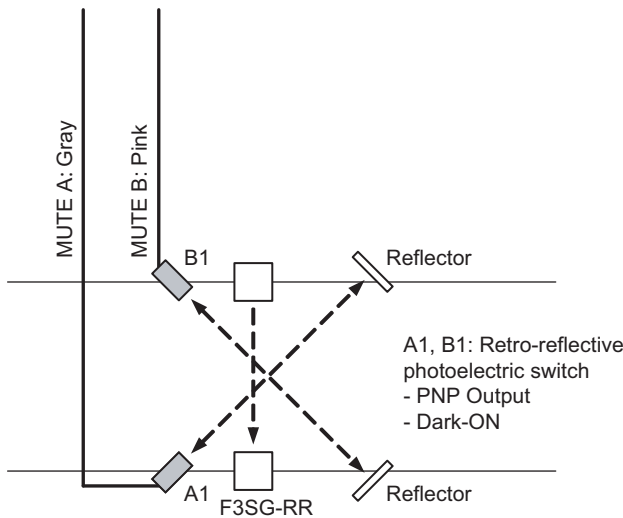

Using an NO contact type switch as a muting sensor

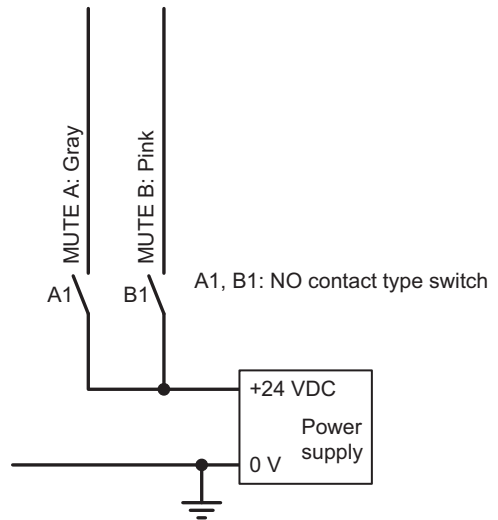

Note. Two-wire type muting sensor cannot be used.

<Timing chart>

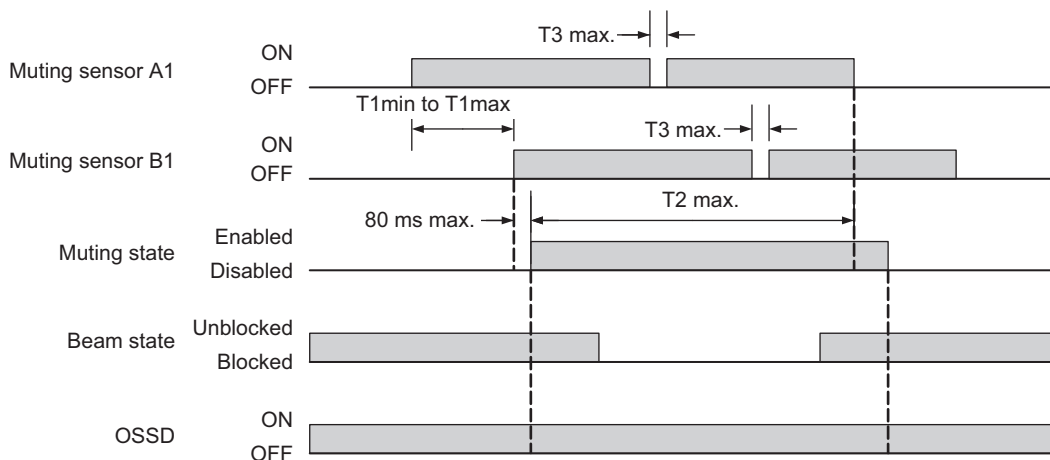

T1min: Muting input time limit value (minimum)
 T1max: Muting input time limit value (maximum)
 T2: Muting time limit
 T3: Maximum allowable muting signal interruption

■ Installation example 2 of standard muting mode (Using four muting sensors)

This installation example uses four through-beam type photoelectric sensors as muting sensors. The use of four muting sensors is useful when the length of the workpieces is constant or longer, and the entrance and exit have enough space. Muting can be performed from both directions in the arrangement as shown below.

1. Before a workpiece passes through

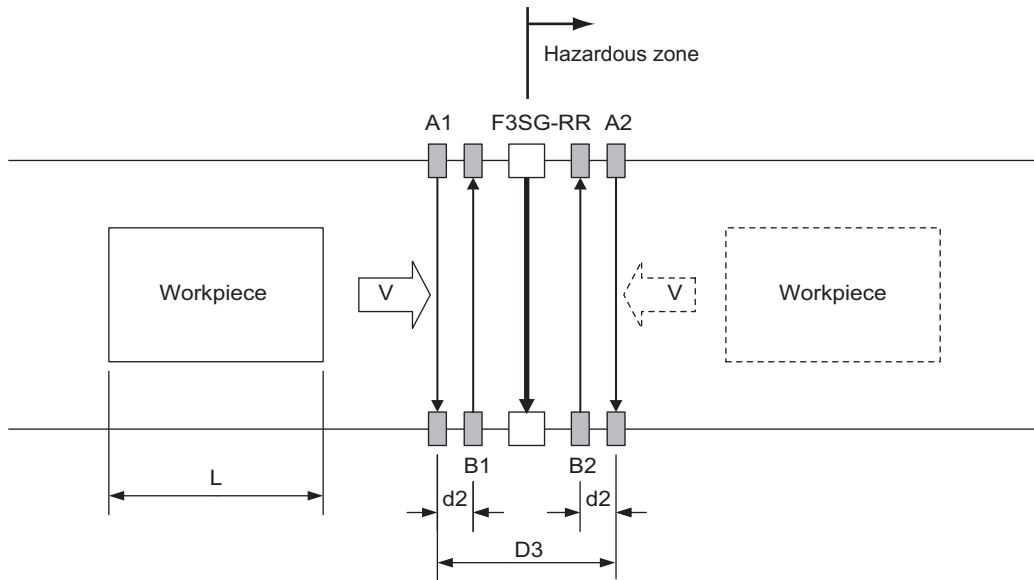

L: Length of workpiece
 d2: Maximum distances required for the muting sensor to keep the muting function enabled
 D3: Minimum distance required for the muting sensor to keep the muting function enabled

All muting sensors are turned OFF and the safety function of the F3SG-RR is working.

2. The muting sensor is blocked and the safety function of the F3SG-RR is disabled

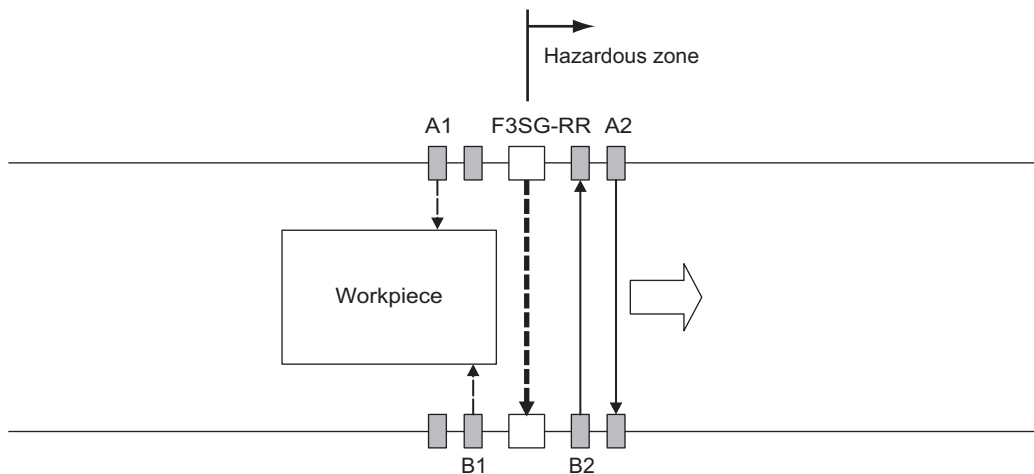

When muting sensors A1 and B1 are turned ON in this order, the muting state is enabled. In this state, the safety function of F3SG-RR is disabled.

3. The muting sensor is blocked and the safety function of the F3SG-RR is disabled

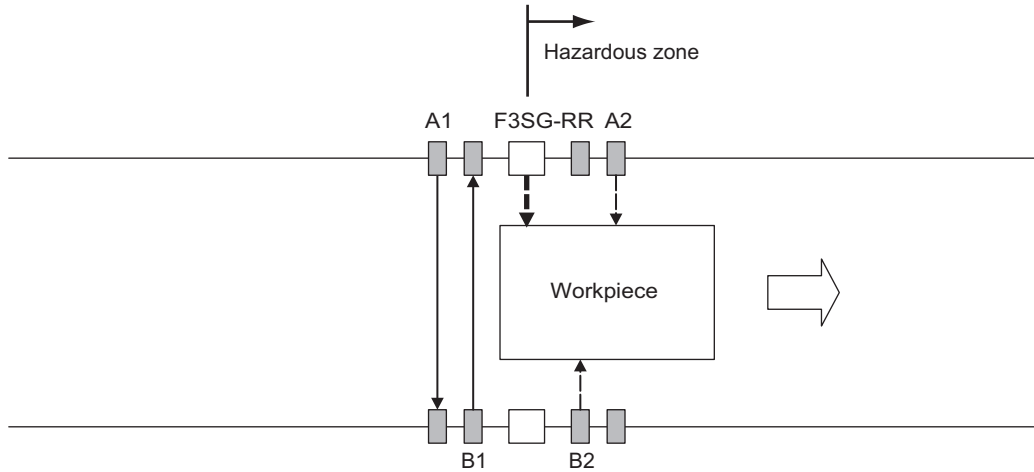

Muting sensors A1 and B1 are turned OFF but A2 and B2 are ON, so the muting state is still maintained. Safety outputs 1 and 2 are turned ON.

4. The muting state is released

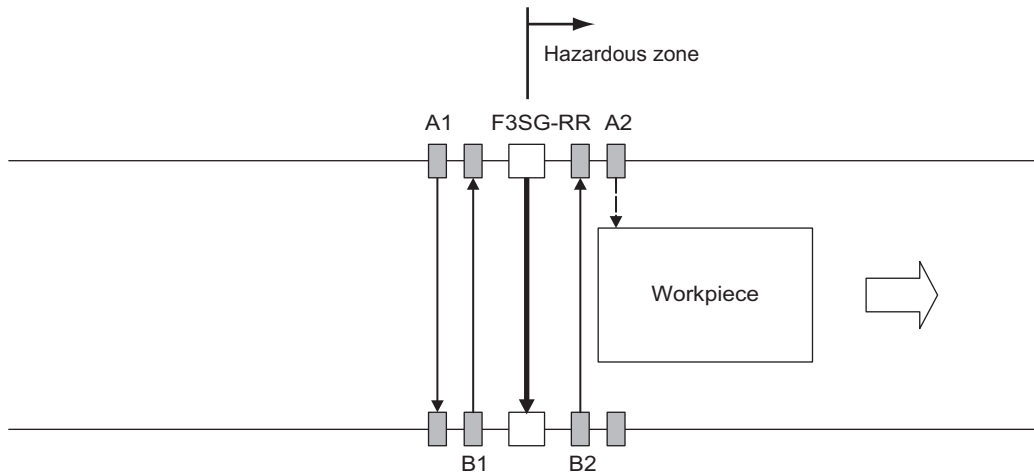

Muting sensor B2 is turned OFF, the muting state is released, and the safety function of the F3SG-RR is enabled.

<Installation distance>

The minimum distance, D3 [m], required for muting sensors to keep the muting state enabled is :

$$D3 < L \dots \dots \text{Formula (3)}$$

L [m]: Length of a workpiece

The maximum distance, d2 [m], required for muting sensors to keep the muting state enabled is :

$$V \times T1_{\min} < d2 < V \times T1_{\max} \dots \dots \text{Formula (4)}$$

V [m/s] : Approach speed of a workpiece

T1_{min} [s] : Muting input time limit value (minimum). It is set as 0.1 s. (configurable)

T1_{max} [s] : Muting input time limit value (maximum). It is set as 4 s. (configurable)

To enable the muting state, D3 and d2 must satisfy formulas (3) and (4), respectively. This distance must prevent the muting state from being enabled by a person passing through the muting sensors. Also, install the F3SG-RR and muting sensors so that each workpiece passes through all muting sensors before the next workpiece arrives at the first muting sensor.

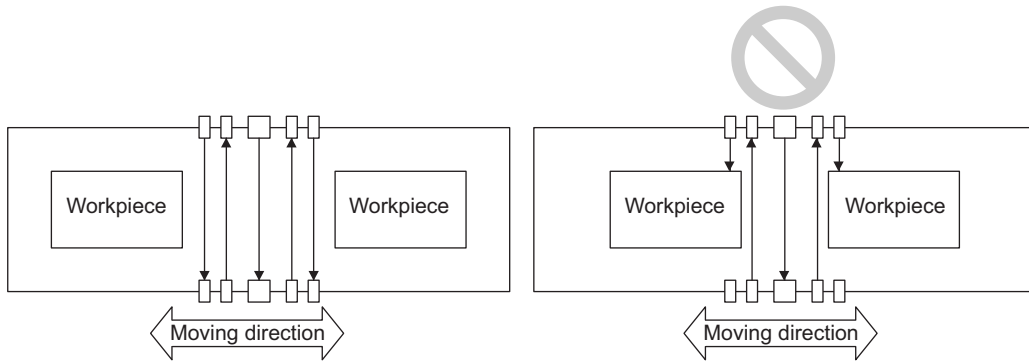

<Wiring diagram (PNP setting)>

Using a photoelectric switch as a muting sensor

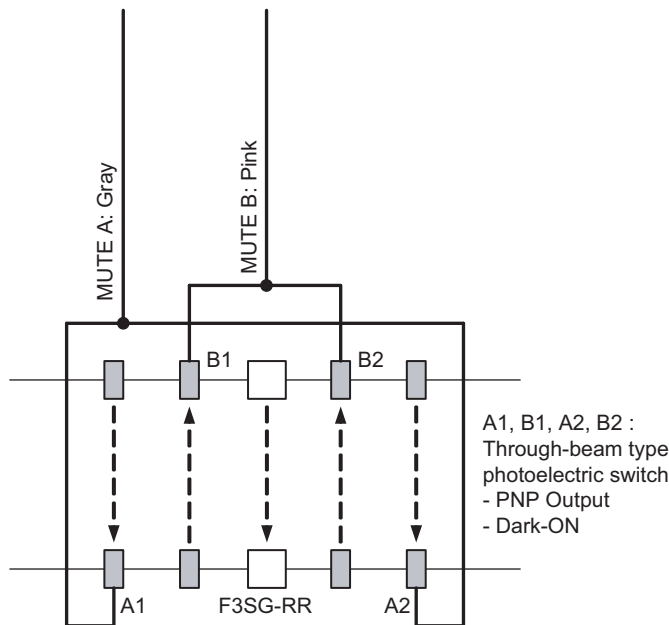

Using an NO contact type switch as a muting sensor (PNP mode)

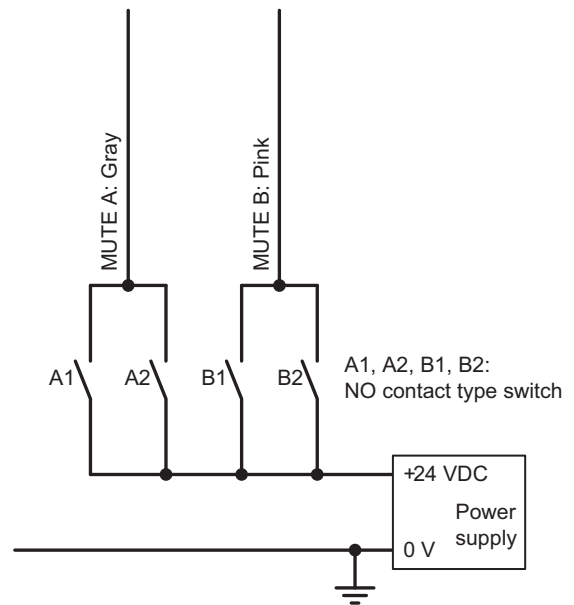

Note. Two-wire type muting sensor cannot be used.

<Timing chart>

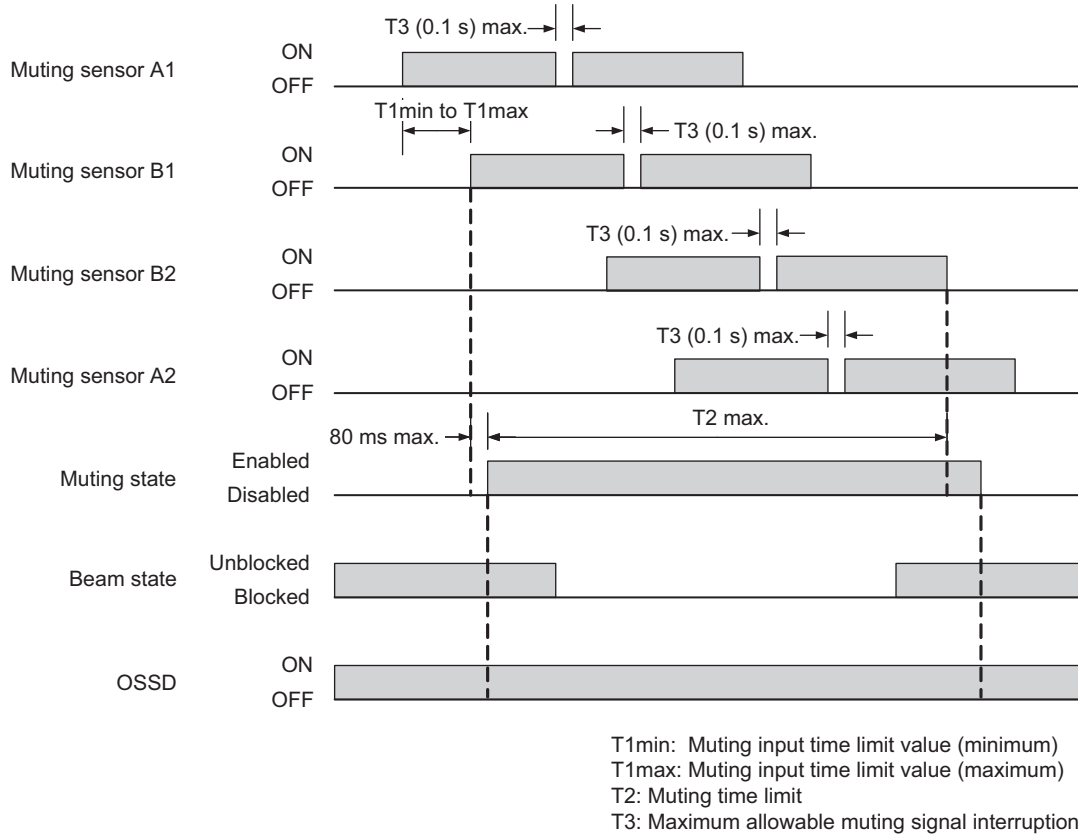

<Reference: Preventing light interference of muting sensor>

When a photoelectric sensor is used as a muting sensor, light interference may cause a muting error of F3SG-RR.

The cause and measures for light interference are shown as follows:

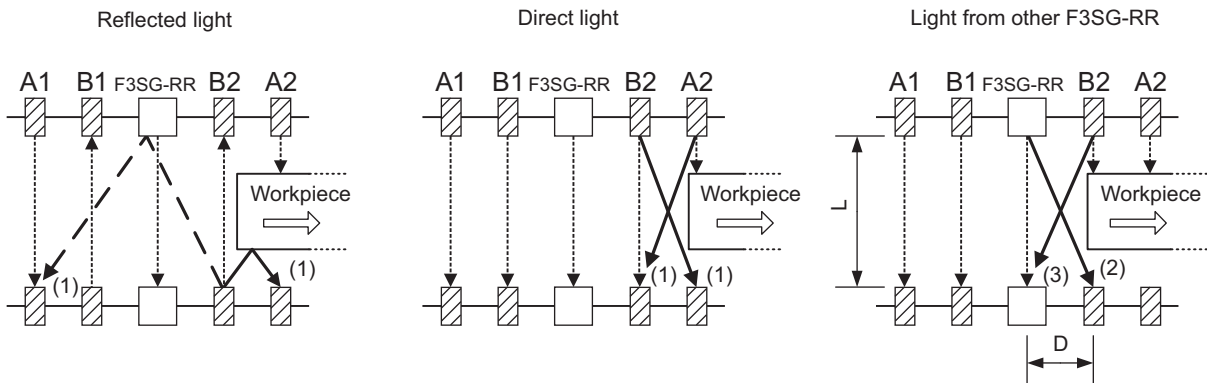

(1) Interference between muting sensors

- Use sensors with mutual interference prevention (such as retro-reflective E3Z-R□□ series)
- Use laser-type sensors (such as laser-type E3Z-LR□ series)
- Take distance from a sensor causing the interference
- Displace beams for each other to prevent interference (change installation height or place them crosswise)
- Install a physical barrier
- Attach interference prevention filter (provided for E3Z series as accessories)
- Attach a slit to reduce light intensity (provided for E3Z series as accessories)
- Lower the sensitivity
- Reduce a distance between a workpiece and a muting sensor to prevent reflected light from a workpiece

(2) Interference to a muting sensor from F3SG-RR

- Take distance (D) from a sensor causing the interference
- Displace beams for each other to prevent interference (change installation height or place them crosswise)
- Install a physical barrier
- Arrange sensors in alternation
- Lower the sensitivity

(3) Interference to F3SG-RR from a muting sensor

- Use a red LED type sensor (such as retro-reflective E3Z-R□□ series)
- Use laser-type sensors (such as laser-type E3Z-LR□ series)
- Take distance (D) from a sensor causing the interference
- Displace beams for each other to prevent interference (change installation height or place them crosswise)
- Install a physical barrier
- Arrange sensors in alternation
- Attach a slit to reduce light intensity (provided for E3Z series as accessories)

Mutual interference between a muting sensor and F3SG-RR in (2) and (3) above can be prevented by configuring D satisfying a formula shown below:

- If $L = 0.3$ to 3 m, $D = 0.26$ m or larger
- If $L = 3$ m or larger, $D = L \times \tan 5^\circ = L \times 0.088$ m or larger

L : Distance between an emitter and a receiver of the F3SG-RR

D : Distance between a muting sensor and a F3SG-RR

2-12-3. Exit-Only Muting Mode

Turning muting inputs A and B ON with time difference enables muting state. Difference from standard mode exists in muting completion condition.

■ Start conditions

If both of the following 2 conditions are satisfied, the muting state is enabled.

1. No interrupting object is found in the F3SG-RR's detection zone, and the safety outputs are ON.
2. After muting input A is turned ON*, muting input B is turned ON* within the range between the muting input time limit values T1min (0.1 s) and T1max (4 s).

*PNP setting: Vs-3V to Vs, NPN setting: 0 to 3V

Muting state can be enabled in up to 80 ms after the condition No.2 is satisfied.

If the condition No.1 is satisfied but the time requirement of the condition No.2 is not, a muting error occurs, and the Sequence error indicator on the receiver turns ON. However, when there is a muting error, the F3SG-RR continues the normal operation with the safety function enabled.

 For muting error indication, see 7-1-2-3. *Muting Sequence Error Indication*.

Muting error can be released by any of following conditions:

1. Correct muting initial condition continues for 0.1 s or longer. *
2. Power cycle when the muting inputs A and B are in the OFF state.

* The correct initial muting condition is the state where the following two conditions are satisfied.

- Safety outputs of the F3SG-RR are turned ON.
- Muting input A and B are turned OFF.

■ End conditions

If any of the following condition is satisfied, the muting state is released.

- When a workpiece passes a muting sensor A or B and the exit-only muting delay time (4 s) passes.
- When a workpiece passes F3SG-RR's detection zone and the muting end wait time (1 s: configurable) passes.
- The duration of the muting state exceeds the muting time limit (60 s: configurable).



Muting state is also released when the F3SG-RR enters the Lockout state.

■ Timing chart

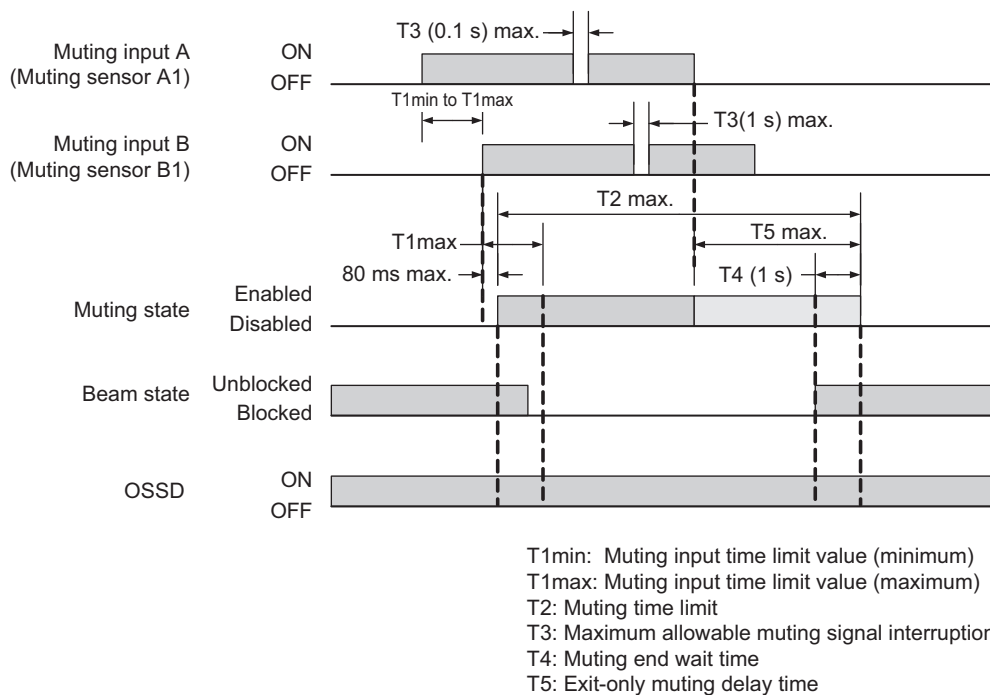

Note. This timing chart shows the case in which the muting state was released under the condition of T4 (1 s).

■ Factory default setting

Variable	Variable name	Value	Description
T1min	Muting input time limit value (minimum)	0.1 s	Minimum time difference between muting inputs A and B. If the time difference between muting inputs A and B is smaller than this value, a muting sequence error occurs.
T1max	Muting input time limit value (maximum)	4 s	Maximum time difference between muting inputs A and B. If the time difference between muting inputs A and B is larger than this value, a muting sequence error occurs.
T2	Muting time limit	60 s	The duration time of the Muting function. The Muting state is cancelled if it continues for longer than this time limit.
T3	Maximum allowable muting signal interruption	0.1 s	Maximum duration of a signal interruption allowed in muting inputs A and B.
T4	Muting end wait time	1 s	Time difference from when the F3SG-RR is unblocked until the Muting state is cancelled.
T5	Exit-only muting delay time	4 s	Time difference from when the signal of Muting input A or B is turned OFF until the Muting state is cancelled.



Muting state is also released when the F3SG-RR enters the Lockout state.

■ Basic wiring diagram

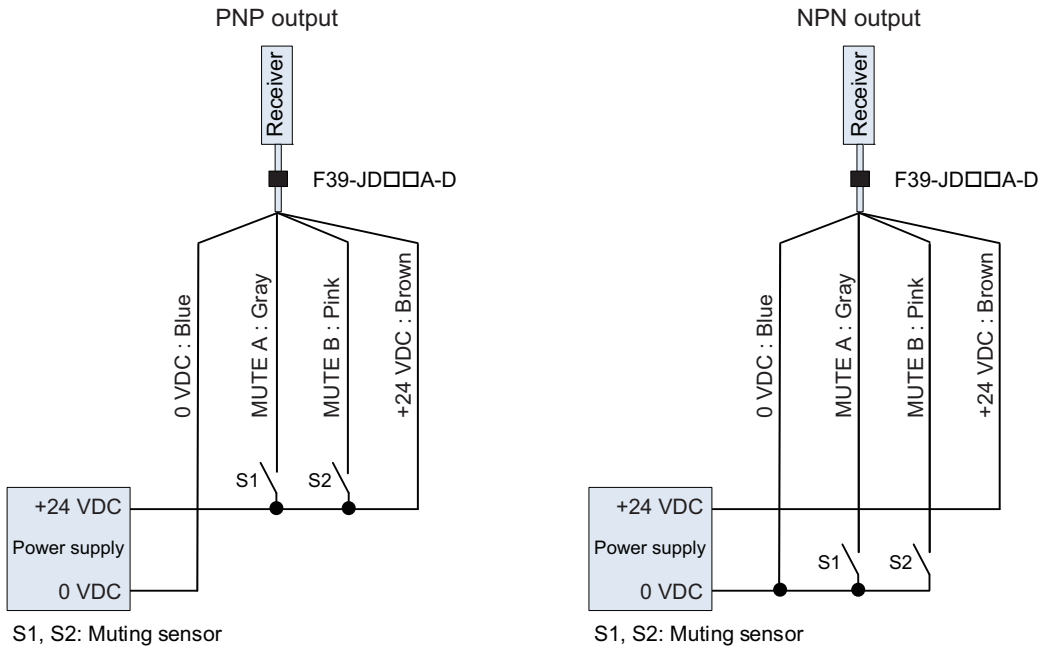

■ Installation example of Exit-Only Muting Mode

This is an installation example of exit-only muting mode. When exit-only muting mode is set, install the muting sensor on the hazardous side of the workpiece exit.

This can be used if a workpiece has a certain length and the hazardous side of the workpiece exit has enough space around it.

1. Before a workpiece passes through

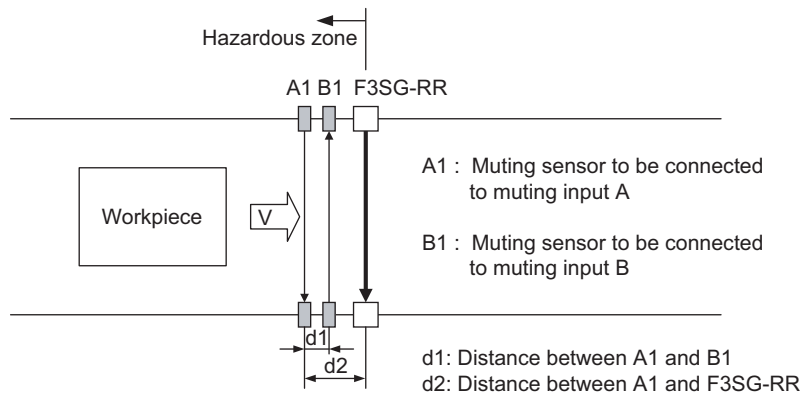

All muting sensors are turned OFF and the safety function of the F3SG-RR is working.

2. The muting sensor is blocked and the safety function of the F3SG-RR is disabled

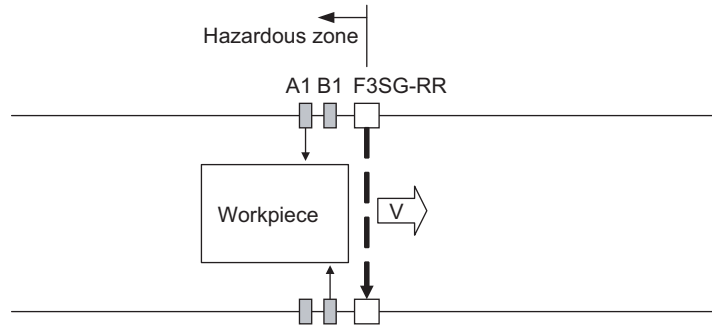

When muting sensors A1 and B1 are turned ON in this order, and the muting state is enabled. In this state, the safety function of F3SG-RR is disabled.

3. Muting sensor A1 is turned OFF

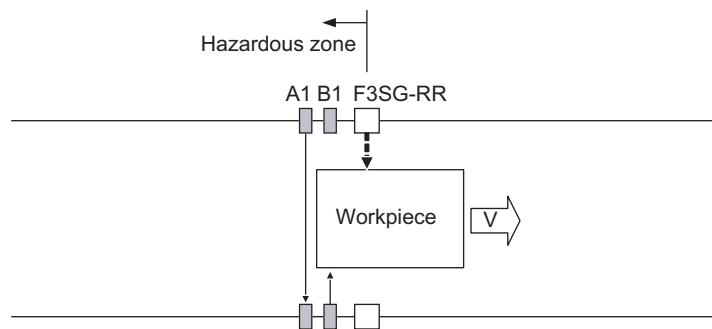

The workpiece has completely passed the muting sensor A1 and the sensor is now in the OFF state. For standard muting system, muting is released here. For exit-only muting, F3SG-RR's safety function is disabled for the exit-only muting delay time: T5.

4. Muting sensor B1 is turned OFF

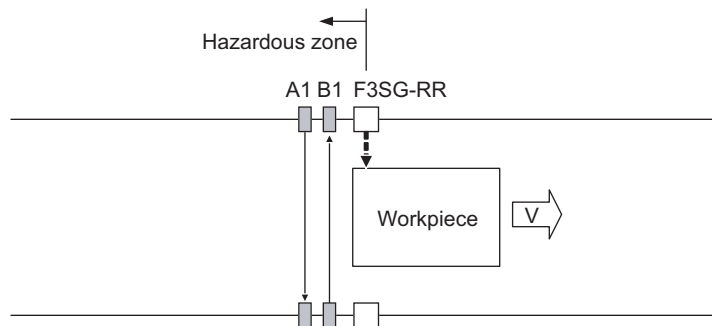

The workpiece has completely passed the muting sensor B1 and the sensor is turned OFF. F3SG-RR disables its safety function if it is within the exit-only muting delay time.

5. The workpiece passed F3SG-RR's detection zone

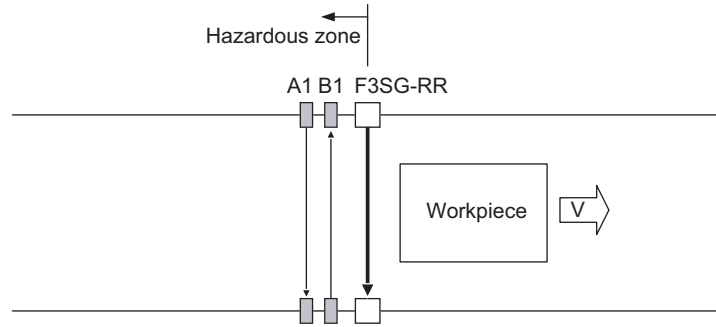

A workpiece has passed F3SG-RR's detection zone. When the muting end wait time: T4 (1 s: configurable) passes after the F3SG-RR is unblocked, the muting state is released.

<Installation Distance>

Distances between muting sensors A1, B1, and F3SG-RR must be configured based on speed of a workpiece.

Distance d1 between muting sensors A1 and B1 must satisfy Equations (1) and (2).

Distance d2 between muting sensor A1 and F3SG-RR must satisfy Equations (3) and (4).

Time t1 [s] to turn muting sensors A1 and B1 in this order is:

$$t1 = d1 / V \dots\dots\dots \text{Equation (1)} \quad d1 [m] : \text{Distance between muting sensors A1 and B1}$$

$$V [m/s] : \text{Approach speed of a workpiece}$$

Time t1 in Equation (1) for F3SG-RR to enter muting state is within a range shown below:

$$T1_{min} < t1 < T1_{max} \dots \text{Equation (2)} \quad T1_{min} [s] : \text{Muting input time limit value (minimum)}$$

$$T1_{max} [s] : \text{Muting input time limit value (maximum)}$$

 The values of T1_{min} and T1_{max} can be changed by the Configuration Tool.

CHECK!

Time t2 [s] for a workpiece to pass F3SG-RR's detection zone after passing the muting sensor A1 is:

$$t2 = d2 / V \dots\dots\dots \text{Equation (3)} \quad d2 [m] : \text{Distance between muting sensor A1 and F3SG-RR}$$

$$V [m/s] : \text{Approach speed of a workpiece}$$

Time t2 in Equation (3) must satisfy following condition:

$$t2 < T5 \dots\dots\dots \text{Equation (4)} \quad T5: \text{Exit-only muting delay time}$$

 The value of T5 can be changed by the Configuration Tool.

CHECK!

Sensors must be installed so that person's passing should not cause muting state.

Also, muting sensors and F3SG-RR must be installed so that muting state caused by a workpiece should be ended before the next workpiece arrives at the first muting sensor.

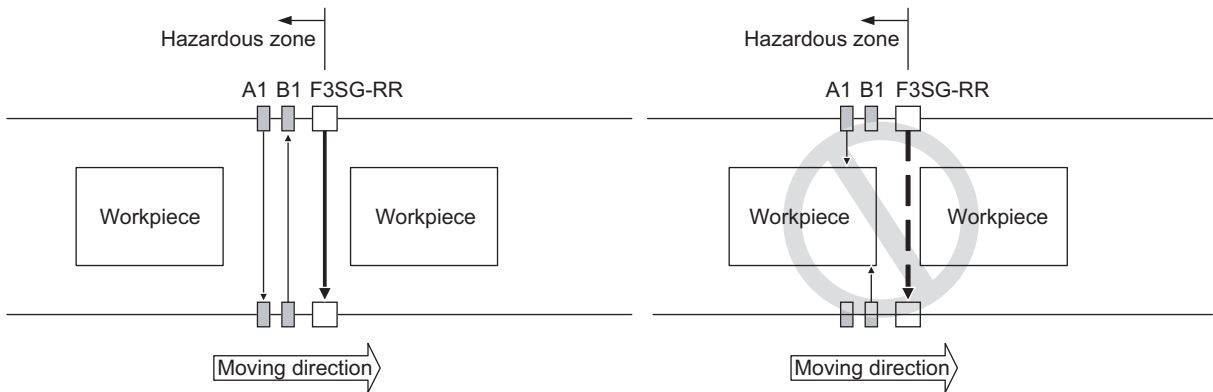

<Timing Chart>

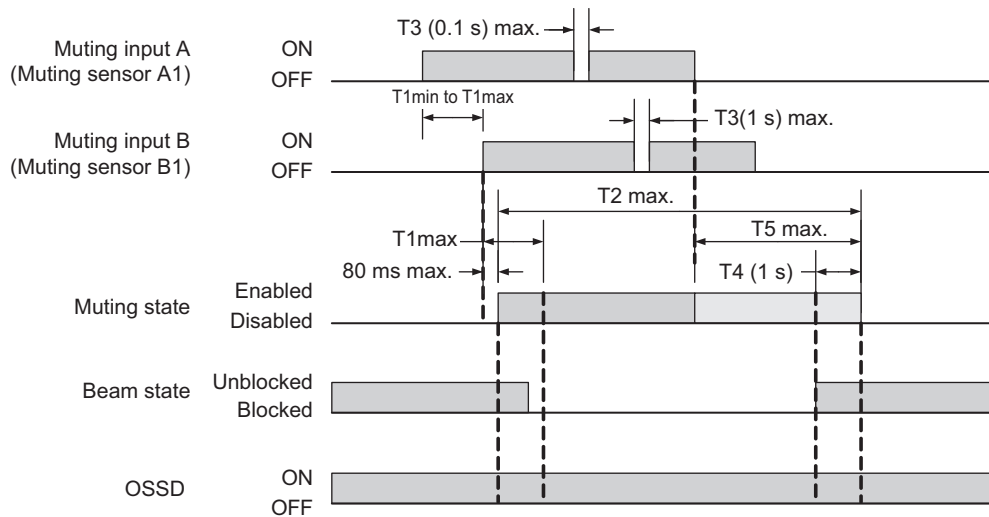

T1min: Muting input time limit value (minimum)
 T1max: Muting input time limit value (maximum)
 T2: Muting time limit
 T3: Maximum allowable muting signal interruption
 T4: Muting end wait time
 T5: Exit-only muting delay time

2-12-4. Position Detection Muting Mode

Muting state is enabled when muting input A turns ON from the OFF state and muting input B turns OFF from the ON state within the muting input time limit value $T1_{max}$, measured by a limit switch, etc. Muting inputs must be heterogeneous redundant inputs such as the combination of NO contact and NC contact types. (When using photoelectric sensors of PNP output, use one for Light-ON operation while the other for Dark-ON.) This mode can be used for such a case that the F3SG-RR should be temporarily disabled while a worker puts objects at a loading station.



When using the combination of NO and NC contacts for the muting inputs, use an NO contact for muting input A and an NC contact for muting input B. When using photoelectric sensors of PNP output for the muting inputs, set one for muting input A to Dark-ON and the other for muting input B to Light-ON.

■ Start conditions

If both of the following 2 conditions are satisfied, the muting state is enabled.

1. No interrupting object is found in the F3SG-RR's detection zone, and the safety outputs are ON.
2. The duration between when the muting input A is turned ON* from the OFF state and when the muting input B is turned OFF from the ON state* is within the range between the muting input time limit values $T1_{min}$ (0.1 s) and $T1_{max}$ (4 s). Order of muting inputs A and B is irrelevant.

*PNP setting: V_s-3V to V_s , NPN setting: 0 to 3V

Muting state can be enabled in up to 80 ms after the condition No. 2 is satisfied.

If the condition No. 1 is satisfied but the time requirement of the condition No.2 is not, a muting error occurs, and the Sequence error indicator on the receiver turns ON. However, when there is a muting error, the F3SG-RR continues the normal operation with the safety function enabled.



For muting error indication, see 7-1-2-3. *Muting Sequence Error Indication*.

Muting error can be released by any of following conditions:

1. Correct muting initial condition continues for 0.1 s or longer. *1
2. Power cycle when the muting inputs A and B are in the OFF state.

*1 The correct initial muting condition is the state where the following two conditions are satisfied.

- Safety outputs of the F3SG-RR are turned ON.
- Muting input A is turned OFF and Muting input B is turned ON.

■ End conditions

If any of the following conditions is satisfied, the muting state is released.

- Muting input A is in the OFF state for $T3$ or longer (0.1 s or longer).
- Muting input B is in the ON state for $T3$ or longer (0.1 s or longer).
- The duration of the muting state exceeds the muting time limit of $T2$ (60 s).



Muting state is also released when the F3SG-RR enters the Lockout state.

CHECK!

■ Timing chart

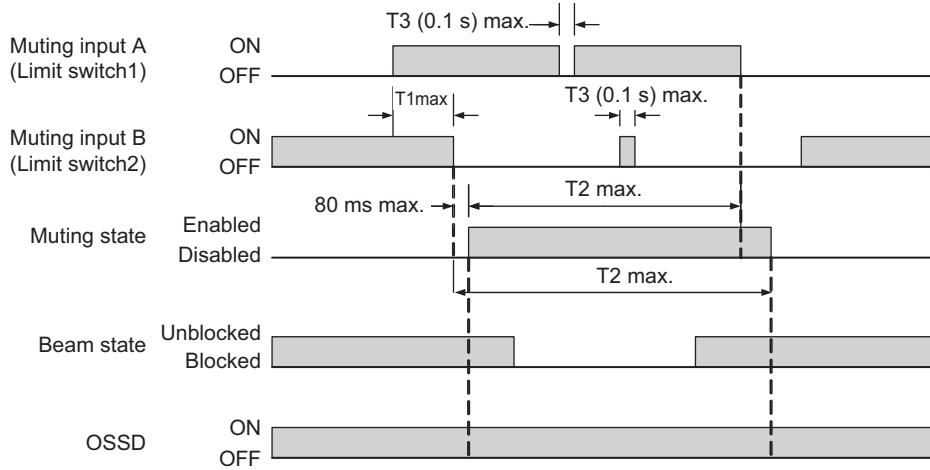

T1max: Muting input time limit value (maximum)
 T2: Muting time limit
 T3: Maximum allowable muting signal interruption

Variable	Variable name	Value	Description
T1max	Muting input time limit value (maximum)	3 s	Maximum time difference between muting inputs A and B. If the time difference between muting inputs A and B is larger than this value, a muting error occurs.
T2	Muting time limit	60 s	The duration time of the Muting function. The Muting state is cancelled if it continues for longer than this time limit.
T3	Maximum allowable muting signal interruption	0.1 s	Maximum duration of a signal interruption allowed in muting inputs A and B.

■ Basic wiring diagram

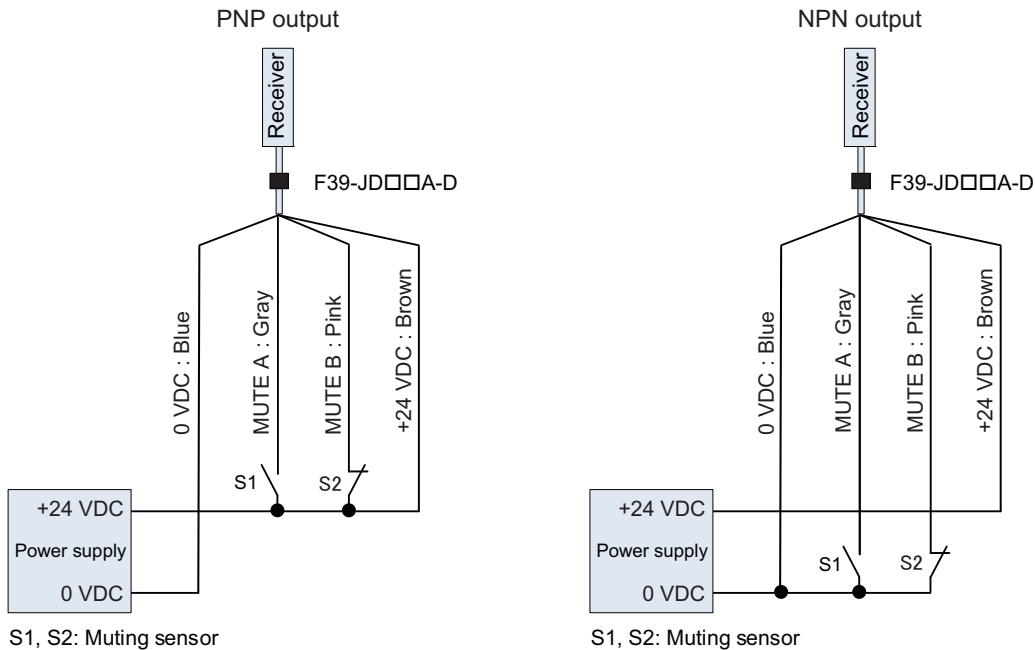

S1, S2: Muting sensor

S1, S2: Muting sensor

■ Installation example of Position Detection Muting Mode

Shown below is an installation example of position detection muting mode.

This is an application that places a workpiece on a machine's turntable surrounded by guard fence. When hazardous part of the machine is on the opposite side of a human body, safety function of F3SG-RR can be disabled so that an operator should be able to place a workpiece on the turntable.

1. Hazardous part of the machine is on the same side of a human body

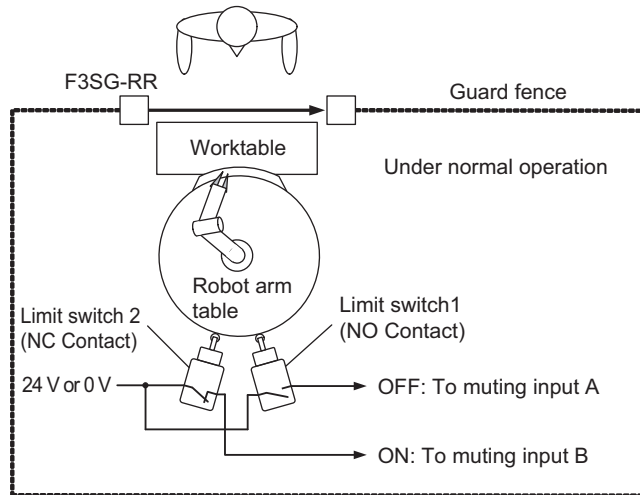

The safety functions of the F3SG-RR is activated with the limit switch 1 (NO contact) being in the OFF state and the limit switch 2 (NC contact) in the ON state.

2. Hazardous part of the machine is on the opposite side of a human body

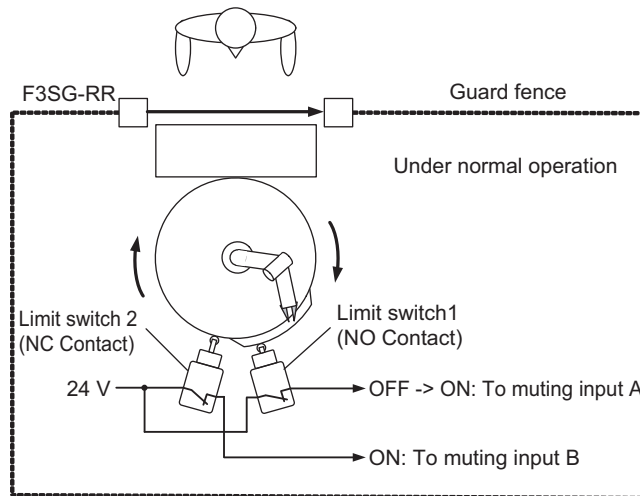

Rotation of a robot arm sets the muting input A from OFF to ON. Safety function of F3SG-RR is enabled.

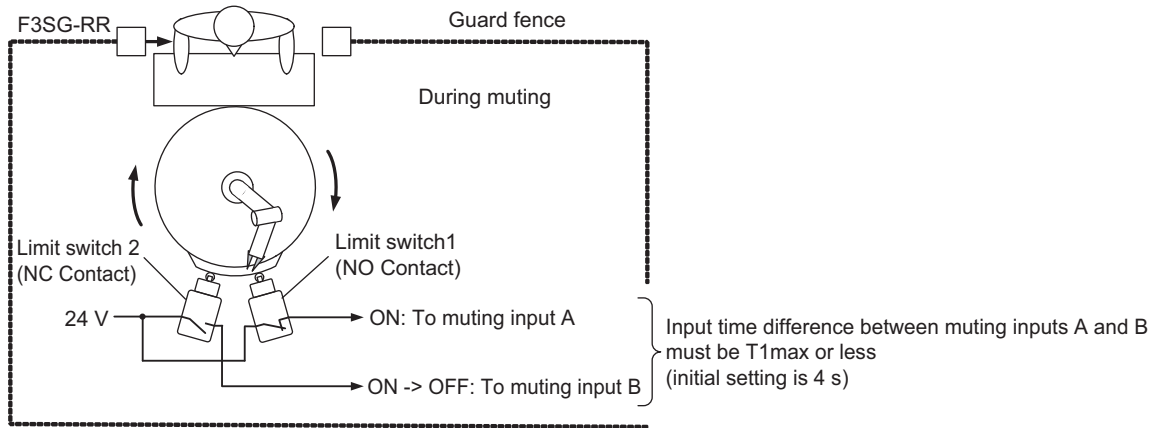

If the duration between when the muting input A is turned ON from the OFF state and when the muting input B is turned OFF from the ON state is within $T1_{max}$ [s], the safety function of the F3SG-RR is disabled.

Time $t1$ [s] for F3SG-RR to enter muting state is within the range shown below:

$$t1 < T1_{max} \dots \dots \dots \text{Equation (5)} \quad T1_{max} \text{ [s] : Muting input time limit value (maximum)}$$

 The value of $T1_{max}$ can be changed by the Configuration Tool.
CHECK!

■ Timing chart

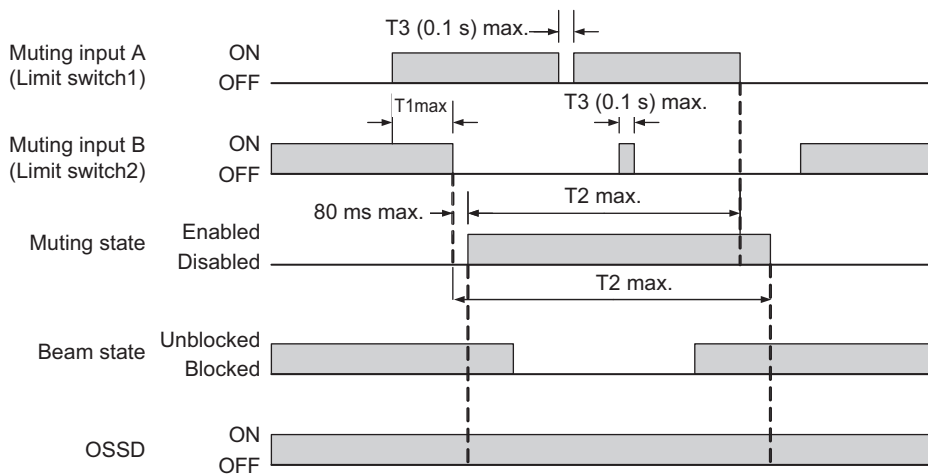

T1max: Muting input time limit value (maximum)
T2: Muting time limit
T3: Maximum allowable muting signal interruption

2-12-5. Dynamic Muting

The Dynamic Muting function can configure a new muting zone while the muting state is enabled, based on a result measuring a workpiece height for a certain period of time.

This materializes safer muting function with a limited muting zone adjusted according to a workpiece height.

■ Usage example

This function cannot be used for an application in which a workpiece height gets larger after measuring the zone as shown below.

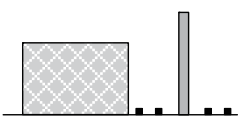
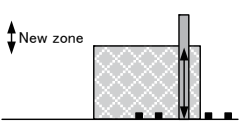
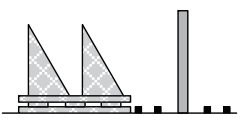
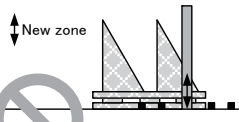
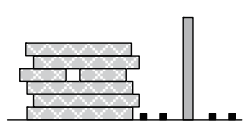
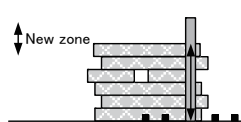
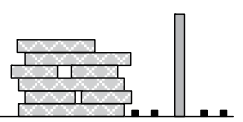
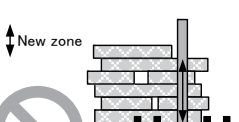
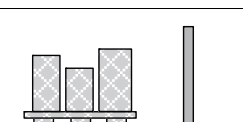
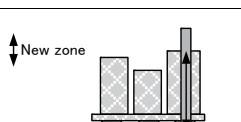
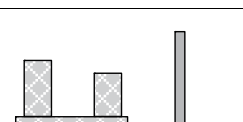
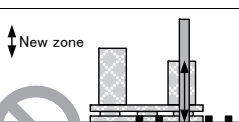
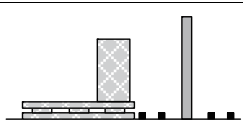
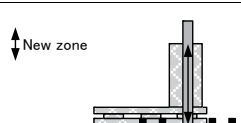
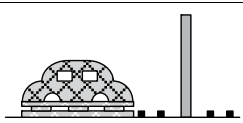
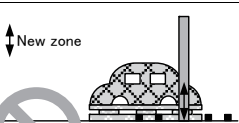
Applicable Example		NOT Applicable Example	
Application Examples	Position after Zone Measurement	Application Examples	Position after Zone Measurement
			
			
			
			

■ Zone measurement start condition

After the muting start condition is satisfied and the full detection zone is muted, interruption of a part of the F3SG-RR causes the Zone Measurement to start.

■ Zone measurement

The Zone Measurement monitors the highest and lowest parts of a passing workpiece during the dynamic muting measurement time T_{dyn} (3 s). (Void spaces in workpiece(s) are ignored.)

■ Zone determination

A zone enclosed by the highest and the lowest parts of the workpiece is set as a new muting zone.

Configuring a dynamic muting allowable beam allows the muting zone to be expanded by the number of allowable beams. Configuring a dynamic muting allowable beam prevents unintended line stop due to swing of a workpiece, etc. (The factory default setting of the dynamic muting allowable beam is 1.)

■ Dynamic muting allowable beam

The dynamic muting allowable beam allows the muting zone measured by the Zone Measurement to be expanded by the number of additional beam(s) specified as allowable beam.

■ Timing chart

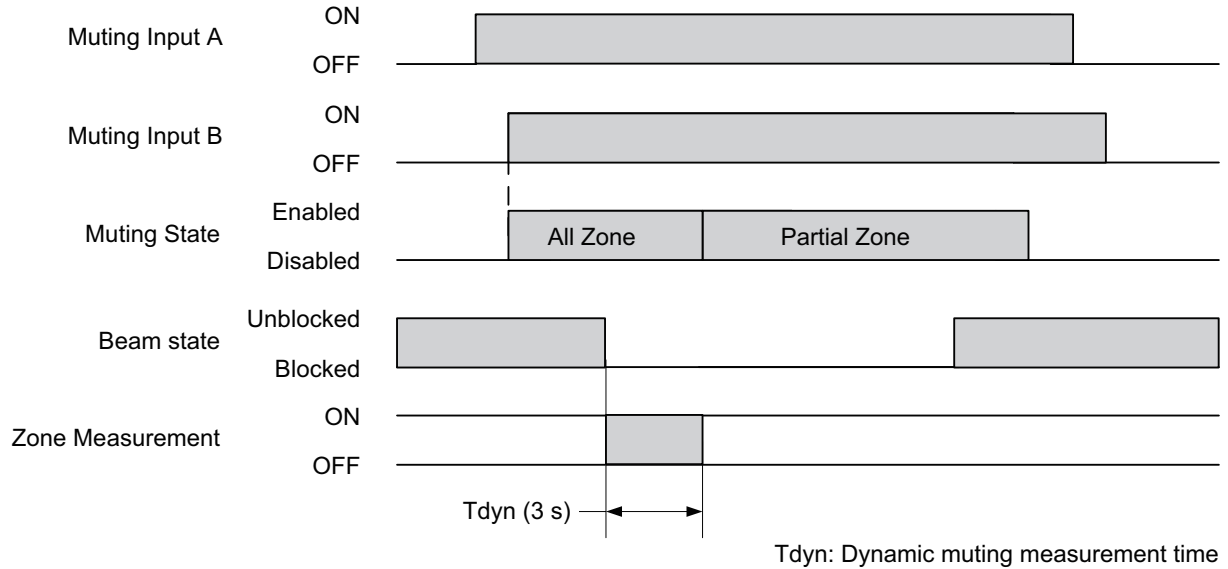

2-12-6. Factory Default Setting

In the factory default setting, the Muting and Dynamic Muting functions are set to Disable.

2-12-7. Setting with Configuration Tool

WARNING

Some settings of functions configurable with the Configuration Tool may increase risks. Make sure the Responsible Person conduct a thorough risk assessment analysis before managing and changing the settings. Unintended changes to the settings may cause a person to go undetected, resulting in serious injury.



The user can make changes to the settings by the Configuration Tool.

Function	Factory Default Setting	Available Parameters
Muting function *	Disable	Enable/Disable
Muting mode	Standard muting mode	Standard muting mode/Exit-only muting mode/Position detection muting mode
Statistics data recording	Disable	Enable/Disable

*Setting parameters of the following functions can be saved according to the states where the Muting function is enabled and disabled, respectively. After changing the Muting function from Enable to Disable or from Disable to Enable, also check the settings of these functions again.

Affected functions: External Device Monitoring (EDM), Start Interlock, Restart Interlock, Auxiliary Output, Lamp Output

Refer to 2-23-6. *Muting Statistics Information* for more information.

Standard Muting Mode

Function		Factory Default Setting	Available Parameters
Muting zone	Bottom beam	All beams	any beam in 1-beam increments
	Top beam		
T1 _{min} : Muting input time limit value (minimum)		0.1 s	0.1 to 3.9 s in 0.1-s increments
T1 _{max} : Muting input time limit value (maximum)		4 s	0.2 to 60 s in 0.1-s increments, or infinite
T2: Muting time limit		60 s	1 to 600 s in 1-s increments, or infinite
T3: Maximum allowable muting signal interruption		0.1 s	0.1 to 20 s in 0.1-s increments

Exit-Only Muting Mode

Function		Factory Default Setting	Available Parameters
Muting zone	Bottom beam	All beams	any beam in 1-beam increments
	Top beam		
T1 _{min} : Muting input time limit value (minimum)		0.1 s	0.1 to 3.9 s in 0.1-s increments
T1 _{max} : Muting input time limit value (maximum)		4 s	0.2 to 4 s in 0.1-s increments, or infinite
T2: Muting time limit		60 s	1 to 600 s in 1-s increments, or infinite
T3: Maximum allowable muting signal interruption		0.1 s	0.1 to 4 s in 0.1-s increments
T4: Muting end wait time		1 s	0.1 to 20 s in 0.1-s increments
T5: Exit-only muting delay time		4 s	4 to 20 s in 0.1-s increments

Position Detection Muting Mode

Function		Factory Default Setting	Available Parameters
Muting zone	Bottom beam	All beams	any beam in 1-beam increments
	Top beam		
T1 _{max} : Muting input time limit value(maximum)		4 s	0.2 to 60 s in 0.1-s increments, or infinite
T2: Muting time limit		60 s	1 to 600 s in 1-s increments, or infinite
T3: Maximum allowable muting signal interruption		0.1 s	0.1 to 4 s in 0.1-s increments

Dynamic Muting

Function	Factory Default Setting	Available Parameters
Dynamic muting	Disable	Enable/Disable
Dynamic muting measurement time	3 s	1 to 25 s in 0.1-s increments
Number of dynamic muting allowable beams	1	0 to 5 in 1-beam increments

 Setting the muting time limit to infinite may cause a failure of the muting sensors to go undetected, resulting in the F3SG-RR in an unintended muting state. Conduct risk assessment analysis thoroughly before enabling this setting.

CHECK!

 Setting the muting input time limit value (maximum) to infinite may cause a failure of the muting sensors to go undetected, resulting in a failure of disabling the muting state. Conduct risk assessment analysis thoroughly before enabling this setting.

CHECK!

 Dynamic Muting can be used in conjunction with any of Standard, Exit-only and Position detection muting modes.

CHECK!

 Refer to *Safety Light Curtain Configuration Tool for Model F3SG (SD Manager 2) User's Manual* for more information on setting this function by the Configuration Tool.

2-13. Override

2-13-1. Overview

The override function turns the safety outputs ON when the muting start condition is not satisfied. If a workpiece stops while passing through the F3SG-RR, as shown below, causing a muting error, the normal state cannot be recovered unless the workpiece is removed from the muting sensors and the detection field of the F3SG-RR. However, the override function will mute the safety outputs of the F3SG-RR so that the conveyor only can be restarted to move the workpiece out of the muting sensors and detection zone.

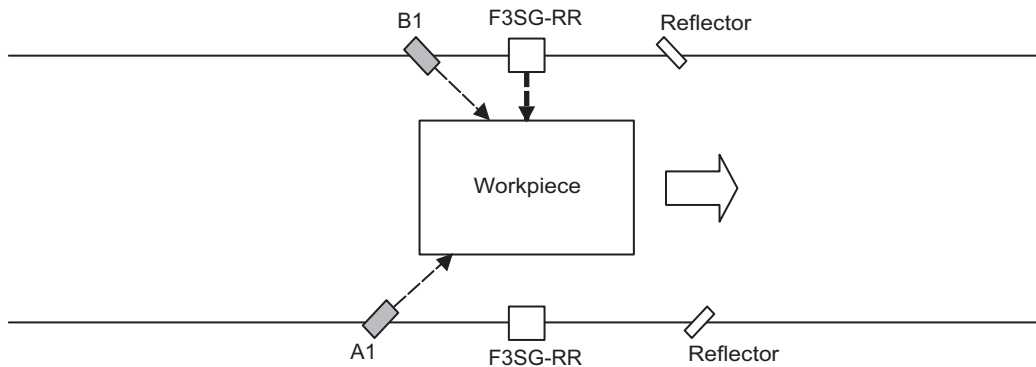

The override function can be enabled for up to 600 s.

Receiver's top-beam-state indicator and bottom-beam-state indicator blink during override.

⚠ WARNING

The muting and override functions disable the safety function of the device. You must ensure safety using other method when these functions are operating.



Install the switch to activate the override function in a location that provides a clear view of the entire hazardous zone and where it cannot be activated from within the hazardous zone. Make sure that nobody is in the hazardous zone before activating the override function.



Override time must be properly configured for its application by a sufficiently trained and qualified person.



Make sure to connect an override cancel switch to the Reset line when using the override function. Otherwise the override state may not be released by the override cancel switch, resulting in serious injury.



When muting error occurs with workpiece blocking the F3SG-RR, there are 2 methods to forcibly remove the workpiece.

- 1) Manual operation (with additional safety measure); or
- 2) Override function (Override at Normal Operation / Override upon Start up)

Only one of the methods, either 1) or 2) must be used.

If they are used at the same time, the override may be activated at an unexpected timing.

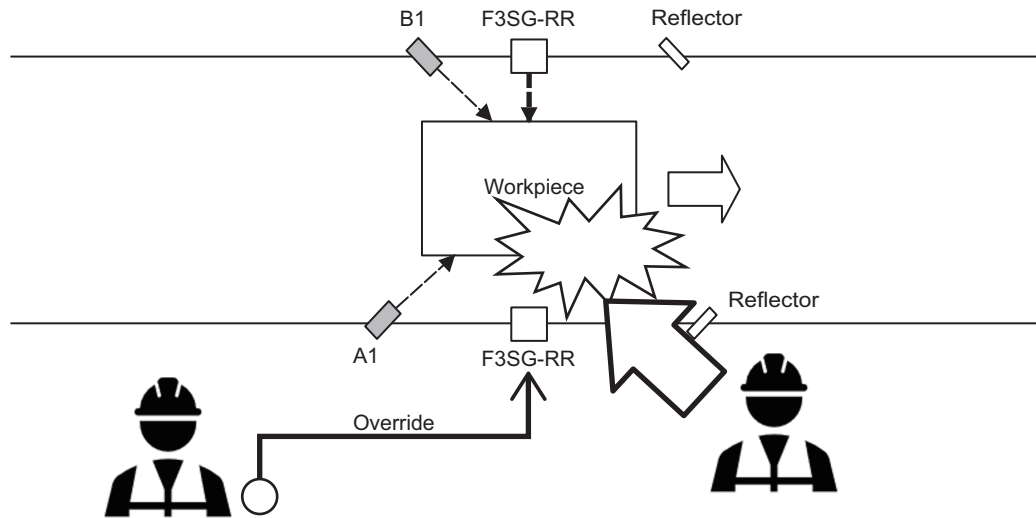

2-13-2. Override at Normal Operation

You can enable the override function under the normal operation.

■ Override start conditions under normal operation

If all of the following conditions are satisfied, the override state is enabled.



The F3SG-RR does not enter Override state when the sensor is in Lockout state.

CHECK!

■ Under standard muting mode

If all of the following conditions are satisfied, the override state is enabled.

1. Either muting input A or B is in the ON state. (One or more muting sensors are turned ON by a workpiece)
2. The F3SG-RR is blocked and the safety outputs are in the OFF state.
3. An input signal of a special sequence is entered three times to the reset input when the conditions No. 1 and 2 above are satisfied. The signal must be entered within a range from 0.1 s to the override input time limit T1 (1 s) (can be changed). (See the timing chart below.)

■ Under position detection muting mode

1. Either muting input A or B detects a mutable position. (Either muting input A is ON or muting input B is OFF)
2. The F3SG-RR is blocked and the output is OFF.
3. Under the state of 1 and 2, provide a special sequence to the reset input three (3) times. The signal must be entered within a range from 0.1 s to the override input time limit T1 (1 s)(can be changed). (See the timing chart below.)

- Under exit-only muting mode

1. Muting sequence error occurred
2. The F3SG-RR is blocked and the output is OFF.
3. Under the state of 1 and 2, a special sequence is entered to the reset input three (3) times. The signal must be entered within a range from 0.1 s to the override input time limit T1 (1 s)(can be changed). (See the timing chart below.)

- Override end conditions under normal operation

When any of the following conditions is satisfied, the override state is released.



CHECK!

Override state can be also released when the F3SG-RR enters the Lockout state.

- Under standard muting mode

1. A period of 600 s (configurable) passes in the OVERRIDE state
2. All muting inputs are turned OFF.
3. The following signal to cancel the OVERRIDE state is entered:
 - When the external device monitoring function is enabled, the RESET line is turned ON. (PNP: Connected to Vs-3 V~Vs; NPN: Connected to 0 V~3 V)
 - When the external device monitoring function is disabled, the RESET line is turned OFF.

- Under position detection muting mode

1. A period of 600 s (configurable) passes in the OVERRIDE state
2. When muting input A is OFF and muting input B is ON
3. The following signal to cancel the OVERRIDE state is entered:
 - When the external device monitoring function is enabled, the RESET line is turned ON. (PNP: Connected to Vs-3 V~Vs; NPN: Connected to 0 V~3 V)
 - When the external device monitoring function is disabled, the RESET line is turned OFF.

- Under exit-only muting mode

1. A period of 600 s (configurable) passes in the OVERRIDE state
2. When F3SG-RR is unblocked
3. The following signal to cancel the OVERRIDE state is entered:
 - When the external device monitoring function is enabled, the RESET line is turned ON. (PNP: Connected to Vs-3 V~Vs; NPN: Connected to 0 V~3 V)
 - When the external device monitoring function is disabled, the RESET line is turned OFF.

■ Timing chart

Under standard muting mode

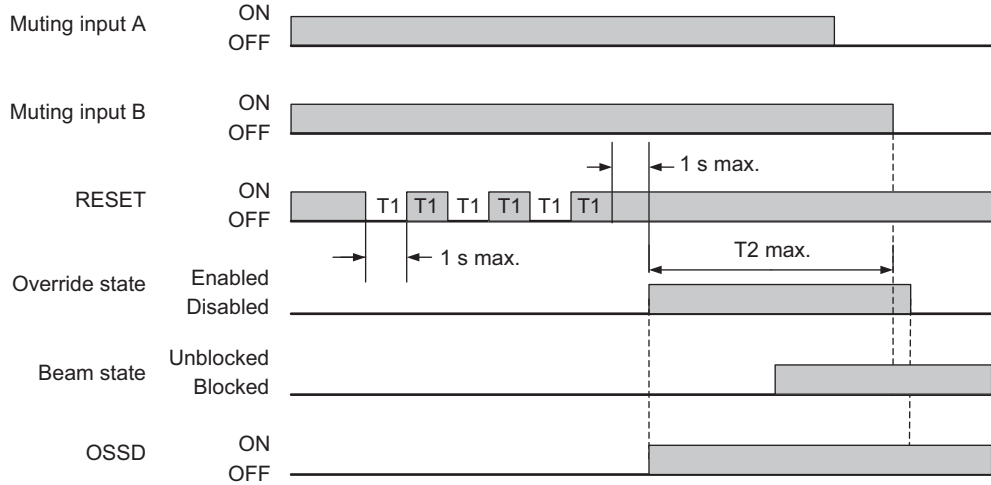

Note. In this timing chart, all muting inputs switched to OFF ends the OVERRIDE state.

Under position detection muting mode

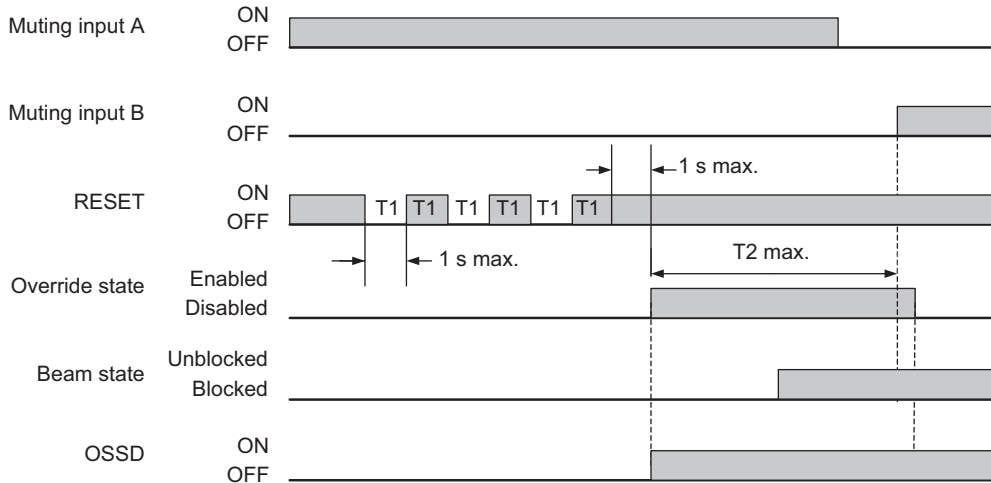

Note. In this timing chart, muting input A switched to OFF and muting input B switched to ON end the OVERRIDE state.

Under exit-only muting mode

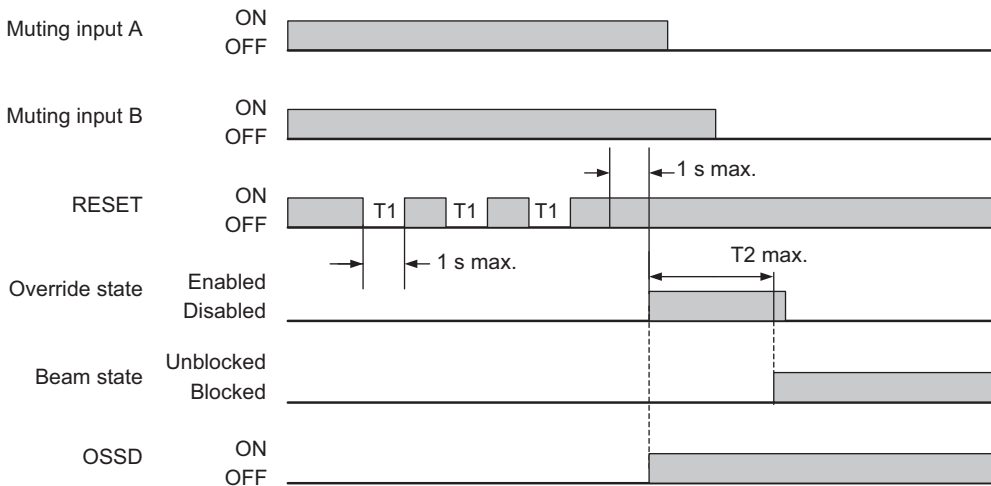

Note. In this timing chart, the F3SG-RR being unblocked ends the OVERRIDE state.

■ Factory default setting

In the factory default setting, the Override function is set to Disable.

■ Basic wiring diagram

- External Device Monitoring used and in Manual Reset mode

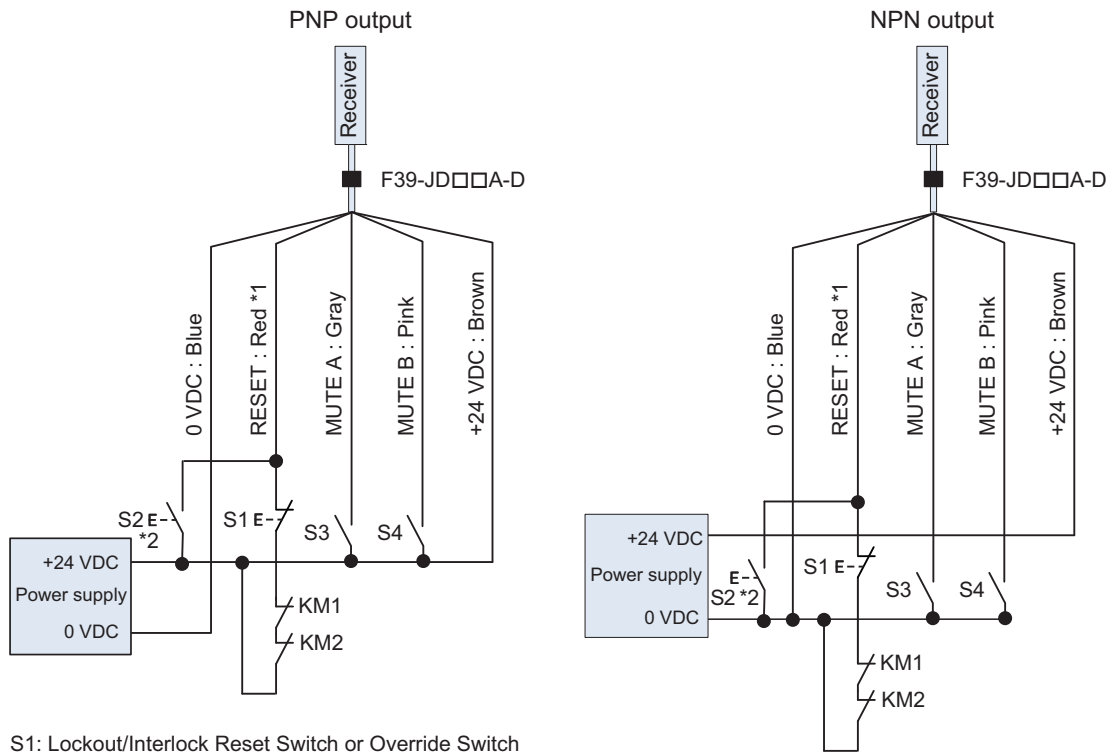

S1: Lockout/Interlock Reset Switch or Override Switch
 S2: Override Cancel Switch
 S3, S4: Muting sensor
 KM1, KM2: External device feedback

*1. Also used as Override input line.
 *2. Make sure to connect an override cancel switch to the Reset line when using the override function. Otherwise the override state may not be released by the override cancel switch, resulting in serious injury.

- External Device Monitoring not used and in Manual Reset mode

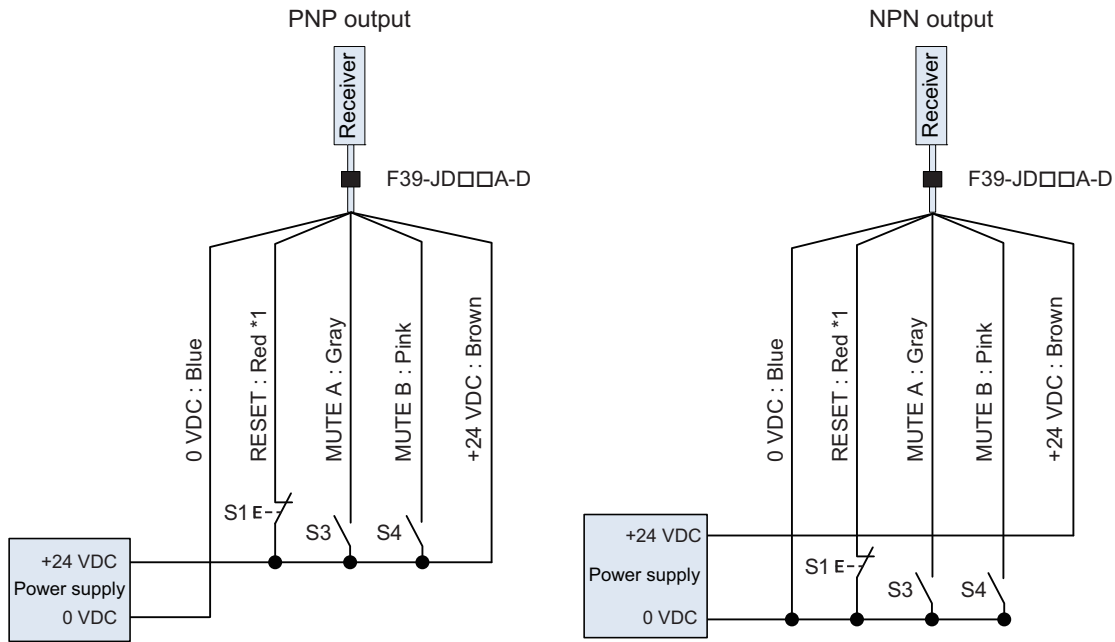

S1: Lockout/Interlock Reset Switch, Override Switch or Override Cancel Switch
 S3, S4: Muting sensor

*1. Also used as Override input line.

2-13-3. Override upon Startup

You can enable the override state by entering a special sequence when the power is turned on. This function is dedicated to exit-only muting mode.

 Under the standard muting mode or the position detection muting mode, a workpiece can be ejected using the override function under the normal operation as any of muting inputs always turns on even if the power is restarted while muting failed.

■ Override start conditions on startup

When all of the following conditions are satisfied, the override state is enabled.

1. Under exit-only muting mode
2. F3SG-RR is blocked
3. Under the state of 2 and 5, a special sequence is entered to the reset input three (3) times. The signal must be entered within a range from 0.1 s to the override input time limit T1 (1 s)(can be changed). (See the timing chart below.)

■ Override end condition on startup

When any one of the following conditions is satisfied, the override state is released.

1. A period of 600 s (configurable) passes in the override state
2. The F3SG-RR is unblocked
3. The following signal to cancel the override state is entered:
 - When the external device monitoring function is enabled, the reset input is turned ON. (PNP: Connected to Vs-3 V~Vs; NPN: Connected to 0 V~3 V)
 - When the external device monitoring function is disabled, the reset input is turned OFF.

 Override state can be also released when the F3SG-RR enters the Lockout state.

■ Timing chart

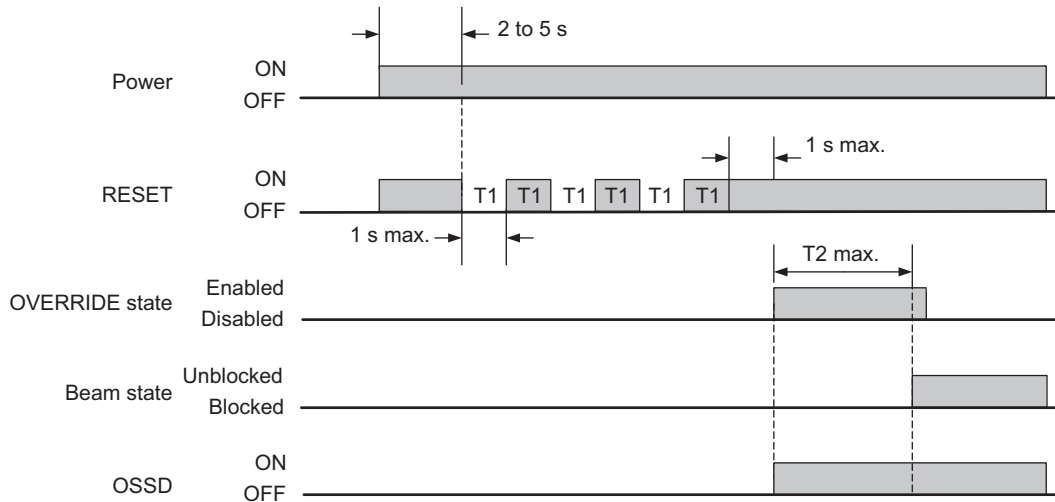

Note. In this timing chart, the F3SG-RR being unblocked ends the OVERRIDE state.

2-13-4. Setting with Configuration Tool

WARNING

Some settings of functions configurable with the Configuration Tool may increase risks. Make sure the Responsible Person conduct a thorough risk assessment analysis before managing and changing the settings. Unintended changes to the settings may cause a person to go undetected, resulting in serious injury.



The user can make changes to the settings by the Configuration Tool.

Function name	Factory Default Setting	Available Parameters
Override	Disable	Enable/Disable
Override input time limit	1 s	0.1 to 5 s in 0.1-s increments
Override time limit	600 s	1 to 600 s in 1-s increments, or infinite

 Setting the override time limit to infinite may cause a failure of disabling the override state when there is a failure of the override input signal. Conduct risk assessment analysis thoroughly before enabling this setting.

CHECK!

 Refer to *Safety Light Curtain Configuration Tool for Model F3SG (SD Manager 2) User's Manual* for more information on setting this function by the Configuration Tool.

2-14. Fixed Blanking

⚠ WARNING

Install protective structure for all zones of disabled zone so that a worker should not be able to approach hazardous zone of a machine without passing through zones disabled by the fixed blanking function.



Otherwise it may result in serious injury.

If allowable beams are designated for fixed blanking, detection capability gets larger near an object that interrupts beams. Calculate a safety distance based on the setting. Otherwise, the machine may not stop before a person reaches the hazardous part, resulting in serious injury.



Responsible Person must ensure that a test rod should be detected in all zones where it should be detected after setting the fixed blanking function. Failure to do so may result in serious injury.



2-14-1. Overview

■ Fixed blanking function

This function disables a part of F3SG-RR detection zone. The safety output stays in the ON state even if an object exists in the disabled zone.

One zone consists of continuous beams for the fixed blanking setting, and the number of zones can be configured up to three zones, from fixed blanking zone 1 to 3. Note that you cannot configure fixed blanking for all beams. In addition, fixed blanking cannot be configured for both beams of the ends (synchronization beams) of the primary sensor at the same time.

■ Fixed blanking zone setting

A zone for fixed blanking zone must be configured with the Configuration Tool. It is possible to perform teaching and set the designated beams manually with the interrupting object placed in the appropriate position. In this example shown below, the 5th and 10th beams are set as bottom and top beams respectively.

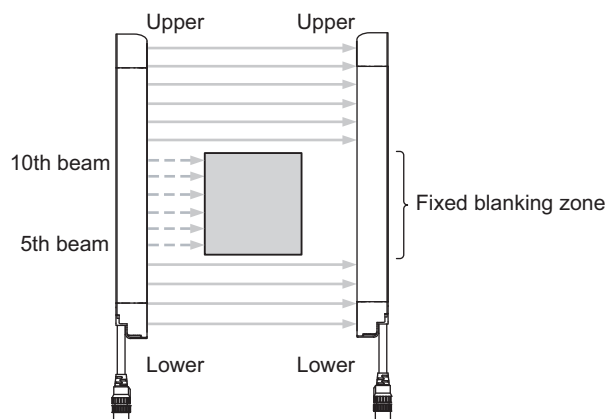

■ Fixed blanking monitoring function

For safety reasons, F3SG-RR transitions to the Lockout state* if part of a fixed blanking zone is unblocked. (Factory default setting.)

When the F3SG-RR is set to Blanking Zone Cancelled, the fixed blanking function is cancelled if part of a fixed blanking zone is unblocked.

In this case, power cycle enables the fixed blanking function again with the same setting as previous one.

Turn off the power and on again while all fixed blanking zones are blocked.

Setting to Monitoring disabled disables the blanking monitoring.

* Allowable beams configured on both ends of fixed blanking zone are not monitored.

■ Allowable beam

Allowable beam represents a beam out of the target of fixed blanking monitoring. This should be configured for a fixed blanking beam that is irregularly blocked and unblocked due to an interrupting object's oscillation. An allowable beam can be assigned to the beams on both ends or one end of a fixed blanking zone.

For allowable beam setting with the Configuration Tool, refer to the user's manual of the Configuration Tool.

 *Safety Light Curtain Configuration Tool for Model F3SG (SD Manager 2) User's Manual*

See below for an example.

In this case, 5th, 6th, and 10th beams are set as allowable beams. These beams is repeatedly blocked and unblocked due to an interrupting object's oscillation. But because these beams are not the target of the monitoring, the F3SG-RR keeps the safety outputs in the ON state.

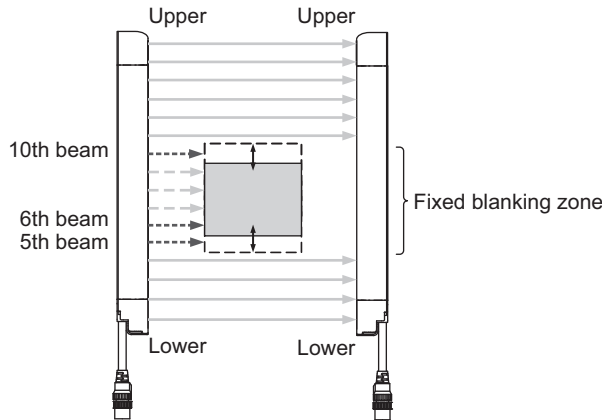

Number of allowable beams available for fixed blanking beams

Number of Fixed Blanking Beams	Maximum Number of Allowable Beams
1	Setting not possible
2	1
3	2
4	3
n	n-1

For detection capability on the border between the blanking zone and normal detection zone when allowable beam is configured, see next table.

Detection capability on the border between the blanking zone and normal detection zone when allowable beam is specified. [mm]

Allowable Beam on One End	F3SG-4RR□□□□-14	F3SG-4RR□□□□-25
Disable	14 (same as nominal)	25 (same as nominal)
1 beam	24	45
2 beams	34	65
n beams	14+(10×n)	25+(20×n)

■ F3SG-RR LED indicator status

When fixed blanking is being enabled, the blanking indicator turns on.

■ Constraint between fixed blanking zones

More than one fixed blanking zone can be configured adjacently (Figures 1 and 2). But allowable beams cannot be set adjacently (Figure 3). You cannot overlap fixed blanking zones. (Figure 4)

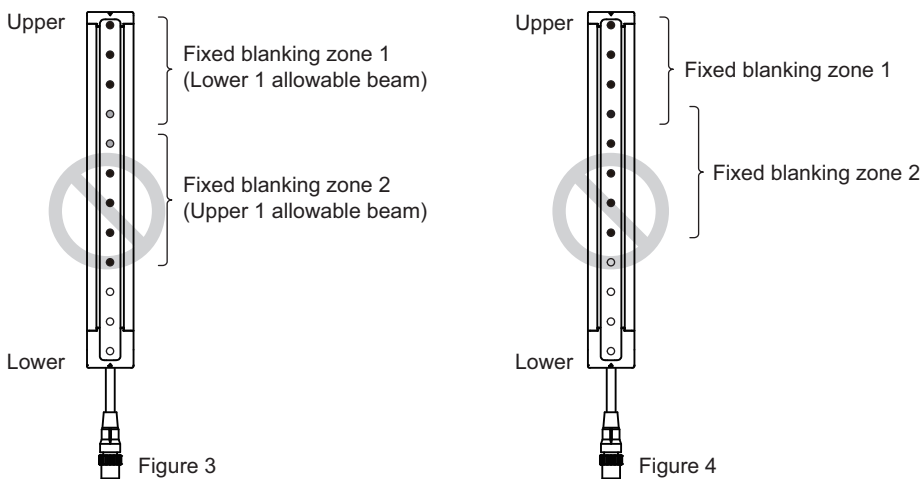
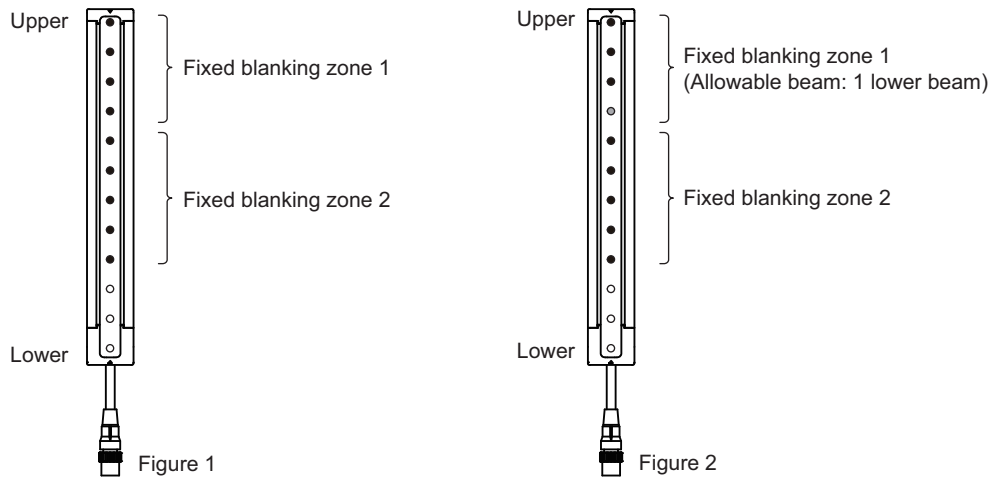

- Normal detecting beam
- Fixed blanking beam
- Allowable beam

■ Limitation for combination with other functions

You can use this function in combination with muting, floating blanking, and warning zone functions at the same time with the Configuration Tool.

Refer to 2-1. *Combination of Functions* for more information on the use in conjunction with other functions.

Settings for respective zone have limitations.

 Refer to 2-18. *Setting Zone Adjacency Conditions* for more information.

2-14-2. Factory Default Setting

The factory default setting is Fixed Blanking Disable.

2-14-3. Setting with Configuration Tool

 **WARNING**

Some settings of functions configurable with the Configuration Tool may increase risks. Make sure the Responsible Person conduct a thorough risk assessment analysis before managing and changing the settings. Unintended changes to the settings may cause a person to go undetected, resulting in serious injury.



The user can make changes to the settings by the Configuration Tool.

Setting is required for each sensor segment in case of a cascade connection.

Function	Factory Default Setting	Available Parameters
Fixed Blanking	Disable	Enable/Disable
Fixed Blanking zone	Bottom beam	1
	Top beam	1
Fixed Blanking Monitoring	Lockout	Lockout/Disable monitoring/Cancel blanking zone
Number of allowable upper beams	0 beam	0 to 5 beams in 1-beam increments
Number of allowable lower beams	0 beam	0 to 5 beams (1-beam increments)

 Setting the Fixed Blanking Monitoring function to Disable Monitoring may create an undetectable area where a person can interrupt the F3SG-RR without being detected, and it is not compliant with IEC 61496-2. Conduct risk assessment analysis thoroughly before enabling this setting.

CHECK!

 Refer to *Safety Light Curtain Configuration Tool for Model F3SG (SD Manager 2) User's Manual* for more information on setting this function by the Configuration Tool.

2-15. Floating Blanking

WARNING

Detection capability gets larger when the floating blanking function is used. When this function is used, the safety distance calculation must be based on the increased detection capability for this function.



Otherwise the machine may not stop before a person reaches to the hazardous part, resulting in serious injury.

Responsible person must ensure that the system works as you intended after configuring floating blanking. Failure to do so may result in serious injury.



If detection capability may get larger and a human body may pass a detection zone to reach a hazardous source, additional safety protection equipment must be installed such as a safety fence.



The F3SG-RR must be installed, configured, and incorporated into a machine control system by a sufficiently trained and qualified person. Unqualified person may not be able to perform these operations properly, which may cause a person to go undetected, resulting in serious injury



2-15-1. Overview

■ Floating blanking function

This function allows a specified number of beams to move freely in the detection zone of the F3SG-RR while keeping the safety outputs in the ON state.

 Refer to 2-1. *Combination of Functions* for more information on the use in conjunction with other functions.

■ Floating blanking zone

All beams are configured as a floating blanking zone. If the zone overlapped with that of other function (e.g. fixed blanking, warning zone), the other function is prioritized in the overlapped zone.

■ Floating beam

The number of beams that prevents the safety outputs to be turned OFF can be configured by setting the number of floating beams with the Configuration Tool.

■ Floating blanking monitoring function

F3SG-RR monitors an interrupting object in a floating blanking zone. (If the object is removed or gets smaller, human entry may not be detected by F3SG-RR, resulting in serious injury.)

F3SG-RR enters lockout when an interrupting object becomes smaller, or removed. (Factory default setting)

It is possible to configure the blanking monitoring function to be disabled when an interrupting object is smaller or removed.

In case configured as Blanking Disable, if an interrupting object gets smaller than the setting value, the floating blanking function is canceled. That is, the entire detection zone of F3SG-RR works as the normal detection zone.

If Temporality Disable Monitoring by Wiring is configured, the monitoring function can be temporarily disabled during operation by hard wiring of muting input A and muting input B. For details, see below.



If Temporality Disable Monitoring by Wiring is configured, muting function cannot be used.

CHECK!

Temporarily disable monitoring by external wiring

If Temporarily Disable Monitoring by Wiring is configured, the floating blanking monitoring function can be temporarily disabled during operation by hard wiring of muting input A and muting input B of a receiver.

The blanking monitoring function is disabled for a period of T2 by turning muting input A from OFF to ON and muting input B from ON to OFF within an input time difference T1 (4s) using a limit switch, etc. Inputs of muting input A and muting input B must be redundant inputs of different kinds such as a combination of NO contact and NC contact types. (When using photoelectric sensors of PNP output, use one for Light-ON operation while the other for Dark-ON.) This mode can be used for such a case that the F3SG-RR should be temporarily disabled while a worker puts objects at a loading station.

The user can use this function only when the F3SG-RR is used as a one segment system and the function is enabled by the Configuration Tool. The function cannot be enabled when the F3SG-RR is in the cascade connection.

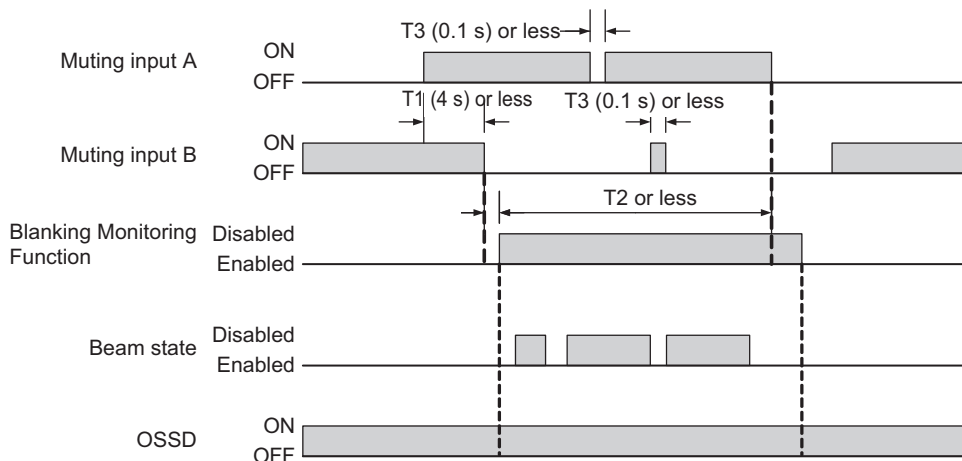

T1: Muting input limit (fixed to 4 s)

The maximum value of an input time difference between muting input A/B. Configured as 4 s.

T2: Monitoring Temporarily Disabled Time Limit

A time limit to disable blanking monitoring. When this time period passed, the blanking monitoring function is enabled, and lockout occurs if the blanked beam is unblocked. The factory default setting is 10 s (configurable).

T3: Maximum allowable muting signal interruption (fixed to 0.1 s)

Maximum duration of a signal interruption allowed in Muting inputs A and B. This is set at 0.1 s.

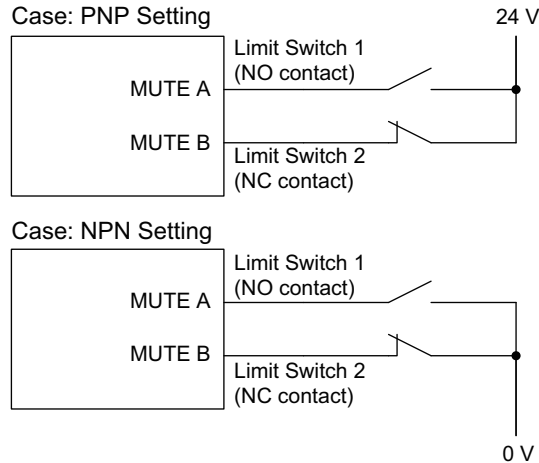

The muting is not enabled when the Temporality Disable Monitoring by External Wiring is enabled.

■ Number of allowable beams

Number of beams in the Floating Blanking zone, that are not monitored by the Floating Blanking Monitoring function.

When the Floating Blanking Monitoring function is enabled and the number of blocked beams becomes less than "the number of Floating beams - the number of allowable beam(s)", the F3SG-RR enters the Lockout state.

Setting Example: the F3SG-RR with 14-mm detection capability

When the number of floating beams is configured as 4 beams, the safety output is turned OFF if 5 or more beams are blocked. (Fig. 1)

If the number of floating beams is configured as 4 beams, the safety outputs are not turned OFF if 4 or less beams are blocked. (Fig. 2)

If the monitoring function is being enabled and the number of allowable beams is configured as 1 beam, lockout occurs when an interrupting object is lost or 2 or less beams are blocked. (Fig. 3)

When an interrupting object of the size that does not turn off the safety outputs interrupts multiple locations, the safety outputs are not turned OFF. (Fig. 4)

5 or more beams are blocked

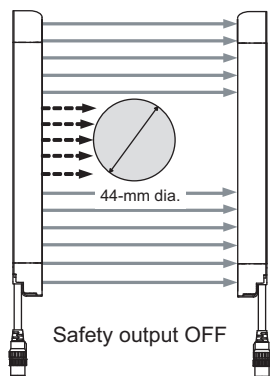

Fig.1

4 or fewer are blocked

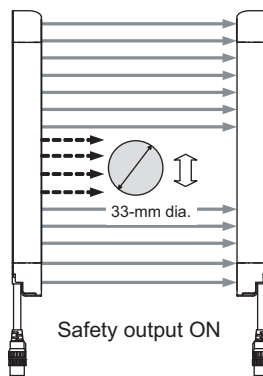

Fig. 2

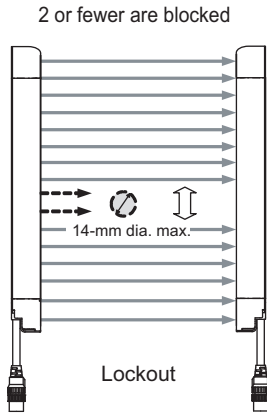

Fig. 3

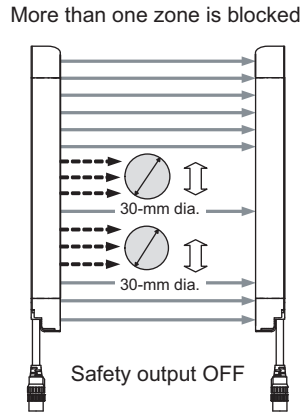

Fig. 4

■ Detection capability

Detection capability for F3SG-RR differs based on the number of floating beams as shown below.

Model	Number of beams configured	Detection capability	Number of blocked beams to turn safety outputs OFF
F3SG-4RR□□□□-14	-	14 mm	1 beam
	1 beam	24 mm	2 beams
	2 beams	34 mm	3 beams
	3 beams	44 mm	4 beams
	4 beams	54 mm	5 beams
	n beams	$14+(10 \times n)$ mm	(n+1) beams
F3SG-4RR□□□□-25	-	25 mm	1 beam
	1 beam	45 mm	2 beams
	2 beams	65 mm	3 beams
	3 beams	85 mm	4 beams
	4 beams	105 mm	5 beams
	n beams	$25+(20 \times n)$ mm	(n+1) beams

■ F3SG-RR LED indicator status

When floating blanking is being enabled, the Blanking indicator turns on.

■ Limitation for combination with other functions

You can use this function in combination with muting, fixed blanking, and warning zone functions at the same time with the setting tool for F3SG-RR. Settings for respective zone have limitations.

 Refer to 2-1. *Combination of Functions* for more information on the use in conjunction with other functions.

2-15-2. Factory Default Setting

The factory default setting is the Floating Blanking Disabled.

2-15-3. Setting with Configuration Tool

WARNING

Some settings of functions configurable with the Configuration Tool may increase risks. Make sure the Responsible Person conduct a thorough risk assessment analysis before managing and changing the settings. Unintended changes to the settings may cause a person to go undetected, resulting in serious injury.



The user can make changes to the settings by the Configuration Tool.

Setting is required for each sensor segment in case of a cascade connection.

Function	Factory Default Setting	Available Parameters
Floating Blanking	Disable	Enable/Disable
Floating Blanking Monitoring	Lockout	Disable monitoring/Lockout/Cancel blanking zone
Temporarily Disable Monitoring Function	Disable	Enable/Disable
Monitoring temporarily disabled time limit	10 s	1 to 200 s (1-s increments), or infinite
Number of floating beams	1	1 to 15 (1-beam increments)
Number of allowable beams	0	0 to 5 (1-beam increments)



Setting the Floating Blanking Monitoring function to Disable Monitoring may create an undetectable area where a person can interrupt the F3SG-RR without being detected, and it is not compliant with IEC 61496-2. Conduct risk assessment analysis thoroughly before enabling this setting.

CHECK!



Refer to *Safety Light Curtain Configuration Tool for Model F3SG (SD Manager 2) User's Manual* for more information on setting this function by the Configuration Tool.

2-16. Reduced Resolution

2-16-1. Overview

The reduced resolution function prevents the safety output to turn off by an object moving in a detection zone. With this function, an object with a size of 1 to 3 beams can be ignored by changing a detection capability size. Unless the number of continuously blocked beams exceeds the setting (1 to 3 beams), the total number of blocked beams has no limit. The response time remains the same even when the detection capability is changed.

The difference from the Floating Blanking is that the Reduced Resolution keeps the safety outputs ON even when an object is present discontinuously.

 Refer to 2-1. *Combination of Functions* for more information on the use in conjunction with other functions.

Example:

- Enter of a person into the detection zone is monitored while enter of a transport dolly is allowed.

Example:

The F3SG-RR does not turn the safety outputs OFF when the number of blocked continuous beams is 3 or more. (Fig. 1)

The F3SG-RR does not turn the safety outputs OFF when the number of blocked continuous beams is 2 or less. (Fig. 2)

The F3SG-RR does not turn the safety outputs OFF when there are some combinations of continuously blocked beams in a detection zone but the number of the continuously blocked beams of each combination is 2 or less. (Fig. 3)

The F3SG-RR does not go to the Lockout state and does not turn the safety outputs OFF even when an object has been removed from the detection zone. (Fig. 4)

3 or more beams are blocked

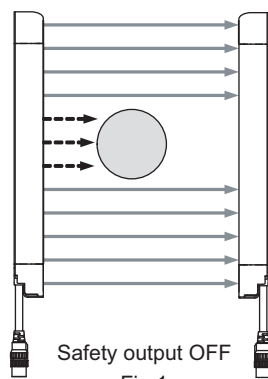

2 or fewer are blocked

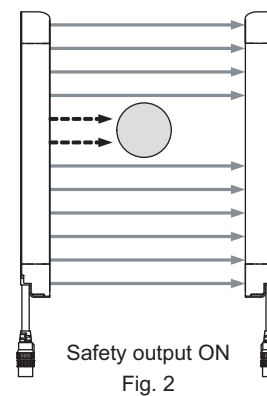

Multiple combinations of beams are blocked
(Each combination consists of 2 or fewer beams)

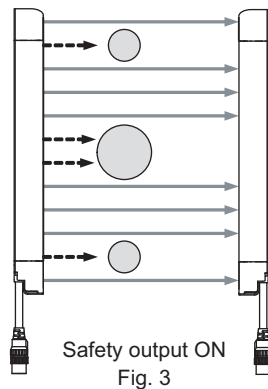

Unblocked

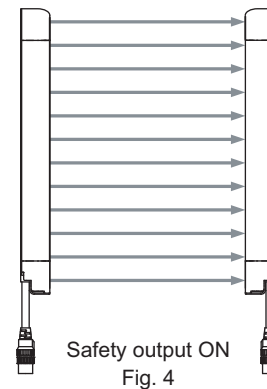

⚠ WARNING

Detection capability gets larger when the reduced resolution function is used. When this function is used, the safety distance calculation must be based on the increased detection capability for this function. Otherwise, the machine may not stop before a person reaches the hazardous part, resulting in serious injury.



If detection capability may get larger and a human body may pass a detection zone to reach a hazardous source, additional safety protection equipment must be installed such as a safety fence.



The F3SG-RR must be installed, configured, and incorporated into a machine control system by a sufficiently trained and qualified person. Unqualified person may not be able to perform these operations properly, resulting in failure of human body detection and heavy injury.



■ **Detection capability**

Detection capability for F3SG-RR differs based on the number of floating beams as shown below.

Model	Number of beams configured	Detection capability	Number of blocked beams to turn safety outputs OFF	Maximum diameter of object ignored
F3SG-4RR□□□□-14	-	14 mm	1 beam	-
	1 beam	24 mm	2 beams	6.6 mm
	2 beams	34 mm	3 beams	16.6 mm
	3 beams	44 mm	4 beams	26.6 mm
F3SG-4RR□□□□-25	-	25 mm	1 beam	-
	1 beam	45 mm	2 beams	13 mm
	2 beams	65 mm	3 beams	33 mm
	3 beams	85 mm	4 beams	53 mm

■ **F3SG-RR LED indicator status**

When the Reduced Resolution is being enabled, the Blanking indicator turns on.

 Refer to 2-1. *Combination of Functions* for more information on the use in conjunction with other functions.

2-16-2. Factory Default Setting

The factory default setting is the Reduced Resolution Disable.

2-16-3. Setting with Configuration Tool

WARNING

Some settings of functions configurable with the Configuration Tool may increase risks. Make sure the Responsible Person conduct a thorough risk assessment analysis before managing and changing the settings. Unintended changes to the settings may cause a person to go undetected, resulting in serious injury.



The user can make changes to the settings by the Configuration Tool.

Function Name	Factory Default Setting	Available Parameters
Reduced Resolution	Disable	Enable*/Disable
Number of beams	1	1 to 3 beams in 1-beam increments

*It is not possible to configure the Reduced Resolution function together with the Muting function. To enable settings of the Reduced Resolution function, disable the Muting function.

In addition, setting parameters of the following functions can be saved according to the states where the Muting function is enabled and disabled, respectively. After changing the Muting function from Enable to Disable or from Disable to Enable, also check the settings of these functions again.

Affected functions: External Device Monitoring (EDM), Start Interlock, Restart Interlock, Auxiliary Output, Lamp Output

 Refer to *Safety Light Curtain Configuration Tool for Model F3SG (SD Manager 2) User's Manual* for more information on setting this function by the Configuration Tool.

2-17. Warning Zone

2-17-1. Overview

Part of the detection zone can be set as a warning zone.

Example:

- When a person enters, indicator or buzzer should notify warning without stopping a machine.

WARNING

When a warning zone is configured, you must attach labels that indicate a border between normal detection zone and warning zone. Otherwise the machine may not stop before a person reaches to the hazardous part, resulting in serious injury.



A warning zone must not be used for safety applications. Always install your system so that a detection zone should be passed before reaching a hazardous part of the machine. If access to the hazardous part by reaching over the detection zone of a vertically mounted F3SG-RR cannot be excluded, the height of the detection zone and the safety distance shall be determined in consideration of such a risk.

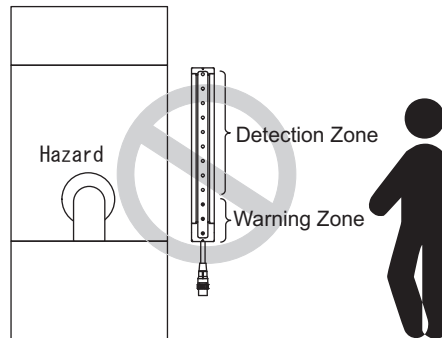

A warning zone must be configured based on a safety distance.

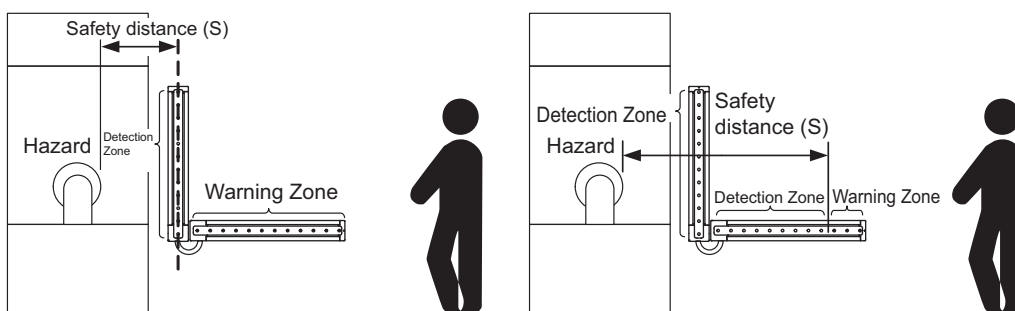

 Refer to 4-1-2. *Safety Distance* for more information on safety distance calculations for orthogonal and parallel approaches.

You can specify beams you want to configure for warning zone. (Fig. 4& 5)

Configuration cannot be executed for cases shown below.

- All beams are configured as a warning zone (Fig. 7).
- A warning zone is specified without including any of end beams (Fig. 8)

When it is configured for the F3SG-RR in cascade connection to have the detection zone, it is possible for the other F3SG-RR's to have the warning zone for the all beams. (Fig. 6)

 For the application as shown in Fig. 6, make sure the primary sensor has the detection zone and the secondary sensor has the warning zone.
CHECK!

■ Operation example

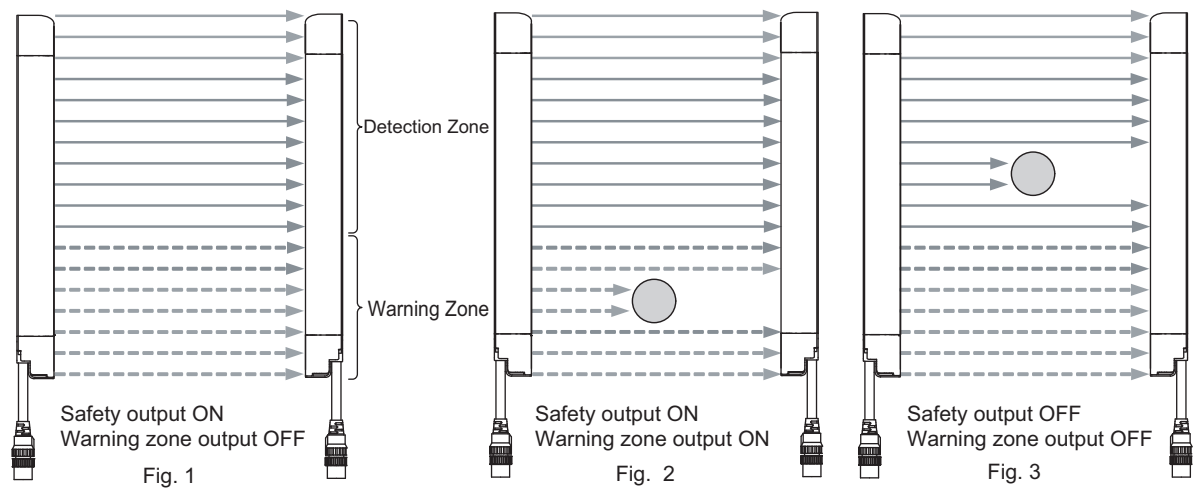

■ Timing chart

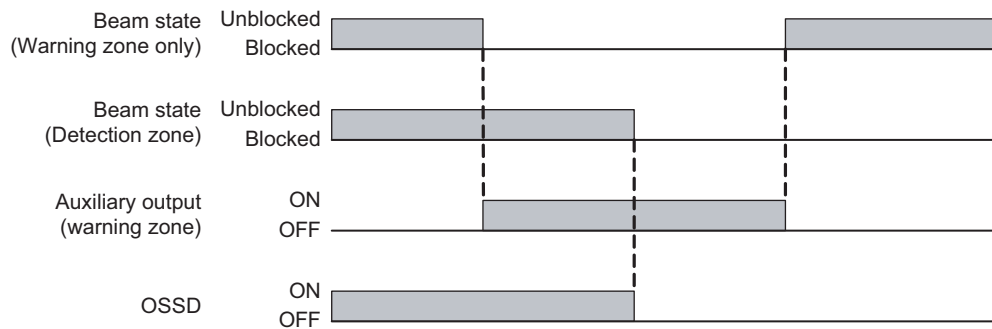

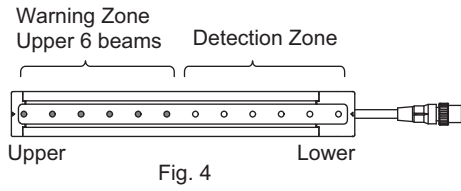

Fig. 4

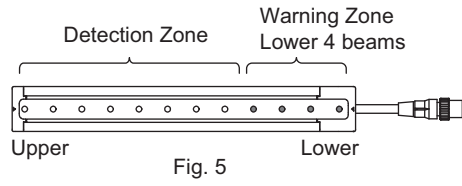

Fig. 5

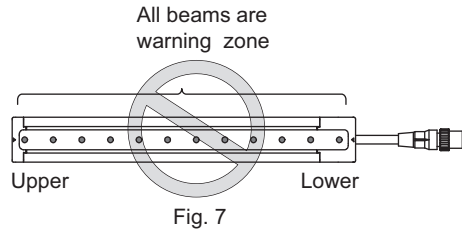

Fig. 7

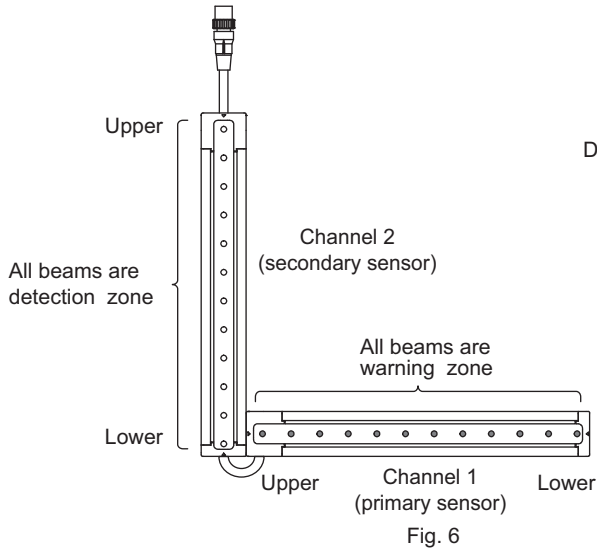

Fig. 6

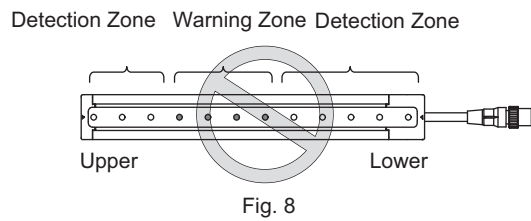
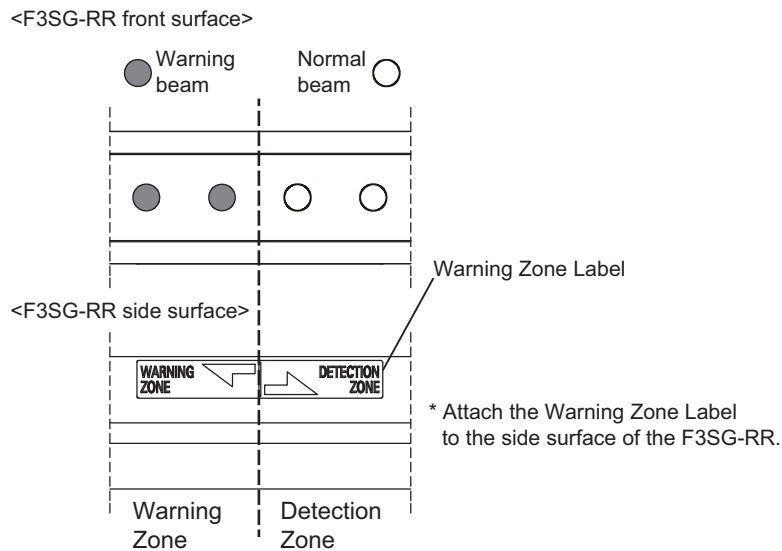

Fig. 8

When a warning zone is configured, you must attach labels that indicate a border between normal detection zone and warning zone.



The Blanking indicator of the F3SG-RR is illuminated when the Warning Zone is enabled.

Refer to 2-1. *Combination of Functions* for more information on the use in conjunction with other functions.

2-17-2. Factory Default Setting

The factory default setting is Warning Zone Disable.

2-17-3. Setting with Configuration Tool

WARNING

Some settings of functions configurable with the Configuration Tool may increase risks. Make sure the Responsible Person conduct a thorough risk assessment analysis before managing and changing the settings. Unintended changes to the settings may cause a person to go undetected, resulting in serious injury.



The user can make changes to the settings by the Configuration Tool.

Function	Factory Default Setting	Available Parameters
Warning zone	Disable	Disable/Enable from upper/Enable from lower
Zone setting	None	Any beam from top beam/any beam from bottom beam

If you want to output the light unblocked/blocked states of the warning zone, configure the output operation mode of the auxiliary output or Lamp as warning zone information.

 Refer to *Safety Light Curtain Configuration Tool for Model F3SG (SD Manager 2) User's Manual* for more information on setting this function by the Configuration Tool.

2-18. Setting Zone Adjacency Conditions

If any two functions of muting, fixed blanking or warning zone functions of the F3SG-RR are used at the same time, the setting zones have limitations.

This section describes the limitations for following points:

1. Zone adjacent condition: If zones for multiple functions are configured adjacently
2. Zone overlap condition: If zones for multiple functions are configured as overlapped

1. Zone Adjacency Condition

The table below describes the conditions to configure setting zones for adjacent beams.

Except for some conditions, setting zones for these 3 functions can be located adjacently. The user can make the setting by the Configuration Tool.

Zone Adjacency Condition

Function	Muting	Fixed Blanking	Warning Zone
Muting	-	Yes	Yes
Fixed Blanking	Yes	*	Yes
Warning Zone	Yes	Yes	-

Yes: Possible to configure

* For details about setting adjacent fixed blanking zones.



Refer to *Constraint between fixed blanking zones* under 2-14. *Fixed Blanking*.

2. Zone Overlap Condition

The table below describes the conditions to configure setting zones for overlapping beams.

Except for combination of muting zone and fixed blanking zone (Figure 1), setting zones of these 3 functions cannot be overlapped. (Figure 2)

The user can make the setting by the Configuration Tool.



Setting zones of Muting and Floating functions can be overlapped only if each zone covers the full detection zone.

CHECK!

Zone overlap condition

Function	Muting	Fixed Blanking	Warning Zone
Muting	-	Yes	No
Fixed Blanking	Yes	No	No
Warning Zone	No	No	-

Yes: Possible to configure

No: Not possible to configure

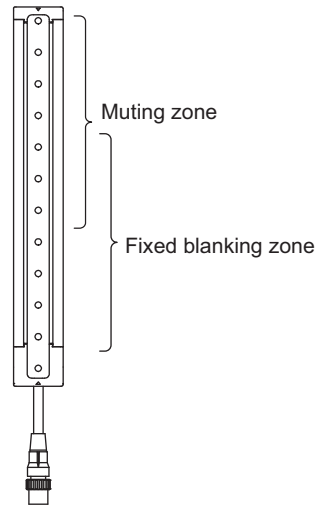

Figure 1

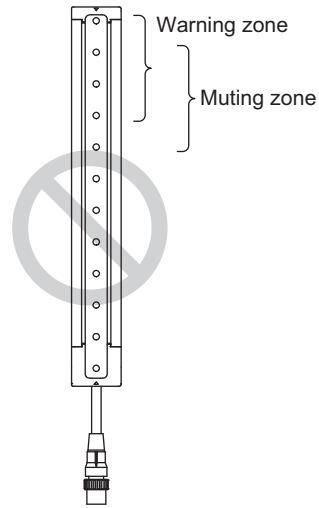

Figure 2



Even if a muting zone and a fixed blanking zone are configured as overlapped, fixed blanking monitoring function is effective.

2-19. Response Time Adjustment

2-19-1. Overview

The Response Time Adjustment function allows the user to select the longer response time in order to reduce the chance the safety outputs are turned OFF by an accidental block of the F3SG-RR due to an environmental factor. Environmental factors include noise, smoke, dust, and bugs.

WARNING

To change the response time, calculate the safety distance based on the setting. Otherwise, the machine may not stop before a person reaches the hazardous part, resulting in serious injury.



2-19-2. Factory Default Setting

In the factory default setting, the response time is configured to the normal mode.

 For the response time of factory default setting, see 1-6-1. *List of Models/Response Time/Current Consumption/Weight*

2-19-3. Setting with Configuration Tool

WARNING

Some settings of functions configurable with the Configuration Tool may increase risks. Make sure the Responsible Person conduct a thorough risk assessment analysis before managing and changing the settings. Unintended changes to the settings may cause a person to go undetected, resulting in serious injury.



The user can make changes to the settings by the Configuration Tool.

Function	Factory Default Setting	Available Parameters
Response Time Adjustment	Normal mode	Normal mode/Slow mode

The ON-to-OFF response time of the Slow mode is doubled compared to the Normal mode.

 Refer to *Safety Light Curtain Configuration Tool for Model F3SG (SD Manager 2) User's Manual* for more information on setting this function by the Configuration Tool.

2-20. Lamp

2-20-1. Overview

A lamp (F39-LP and F39-BTLP, sold separately) can be connected to a receiver and turned ON based on the operation of F3SG-RR. The lamp can indicate red, orange, and green colors, to which three different states can be assigned. When there are several illumination conditions, the priority of the colors to illuminate or blink is red > orange > green.

Usage Example:

- Indicate that F3SG-RR is in muting or override
- Indicate that F3SG-RR is under lockout
- Indicate that a machine is stopped (safety output is in the OFF state)
- Illuminate along with the operation of a machine such as picking operation, using Mute A and Mute B Input Information signals



CHECK!

Refer to the instruction sheet of the Lamp for more information.



CHECK!

The lamp is not intended to be used for the emitter. Do not connect the lamp to the emitter.

2-20-2. Factory Default Setting

The factory default setting is Red as inverted signal of the safety output information, Orange as inverted signal of the stable-state information and ON 1 time*, Green as the safety output information.

* Refer to *Output pattern chart* below.

2-20-3. Setting with Configuration Tool

WARNING

Some settings of functions configurable with the Configuration Tool may increase risks. Make sure the Responsible Person conduct a thorough risk assessment analysis before managing and changing the settings. Unintended changes to the settings may cause a person to go undetected, resulting in serious injury.



The user can make changes to the settings by the Configuration Tool.

Lamp output	Function	Factory Default Setting		Available Parameters
		Muting function *1		
		Enabled	Disabled	
Red (Priority 1)	Output operation mode	Safety output information	Safety output information	*2
	Inverted signal output	Enable	Enable	Enable/Disable
	Output pattern	Solid-ON	Solid-ON	Solid-ON/ON 1 time/ON 2 times/ON 3 times *3
Orange (Priority 2)	Output operation mode	Stable-state information	Stable-state information	*2
	Inverted signal output	Enable	Enable	Enable/Disable
	Output pattern	ON 1 time	ON 1 time	Solid-ON/ON 1 time/ON 2 times/ON 3 times *3
Green (Priority 3)	Output operation mode	Safety output information	Safety output information	*2
	Inverted signal output	Disable	Disable	Enable/Disable
	Output pattern	Solid-ON	Solid-ON	Solid-ON/ON 1 time/ON 2 times/ON 3 times *3

*1. Setting parameters of this function can be saved according to the states where the Muting function is enabled and disabled, respectively. After changing the Muting function from Enable to Disable or from Disable to Enable, also check the settings of this function again.

 Refer to ■ Considerations for enabling and disabling Muting function under 2-1. Combination of Functions for more information.

 Refer to 2-12. Muting for more information on settings of the Muting function.

*2. Refer to the table of Information (Output operation mode) assigned to Lamp below.

*3. The Lamp illuminates according to the patterns as shown in the output pattern chart below.

■ Output pattern chart

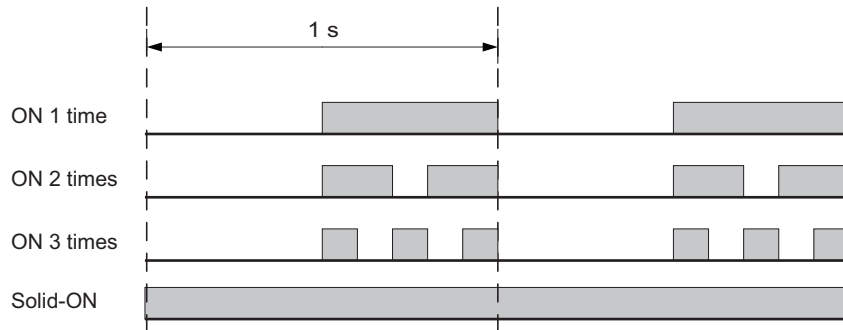

■ Information (Output operation mode) assigned to Lamp

Information Name	Description (Lamp turns ON or blinks under the following condition)
Safety output information	When Safety output is in the ON state
Interlock information	Under Interlock state
Lockout information	Under error/ Lockout state
Excess power-on time information	When power-on time exceeds power-on time threshold
Excess load switching frequency information	When load switching frequency exceeds load switching frequency threshold
Stable-state information	When light intensity, which is consistently monitored, is 170% or higher of ON-threshold
Muting information	Under Muting state
Override information	Under Override state
Muting/Override information	Under either Muting or Override state

Information Name	Description (Lamp turns ON or blinks under the following condition)
Light level diagnosis information	When the F3SG-RR is unblocked and light intensity is within a range from 100% to 170% of ON-threshold for 10 s or longer
Warning Zone Information	When warning zone is blocked
Blanking beam unblocked information	When Fixed-Blanking or Floating Blanking beams are unblocked
Troubleshooting support signal	When one of the signals of Sequence error information, Interference/vibration information and Light level diagnosis information is in the ON state.
Designated beam output information	When a designated beam is blocked or unblocked
Sequence error information	Under Muting sequence error state or Interlock sequence error state
Reset-input information	When Reset/EDM/Override input is in the ON state
Mute A input information	When muting input A is in the ON state
Mute B input information	When muting input B is in the ON state
EDM input information	When EDM signal input is in the ON state
Individual cascaded sensor output (Channel 1)	When Safety output of Primary sensor in cascade connection is the ON state
Individual cascaded sensor output (Channel 2)	When Safety output of 1st Secondary sensor in cascade connection is the ON state
Individual cascaded sensor output (Channel 3)	When Safety output of the 2nd Secondary sensor in cascade connection is the ON state
Blanking/Warning-zone information	When Fixed Blanking, Floating Blanking, Reduced Resolution or Warning Zone function is enabled
Interference/vibration information	When the F3SG-RR system stops accidentally due to interference or vibration. (In case of cascade connection, when any of cascaded segments comes under this condition.)
Pre-reset Information	Under Pre-reset state

 Refer to *Safety Light Curtain Configuration Tool for Model F3SG (SD Manager 2) User's Manual* for more information on setting this function by the Configuration Tool.

2-21. Designated Beam Output

2-21-1. Overview

This function allows information on unblocked/blocked states of a given beam to be output.

Example:

- To turn a Lamp ON when a specified beam of F3SG-RR is blocked
- To output, from the auxiliary output, a signal of information on a specified beam being unblocked

If one or more specified beams are blocked or unblocked, the information on the beam state can be provided as an auxiliary output or indication of Lamp.

Operation Example

Designated beam state: Dark-ON

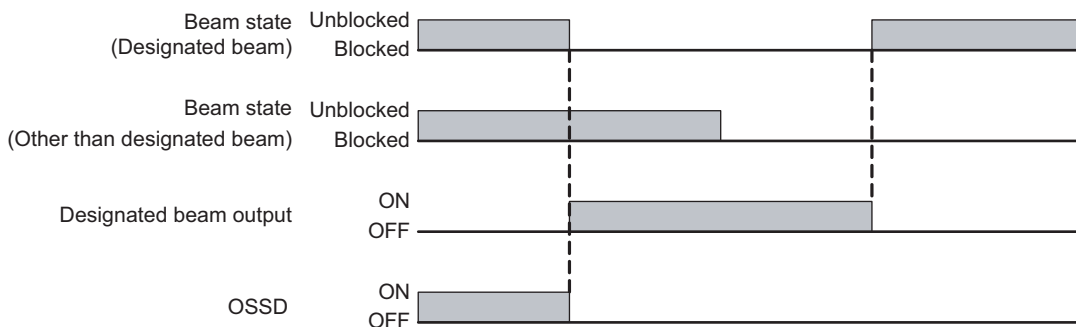
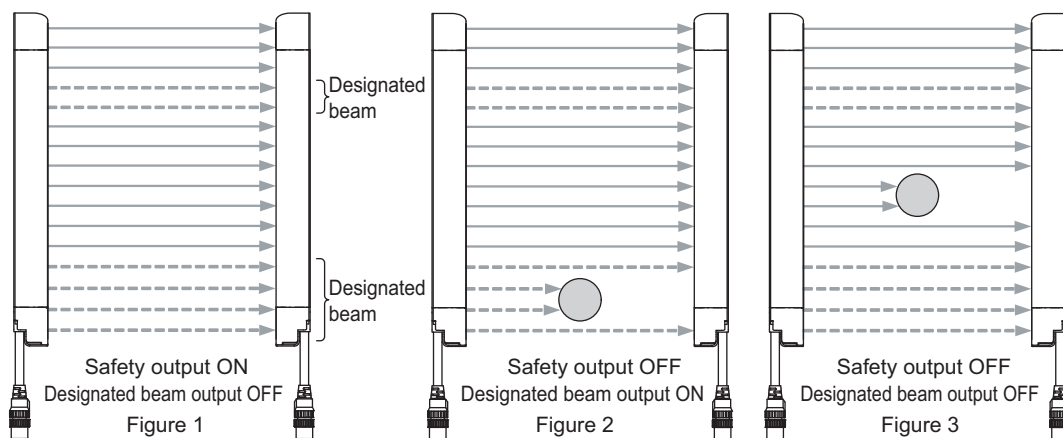

2-21-2. Factory Default Setting

The factory default setting is Designated Beam Output as Disable.

2-21-3. Setting with Configuration Tool

WARNING

Some settings of functions configurable with the Configuration Tool may increase risks. Make sure the Responsible Person conduct a thorough risk assessment analysis before managing and changing the settings. Unintended changes to the settings may cause a person to go undetected, resulting in serious injury.



The user can make changes to the settings by the Configuration Tool.

Function		Factory Default Setting	Available Parameters
Designated beam output		Disable	Enable/Disable
Designated beam zone	Bottom beam	-	Any beam in 1-beam increments
	Top beam	-	
Designated beam state		Light-ON	Light-ON/Dark-ON

If you want to output the light unblocked/blocked states of a designated beam, configure any one of the output operation modes of auxiliary output or Lamp as designated beam output information.

 Refer to *Safety Light Curtain Configuration Tool for Model F3SG (SD Manager 2) User's Manual* for more information on setting this function by the Configuration Tool.

2-22. Light Level Monitoring

2-22-1. Incident Light Level Information

2-22-1-1. Overview

The user can use the Configuration Tool to read incident light level of the F3SG-RR and view on a PC screen. This function allows beam adjustment while checking receiving incident light level.

2-22-1-2. Setting with Configuration Tool

The user can enable this function to retrieve incident light level information. Making any changes to the function is not possible. (When the F3SG-RR is in the cascade connection, incident light level of each segment can be retrieved.)

2-22-2. Ambient Light Level Information

2-22-2-1. Overview

The user can use the Configuration Tool to read incident light level of ambient light from a photoelectric sensor or another F3SG-RR unit in a close area and view it on a PC screen. This function allows the user to identify a photoelectric sensor radiating ambient light or beams being affected by the light.

2-22-2-2. Setting with Configuration Tool

The user can enable this function to retrieve ambient light level information. Making any changes to the function is not possible. (When the F3SG-RR is in the cascade connection, ambient light level of each segment can be retrieved.)



Refer to *Safety Light Curtain Configuration Tool for Model F3SG (SD Manager 2) User's Manual* for more information on setting this function by the Configuration Tool.

2-23. Maintenance Information

WARNING

Some settings of functions configurable with the Configuration Tool may increase risks. Make sure the Responsible Person conduct a thorough risk assessment analysis before managing and changing the settings. Unintended changes to the settings may cause a person to go undetected, resulting in serious injury.



2-23-1. Overview

You can use the Configuration Tool to read the maintenance information of F3SG-RR to view on a PC screen. The maintenance information indicates the following information:

- Error Log
- Warning Log
- Power-On Time
- Load Switching Frequency
- Muting Statistics Information

 Refer to *Safety Light Curtain Configuration Tool for Model F3SG (SD Manager 2) User's Manual* for more information on setting this function by the Configuration Tool.

2-23-2. Error Log

The user can view details of errors occurred in the past. The error information is recorded in the F3SG-RR main unit every 15 minutes. The displayed information is useful for troubleshooting. Up to 50 past errors can be recorded.

2-23-3. Warning Log

The user can view details of the following warnings occurred in the past. The warning information is recorded in the F3SG-RR main unit every 15 minutes. The displayed information can be used for troubleshooting. Up to 50 past warnings can be recorded.

- Muting sequence error
- Interlock sequence error
- Interference/vibration information

2-23-4. Power-ON Time

The user can view the power-on time of F3SG-RR. The power-on time information is recorded in the F3SG-RR main unit every 15 minutes. This information is useful to better understand when to schedule of F3SG-RR.

It is possible to give an output signal to the auxiliary output or indicate with Lamp (F39-LP and F39-BTLP, sold separately) when the power-on time threshold is exceeded. The excess power-on time information must be assigned to the output operation mode of the auxiliary output or Lamp.

 2-11. Auxiliary Output

 2-20. Lamp

The user can make changes to the settings by the Configuration Tool for the F3SG-RR.

Function	Factory Default Setting	Available Parameters
Power-on time threshold	30,000 h	30,000 to 1,000,000 h in 1-h increments/Disable

2-23-5. Load Switching Frequency

The user can view the number of switching operations of the load connected to F3SG-RR. The load switching frequency information is recorded in the F3SG-RR main unit every 15 minutes. This information is useful to understand the switching frequency of relays and contactors connected to F3SG-RR.

It is possible to give an output signal to the auxiliary output or indicate with Lamp (F39-LP and F39-BTLP, sold separately) when the switching frequency exceeds the switching frequency threshold. The excess load switching frequency information must be assigned to the output operation mode of the auxiliary output or Lamp.

 2-11. Auxiliary Output

 2-20. Lamp

The user can make changes to the settings by the Configuration Tool for the F3SG-RR.

Function	Factory Default Setting	Available Parameters
Load switching frequency threshold	100,000 times in 1-time increment	100,000 to 4,000,000 times in 1-time increments/Disable

2-23-6. Muting Statistics Information

This function logs and visualizes conditions of F3SG-RR muting operations to help the user adjust settings of muting input time difference. Also, its statistic calculation allows for optimal settings with reduced test runs.

 Refer to *Safety Light Curtain Configuration Tool for Model F3SG (SD Manager 2) User's Manual* for more information on setting this function by the Configuration Tool.

2-24. Operating Status Monitoring

2-24-1. Overview

I/O information and the state of F3SG-RR can be read out with the Configuration Tool. This function is only for F3SG-RR Configuration Tool.



Refer to *Safety Light Curtain Configuration Tool for Model F3SG (SD Manager 2) User's Manual* for more information on setting this function by the Configuration Tool.

2-24-2. Readout Information

The user can view the following information related to a receiver.

The information is displayed in a block in case of a cascade connection.

Information Name		Description
External wiring information	Power Supply	Displays a supply voltage being supplied
	OSSD 1 (Black)	Linked to safety output 1
	OSSD 2 (White)	Linked to safety output 2
	RESET (Red)	Linked to Reset/External Device Monitoring (EDM)/Override Input
	AUX (Yellow)	Linked to auxiliary output
	MUTE A (Gray) *	Linked to Muting input A
	MUTE B (Pink) *	Linked to Muting input B
Sensor Information	Scan code	Displays Scan Code setting
	EDM	Displays EDM setting
	Interlock/Pre-Reset	Displays Interlock/Pre-Reset setting
	Fixed/Floating Blanking	Displays Fixed/Floating Blanking setting
	PNP/NPN	Displays output mode (PNP/NPN) setting
Operating Status	Muting information	Linked to Muting state
	Override information	Linked to override state
	Sequence error information	Linked to Muting sequence error state or Interlock sequence error state
	Safety output information	Linked to safety output
	Blanking beam unblocked information	Linked to the state where the blanking beam is unblocked

* The MUTE A and MUTE B information is not displayed when using the Interface Unit (F39-GIF-1, sold separately). Use Bluetooth® Communication Unit (F39-BT and F39-BTLP, sold separately) to view the MUTE A and MUTE B information.

2-25. Setting Recovery

WARNING

The Setting Recovery function configurable with the Configuration Tool may increase risks. Make sure the Responsible Person conduct a thorough risk assessment analysis before managing and changing the settings. Unintended changes to the settings may cause a person to go undetected, resulting in serious injury.



2-25-1. Overview

You can use the Configuration Tool to recover the F3SG-RR setting to the default factory setting.



Refer to *Safety Light Curtain Configuration Tool for Model F3SG (SD Manager 2) User's Manual* for more information on setting this function by the Configuration Tool.

Chapter 3 Setting with Rotary Switch and End Cap

3-1. List of Features Configurable by Rotary Switch	100
3-2. Rotary Switch	101
3-3. List of Features Configurable by End Cap	102
3-4. End Cap	103

3-1. List of Features Configurable by Rotary Switch

For the F3SG-RR, the following function is configurable by the Rotary Switch.

Feature	Page
Scan Code Selection	p.20

3-2. Rotary Switch

⚠ DANGER

Make sure to test the operation of the F3SG-RR after setting with Rotary Switch to verify that the F3SG-RR operates as intended. Make sure to stop the machine until the test is complete. Unintended settings may cause a person to go undetected, resulting in serious injury or death.



F3SG-RR series has the Rotary Switches to configure functions near the power cable. Configure functions with the Rotary Switches before installing F3SG-RR in your site. Make sure to turn the power of the F3SG-RR on after the setting with the Rotary Switches is complete.

Cascaded sensors are operated based on the Rotary Switches setting of the primary sensor. The Rotary Switch setting of a secondary sensor does not affect the operation.

For F3SG-RR series, the following functional settings are available by the Rotary Switch on the emitter and receiver.

Function	Position	Description	Refer to
Scan Code Selection		Code A (factory default setting)	2-4
		Code B	2-4



- Operate the Rotary Switches before turning the power of the F3SG-RR on.
- Both the emitter and receiver units must be set to the same code.
- A change of the Rotary Switches setting is activated upon power-on or lockout reset.

CHECK! - If the Rotary Switch is operated during operation of the F3SG-RR, the F3SG-RR transitions to lockout.

3-3. List of Features Configurable by End Cap

For F3SG-RR series, the following functional setting is available by replacing the End Cap on the emitter with the supplied white End Cap.

Function	Page
External Test Input Selection	p.24

3-4. End Cap

⚠ DANGER

Make sure to test the operation of the F3SG-RR after setting with End Cap to verify that the F3SG-RR operates as intended. Make sure to stop the machine until the test is complete. Unintended settings may cause a person to go undetected, resulting in serious injury or death.



⚠ WARNING

When using the PNP output, connect the load between the output and 0 V line. When using the NPN output, connect the load between the output and +24 VDC line. Connecting the load between the output and a different power supply line from the above will result in a dangerous condition because the operation mode of safety output is reversed to "Dark-ON".



When using the PNP output, do not ground +24 VDC line. When using the NPN output, do not ground 0 V line. Otherwise, a ground fault may turn the safety output ON, resulting in a failure of stopping the machine.



F3SG-RR series has End Cap to configure the function at the opposite end from the power cable of the emitter. Configure the function before installing the F3SG-RR in your site. Make sure to turn the power off the F3SG-RR before replacing the End Cap.

For F3SG-RR series, the following functional setting is available by replacing the End Cap on the emitter.

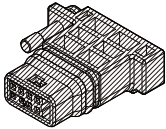
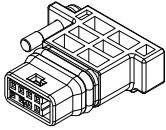
Function	End Cap	Description	Refer to
External Test Input Selection	 Black	24 V Active (factory default setting)	2-7
	 White	0 V Active	2-7



- The End Cap is not intended to be used for the receiver. Do not connect the End Cap to the receiver.
- Do not remove the insulating rubber attached to the End Cap. Failure to do so may cause deterioration of the protective functions.
- When attaching the End Cap, tightly fasten the screw (M2.5, recommended torque: 0.35N•m). Failure to do so may cause the End Cap to come loose, leading to deterioration of the protective functions.
- The insulating rubber attached to connector of the End Cap may come off when removing the End Cap. If the rubber comes off, place it back to the groove of the connector and insert the connector to the sensor body.

CHECK!

Chapter 4 Wiring/Installation

4-1. Installation Considerations	107
4-1-1. Detection Zone and Approach	107
4-1-2. Safety Distance	108
4-1-3. Distance from Reflective Surfaces	113
4-1-4. Mutual Interference Prevention	114
4-2. Cascade Connection	116
4-2-1. Overview	116
4-2-2. Connection Procedure	118
4-3. Dimensions	119
4-3-1. Mounted with Free-Location Brackets (F39-LGRA)	119
4-3-1-1. Backside Mounting	119
4-3-1-2. Side Mounting	120
4-3-1-3. Free-Location Bracket / Intermediate Bracket (F39-LGRA)	121
4-3-2. Mounted with Top/Bottom Brackets (F39-LGRTB) and Intermediate Bracket (F39-LGRA)	122
4-3-2-1. Backside Mounting	122
4-3-2-2. Side Mounting	123
4-3-2-3. Top/Bottom Bracket (F39-LGRTB)	124
4-3-3. Mounted with Top/Bottom Brackets (F39-LGRTB-2) and Intermediate Bracket (F39-LGRA)	125
4-3-3-1. Backside Mounting	125
4-3-3-2. Side Mounting	126
4-3-3-3. Top/Bottom Bracket (F39-LGRTB-2)	127
4-3-4. Mounted with Top/Bottom Brackets (F39-LGRTB-3) and Intermediate Bracket (F39-LGRA)	128
4-3-4-1. Backside Mounting	128
4-3-4-2. Side Mounting	129

4-3-4-3. Top/Bottom Bracket (F39-LGRTB-3)	130
4-3-5. Mounted with Top/Bottom Brackets (F39-LGRTB-□) and Accessories	131
4-3-5-1. Connected with Cascading Cable (F39-JGR2WTS)	131
4-3-5-2. Connected with Bluetooth® Communication Unit (F39-BT)	132
4-3-5-3. Connected with Lamp (F39-LP) or Lamp and Bluetooth® Communication Unit (F39-BTLP)	133
4-4. Mounting	134
4-4-1. Mounting Method	134
4-4-2. Number of Brackets Required	134
4-4-3. Mounting Procedure	135
4-4-3-1. Mounting with Free-Location Brackets (F39-LGRA)	135
4-4-3-2. Mounting with Top/Bottom Bracket (F39-LGRTB-□) and Intermediate Bracket (F39-LGRA)	138
4-4-4. Beam Alignment Procedure	143
4-5. Wiring	144
4-5-1. Wiring Precautions	144
4-5-2. Power Supply Unit	145
4-5-3. Cable Connections	146
4-5-3-1. Single-Ended Cable (Oil-Resistant Cable)	146
4-5-3-2. Single-Ended Cable	147
4-5-3-3. Double-Ended Cable	148
4-5-3-4. Cascading Cable	150
4-5-3-5. Reduced Wiring Connector System	151
4-5-3-6. Extending Cable Length with Commercially Available Cable	152
4-5-4. Functional Earth Connection	153

4-1. Installation Considerations

4-1-1. Detection Zone and Approach

⚠ WARNING

Install a protective structure so that the hazardous part of a machine can only be reached by passing through the sensor's detection zone. If access to the hazardous part by reaching over the detection zone of a vertically mounted F3SG-RR cannot be excluded, the height of the detection zone and the safety distance shall be determined in consideration of such a risk. Install the sensors so that part of the person is always present in the detection zone when working in a machine's hazardous zones. If a person is able to step into the hazardous zone of a machine and remain behind the F3SG-RR's detection zone, configure the system with Restart Interlock function. Failure to do so may result in serious injury due to unexpected startup.



Do not use this sensor for machines that cannot be stopped by electrical control. For example, do not use it for a pressing machine that uses a full-rotation clutch. Otherwise, the machine may not stop before a person reaches the hazardous part, resulting in serious injury.



To use the F3SG-RR in PSDI mode (Reinitiation of cyclic operation by the protective equipment), you must configure an appropriate circuit between the F3SG-RR and the machine. For details about PSDI, refer to OSHA1910.217, IEC61496-1, and other relevant standards and regulations.



Install the reset switch in a location that provides a clear view of the entire hazardous zone and where it cannot be activated from within the hazardous zone.



Do not use the F3SG-RR in environments where flammable or explosive gases are present. Doing so may cause an explosion.



The F3SG-RR cannot protect a person from an object flying from a hazardous zone. Install protective cover(s) or fence(s).



Correct installation

The hazardous zone of a machine can be reached only by passing through the sensor's detection zone.



While working, a person is inside the sensor's detection zone.



Safety distance reflects the possible access to the hazardous zone by reaching over the detection zone.

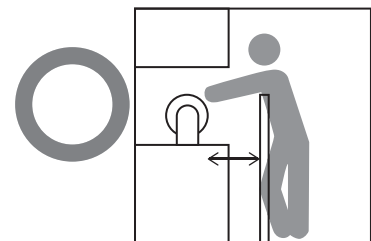

Incorrect installation

It is possible to reach the hazardous zone of a machine without passing through the sensor's detection zone.



A person is between the sensor's detection zone and the hazardous zone of a machine.



It is possible to access the hazardous zone by reaching over the detection zone.



4-1-2. Safety Distance

The safety distance is the distance that must be set between the F3SG-RR and a machine's hazardous part to stop the hazardous part before a person or object reaches it. The safety distance varies according to the standards of each country and the individual specifications of each machine. Always refer to the relevant standards.

⚠ WARNING

Make sure to secure the safety distance (S) between the F3SG-RR and the hazardous part. Otherwise, the machine may not stop before a person reaches the hazardous part, resulting in serious injury.



The response time of a machine is the time period from when the machine receives a stop signal to when the machine's hazardous part stops. Measure the response time on the actual system. Also, periodically check that the response time of the machine has not changed.

CHECK!

4-1-2-1. Safety Distance Formulas according to ISO 13855/EN ISO 13855

Detection Zone Orthogonal to Direction of Approach

$S = K \times T + C$. . . Formula (1)

- S: Safety distance
- K: Approach speed to the detection zone
- T: Total response time of the machine and F3SG-RR
- C: Additional distance calculated by the detection capability (or object resolution) of the F3SG-RR

Calculation Example for Systems with a Detection Capability of ≤ 40 mm

Use $K = 2,000$ mm/s and $C = 8 \times (d - 14$ mm) in formula (1) for the calculation.

$$S = 2,000 \text{ mm/s} \times (T_m + T_s) + 8 \times (d - 14 \text{ mm})$$

- S = Safety distance (mm)
- T_m = Machine's response time (s)
- T_s = Response time of the F3SG-RR from ON to OFF (s)
- d = Detection capability (or object resolution) of the F3SG-RR (mm)

[Calculation example]

When $T_m = 0.05$ s, $T_s = 0.008$ s, and $d = 14$ mm:

$$S = 2,000 \text{ mm/s} \times (0.05 \text{ s} + 0.008 \text{ s}) + 8 \times (14 \text{ mm} - 14 \text{ mm}) \\ = 116 \text{ mm} \dots \text{Formula (2)}$$

If the result < 100 mm, use $S = 100$ mm.

If the result exceeds 500 mm, use the following expression where $K = 1,600$ mm/s.

$$S = 1,600 \text{ mm/s} \times (T_m + T_s) + 8 \times (d - 14 \text{ mm}) \dots \text{Formula (3)}$$

If the result of this formula (3) < 500 mm, use $S = 500$ mm.

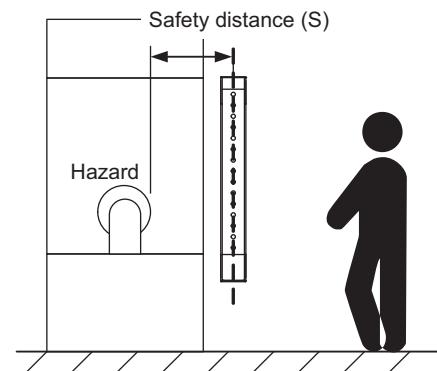

Calculation Example for Systems with Larger Detection Capability than 40 mm

Use $K = 1,600 \text{ mm/s}$ and $C = 850 \text{ mm}$ in formula (1) for calculation.

$$S = 1,600 \text{ mm/s} \times (T_m + T_s) + 850 \dots \text{Formula (4)}$$

- S = Safety distance (mm)
- T_m = Machine's response time (s)
- T_s = Response time of the F3SG-RR from ON to OFF (s)

[Calculation example]

When $T_m = 0.05 \text{ s}$ and $T_s = 0.008 \text{ s}$:

$$\begin{aligned} S &= 1,600 \text{ mm/s} \times (0.05 \text{ s} + 0.008 \text{ s}) + 850 \text{ mm} \\ &= 942.8 \text{ mm} \end{aligned}$$

Possible Circumventing by Reaching Over the Detection Zone

If access to the hazardous zone by reaching over the detection zone of vertically mounted F3SG-RR cannot be excluded, the height and the safety distance, S , of the F3SG-RR shall be determined. S shall be determined by comparison of the calculated values in *Detection Zone Orthogonal to Direction of Approach*. The greater value resulting from this comparison shall be applied.

$$S = (K \times T) + C_{ro} \dots \text{Formula (5)}$$

- S : Safety distance
- K : Approach speed to the detection zone
- T : Total response time of the machine and F3SG-RR
- C_{ro} : Approach distance based on the distance which personnel can move towards the hazardous zone of a machine by reaching over the detection zone. The distance is determined in the table below based on the height of the hazardous zone, a , and the height of the upper edge of the detection zone, b .

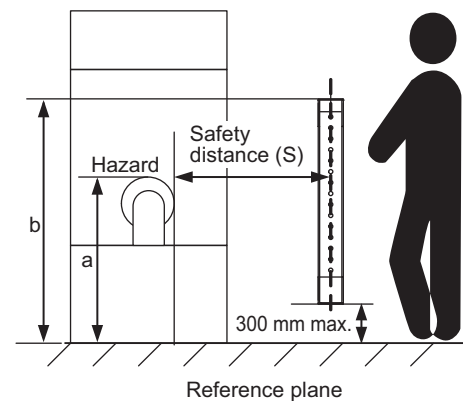

Note: Lower edge of the detection zone above 300 mm in relation to the reference plane does not offer sufficient protection against crawling below.

First, use $K = 2,000 \text{ mm/s}$ in formula (5) for the calculation. If the result of this calculation is less than 100 mm, use $S = 100 \text{ mm}$.

If the result exceeds 500 mm, use $K = 1,600 \text{ mm/s}$ to recalculate it. If the result of the recalculation is less than 500 mm, use $S = 500 \text{ mm}$.

Height of hazardous zone, a	Height of upper edge of detection zone, b											
	900	1000	1100	1200	1300	1400	1600	1800	2000	2200	2400	2600
	Additional distance to hazardous zone, Cro											
2600	0	0	0	0	0	0	0	0	0	0	0	0
2500	400	400	350	300	300	300	300	300	250	150	100	0
2400	550	550	550	500	450	450	400	400	300	250	100	0
2200	800	750	750	700	650	650	600	550	400	250	0	0
2000	950	950	850	850	800	750	700	550	400	0	0	0
1800	1100	1100	950	950	850	800	750	550	0	0	0	0
1600	1150	1150	1100	1000	900	850	750	450	0	0	0	0
1400	1200	1200	1100	1000	900	850	650	0	0	0	0	0
1200	1200	1200	1100	1000	850	800	0	0	0	0	0	0
1000	1200	1150	1050	950	750	700	0	0	0	0	0	0
800	1150	1050	950	800	500	450	0	0	0	0	0	0
600	1050	950	750	550	0	0	0	0	0	0	0	0
400	900	700	0	0	0	0	0	0	0	0	0	0
200	600	0	0	0	0	0	0	0	0	0	0	0
0	0	0	0	0	0	0	0	0	0	0	0	0

Note 1. Upper edge of the detection zone below 900 mm is not included since they do not offer sufficient protection against circumventing or stepping over.

Note 2. When determining the values of this table, it shall not be interpolated. If the known values a, b or Cro are between two values of this table, the greater safety distance shall be used.

[Calculation example]

- T: $T_m + T_s$ (s)
- T_m : Machine's response time (s)
- T_s : Response time of the F3SG-RR from ON to OFF (s)
- a: Height of machine hazardous zone (mm)
- b: Height of upper edge of detection zone (mm)

When $T_m = 0.05$ s, $T_s = 0.008$ s, $a = 1,400$ mm, $b = 1,500$ mm:

From the table above, $C_{ro} = 850$ mm. Since b is between 1,400 mm and 1,600 mm, $b = 1,400$ mm which has the greater C_{ro} value, shall be used.

$$S = 2,000 \text{ mm/s} \times (0.05 \text{ s} + 0.008 \text{ s}) + 850 \text{ mm} \\ = 966 \text{ mm}$$

Since 966 mm is greater than 500 mm, use $K = 1,600$ mm/s and recalculate it.

$$S = 1,600 \text{ m/s} \times (0.05 \text{ s} + 0.008 \text{ s}) + 850 \text{ mm} \\ = 942.8 \text{ mm}$$

Since $S = 942.8$ mm is greater than $S = 116$ mm calculated by the calculation example of *Detection Zone Orthogonal to Direction of Approach*, the required safety distance S is 942.8 mm.

 Refer to *Detection Zone Orthogonal to Direction of Approach* under 4-1-2-1. *Safety Distance Formulas according to ISO 13855/EN ISO 13855.*

Detection Zone Parallel to Direction of Approach

Use $K = 1,600 \text{ mm/s}$ and $C = (1200 - 0.4 \times H)$ in formula (1) for calculation. Note that C must not be less than 850 mm.

$$S = 1,600 \text{ mm/s} \times (T_m + T_s) + 1200 - 0.4 \times H$$

- S = Safety distance (mm)
- T_m = Machine's response time (s)
- T_s = Response time of F3SG-RR from ON to OFF (s)
- H = Installation height (mm)

Note that H must satisfy:

$$1000 \geq H \geq 15 \quad (d - 50 \text{ mm}) \geq 0 \text{ mm}$$

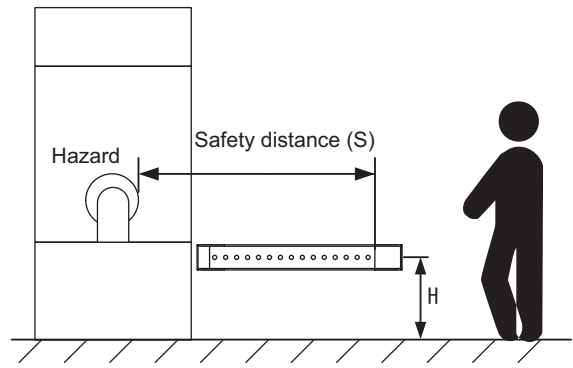

Also, you must include a hazardous condition under which a person may go through under a detection zone if H exceeds 300 mm (200 mm for other purpose than industrial use) into risk assessment.

[Calculation example]

When $T_m = 0.05 \text{ s}$, $T_s = 0.008 \text{ s}$, and $d = 14 \text{ mm}$:

$$S = 1,600 \text{ mm/s} \times (0.05 \text{ s} + 0.008 \text{ s}) + 1200 - 0.4 \times 500 \text{ mm} = 1092.8 \text{ mm}$$

When a warning zone is configured as in the figure, you must calculate L , a distance from an end of casing to a detection zone, using a formula below:

$$L = (\text{Total number of F3SG-RR beams} - \text{number of warning zone beams} - 1) \times P + 10$$

- P : Beam Gap (mm)
 F3SG-4RR□□□□-14 . . . 10 mm
 F3SG-4RR□□□□-25 . . . 20 mm

Refer to 1-6-1. List of Models/Response Time/Current Consumption/Weight for total number of F3SG-RR beams.

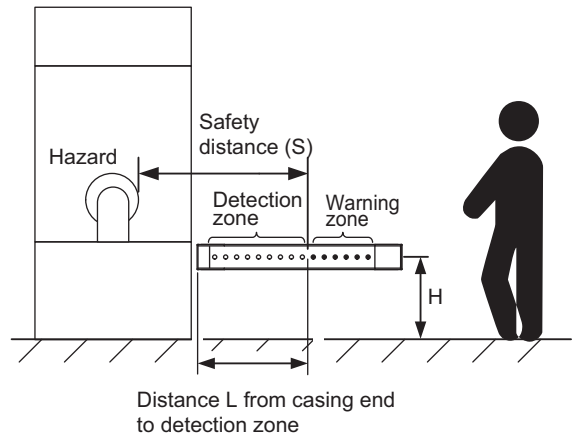

4-1-2-2. Safety Distance Formulas according to ANSI B11.19

If a person approaches the detection zone of the F3SG-RR orthogonally, calculate the safety distance as shown below.

$$S = K \times (T_s + T_c + T_r + T_{bm}) + D_{pf}$$

- S: Safety distance
- K: Approach speed to the detection zone (the value recommended by OSHA standard is 1,600 mm/s)

Approach speed K is not specified in the ANSI B.11.19 standard. To determine the value of K to apply, consider all factors, including the operator's physical ability.

- T_s = Machine's stopping time (s)
- T_r = Response time of the F3SG-RR from ON to OFF (s)
- T_c = Machine control circuit's maximum response time required to activate its brake (s)
- T_{bm} = Additional time (s)

If a machine has a brake monitor, " T_{bm} = Brake monitor setting time - ($T_s + T_c$)". If it has no brake monitor, we recommend using 20% or more of ($T_s + T_c$) as additional time.

- D_{pf} = Additional distance

According to ANSI's formula, D_{pf} is calculated as shown below:

$D_{pf} = 3.4 \times (d - 7.0)$: Where d is the detection capability (or object resolution) of the F3SG-RR (unit: mm)

[Calculation example]

When $K = 1,600$ mm/s, $T_s + T_c = 0.06$ s, brake monitor setting time = 0.1 s,

$T_r = 0.008$ s, and $d = 14$ mm:

$$T_{bm} = 0.1 - 0.06 = 0.04 \text{ s}$$

$$D_{pf} = 3.4 \times (14 - 7.0) = 23.8 \text{ mm}$$

$$S = 1,600 \times (0.06 + 0.008 + 0.04) + 23.8 = 196.6 \text{ mm}$$

4-1-3. Distance from Reflective Surfaces

⚠ WARNING

Install the sensor system so that it is not affected by reflective surfaces. Failure to do so may hinder detection, resulting in serious injury.



4-1-3-1. F3SG-4RR (Type 4 ESPE)

Install the sensor system at distance D or further from highly reflective surfaces such as metallic walls, floors, ceilings, or workpieces, as shown below.

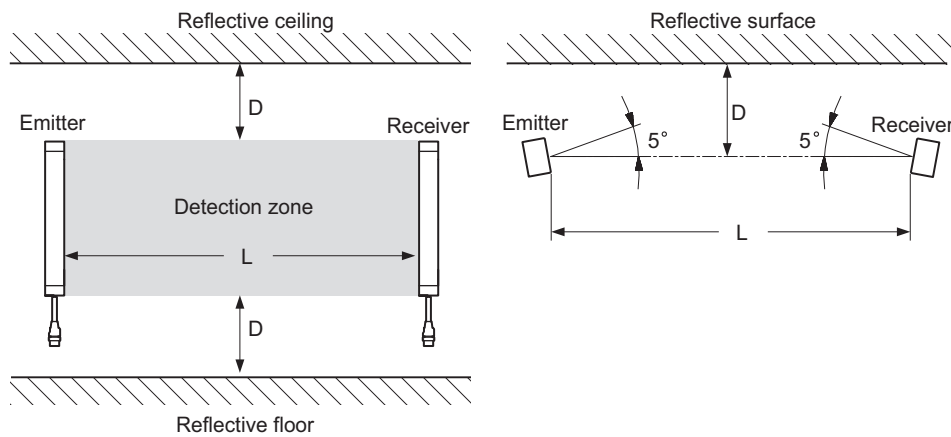

Distance between an emitter and a receiver (operating range L)	Allowable installation distance D
0.3 to less than 3 m	0.13 m
3 m or more	$L/2 \times \tan 5^\circ = L \times 0.044 \text{ m}$

4-1-4. Mutual Interference Prevention

⚠ WARNING

Do not use the sensor system with mirrors in a retro-reflective configuration. Doing so may hinder detection. It is possible to use mirrors to alter the detection zone to a 90-degree angle. 

When using more than 1 set of F3SG-RR in adjacent areas, the emitter of one F3SG-RR may interfere with the receiver of the other, causing the safety functions to stop working properly. Install and configure them so that mutual interference does not occur. 

When two or more F3SG-RR systems are mounted in close proximity to each other, precautions should be taken to avoid one system interfering with another, such as by back-to-back configuration, physical barrier, Scan Code Selection and adjustment of distance between adjacent sensors.

■ Example

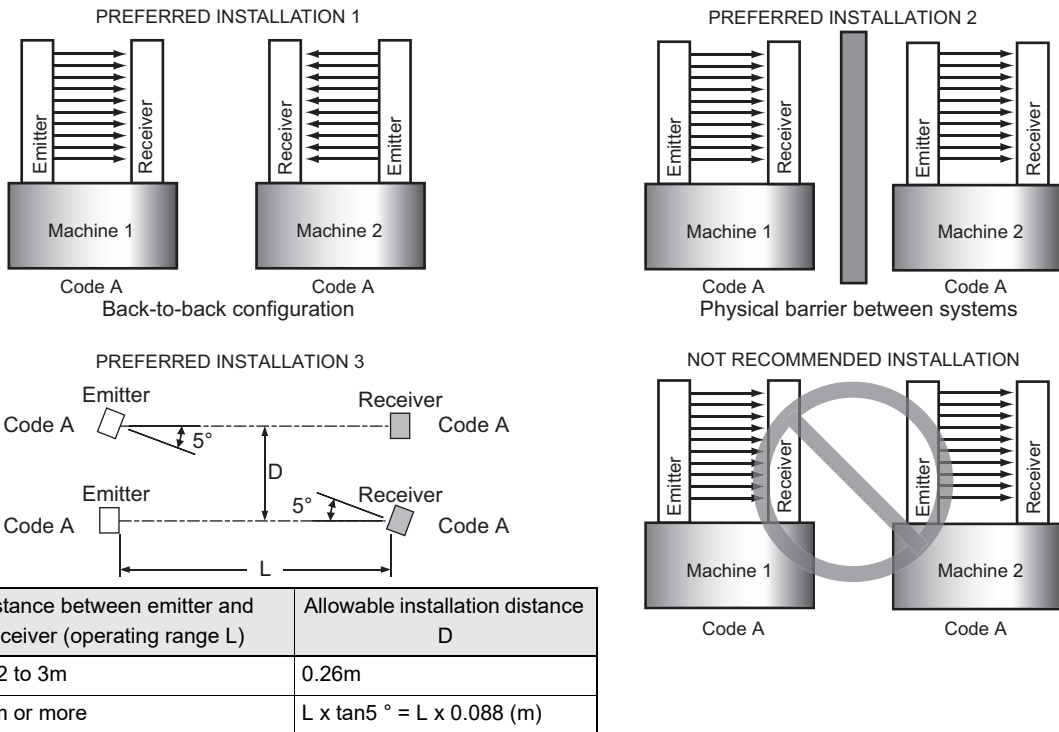

The scan code feature of the F3SG-RR system allows for placement of systems in close proximity and in line with each other. The distinctive coding of the beams provide for unique operation of a system while in view of another system with a different scan code. Two unique codes are available on the F3SG-RR.

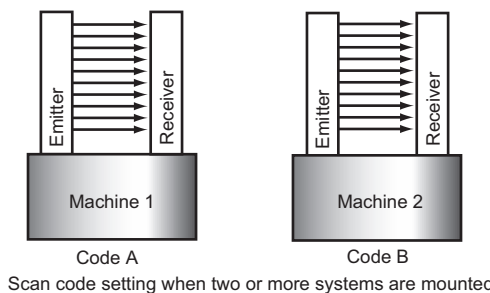

The emitter and receiver units must be set to the same scan code for the receiver to enter the Machine Run state. The scan code is selectable by the Rotary Switch on the emitter and receiver units.

 Refer to 2-4. *Scan Code Selection* for more information on the scan code feature.

 Refer to 3-2. *Rotary Switch* for more information on setting the scan code by the Rotary Switch.

4-2. Cascade Connection

4-2-1. Overview

Up to 3 sets of F3SG-RR can be series-connected. Cascade connection allows them to be used as a safety light curtain, requiring only 1 set to be wired to a controller and preventing mutual interference. If any 1 set of series-connected F3SG-RR is blocked, both of the safety outputs turn OFF.

- Number of connections: Up to 3 sets
- Total number of beams: Up to 255 beams
- Response time: Varies according to the number of beams of cascaded F3SG-RR segments.
- Cable length between sensors: Up to 10 m (not including cascading cable (F39-JGR2WTS) and power cable)

 1-6-2. Calculation of Response Time of Cascaded Segments

Example: Configuring an U-shaped detection zone

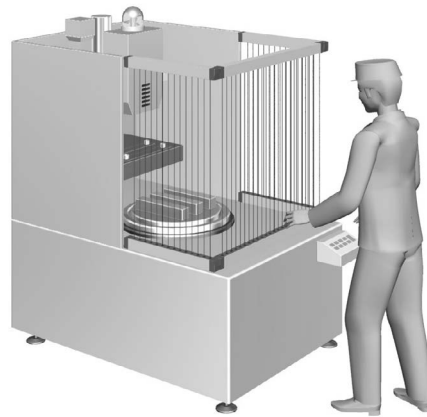

The sensor segments in a cascade connection are called as follows:

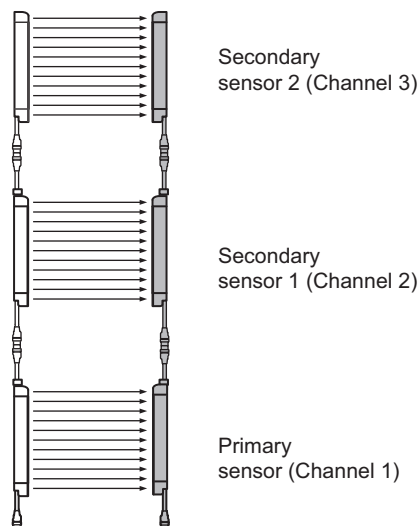

Properly connect an emitter to another emitter, and a receiver to another receiver, as shown below.

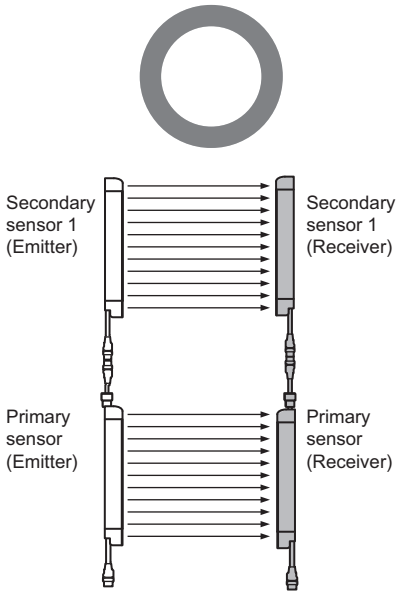

Do not series-connect an emitter and receiver. They will enter lockout state.

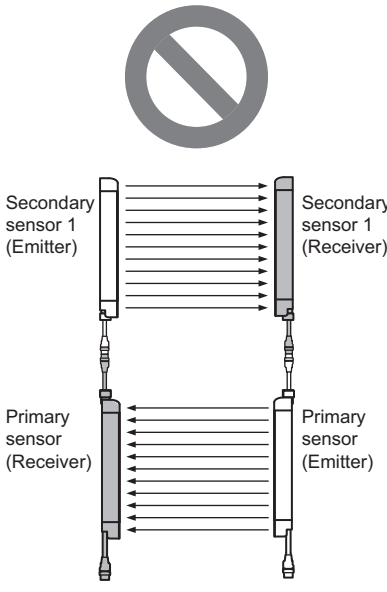

Do not face different models of emitters and receivers toward each other. They will enter lockout state or will be unable to detect objects.

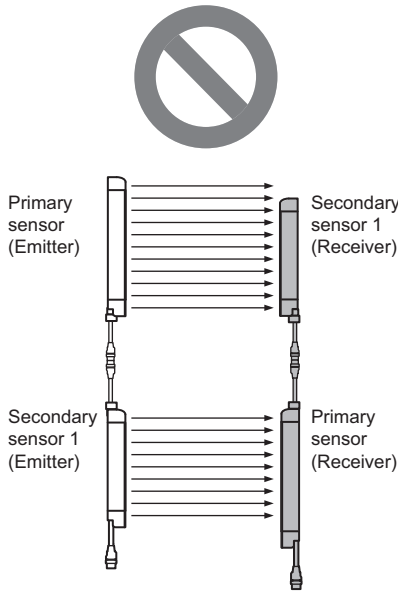

If caps and Cascading Cables are not connected properly, the F3SG-RR enters lockout (when power is turned ON).

CHECK!

4-2-2. Connection Procedure

1. Remove the caps from the primary sensor. Loosen the screw (M2.5 cross-shaped) to remove the cap.
2. Connect the the the primary sensor and the secondary sensor with the F39-JGR2WTS Cascading Cable (sold separately).
3. If the length of the Cascading Cable is insufficient, connect the F39-JD□B-□ Double-Ended Cable (sold separately) between the Cascading Cable and the power cable of the secondary sensor, as required. (Cable length between sensors: 10 m max. (not including cascading cable (F39-JGR2WTS) and power cable))

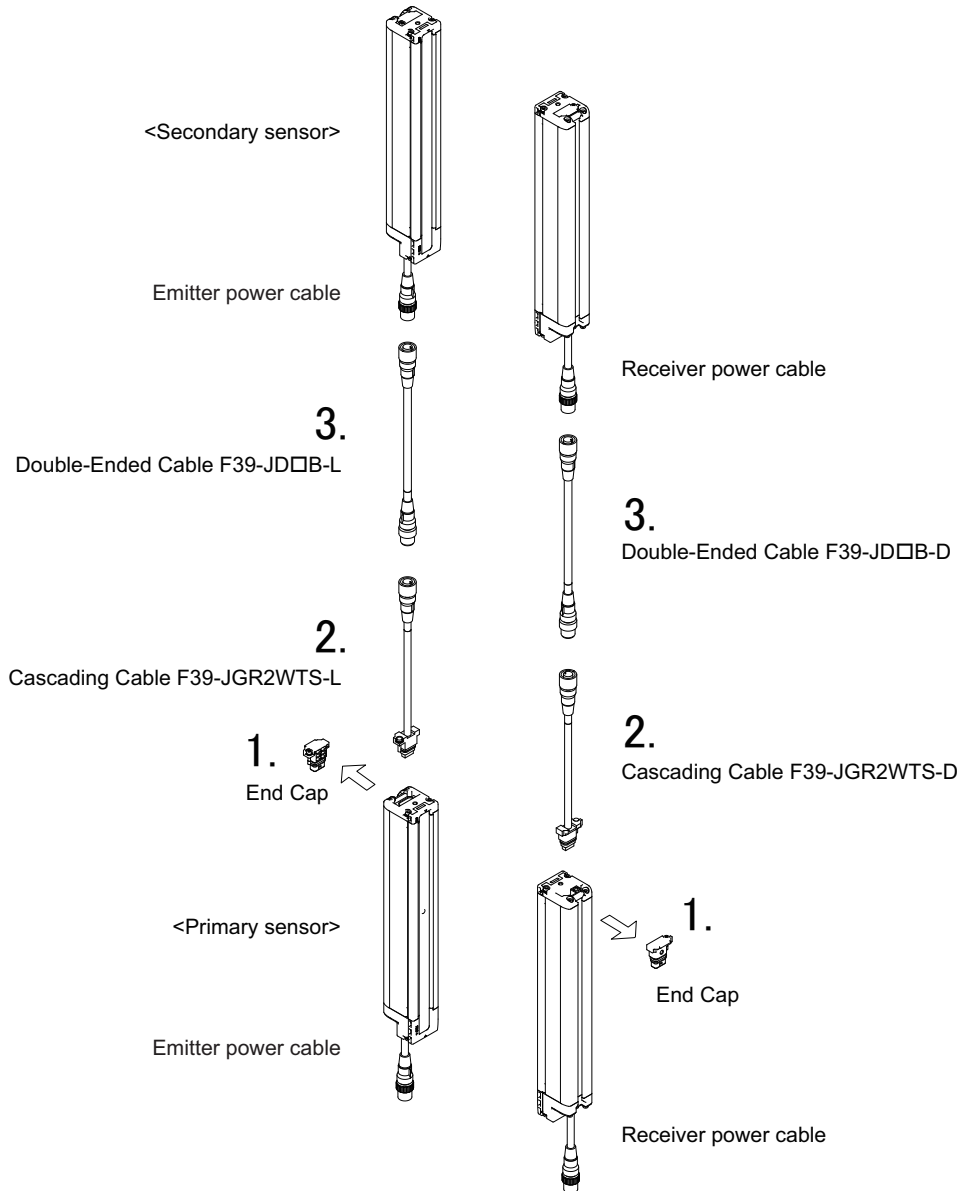

CHECK!

- When attaching a cable or cap, securely fasten the screws (M2.5, recommended torque: 0.35 N·m). Failure to do so may cause the cable/cap to come loose, leading to deterioration of the protective functions.
- Attaching/detaching of the cap and the Cascading Cable may cause misalignment of rubber grommet in the connector assembly. Press the grommet to the bottom of the connector and attach the connector to the sensor again.

4-3. Dimensions

4-3-1. Mounted with Free-Location Brackets (F39-LGRA)

4-3-1-1. Backside Mounting

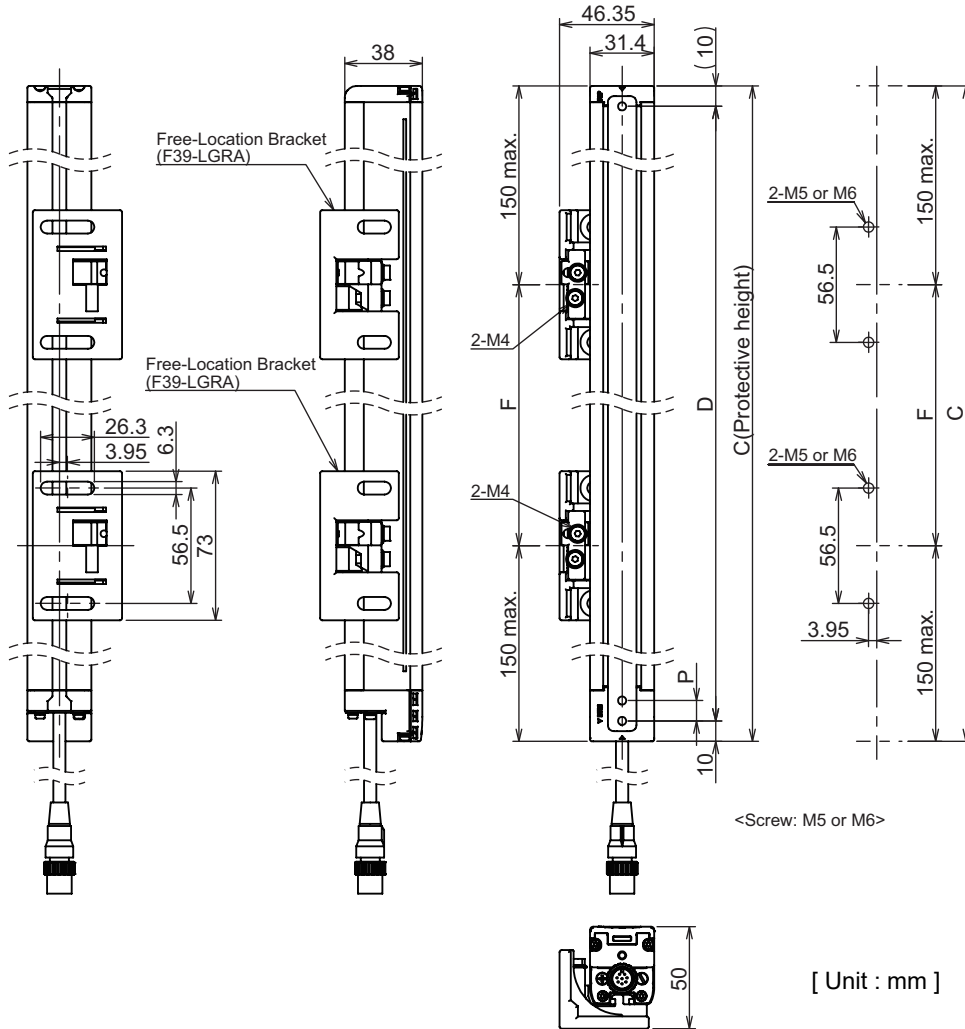

Dimension C	4-digit number of the type name (Protective height)	
Dimension D	C-20	
Dimension P	F3SG-4RR□□□□-14	10
	F3SG-4RR□□□□-25	20

Protective height (C)	Number of Free-Location Brackets *1	Dimension F
0240 to 1200	2 *2	1000 mm max.
1280 to 1920	3	1000 mm max.

*1. The number of brackets required to mount either one of emitter and receiver.

*2. Mounting an emitter or receiver with one bracket is possible for the model of protective height of 0240. In this case, locate this bracket at half the Dimension C (or at the center of the sensor length).

4-4-3-1. Mounting with Free-Location Brackets (F39-LGRA)

- Use the brackets of specified quantities and locations according to the dimensions. The other brackets than described above may not meet the specified ratings and performance.
- CHECK!** - When you use the sensor in a situation where the sensor is under a load, increase the number of the brackets used.
- This bracket allows beam alignment after fixing the bracket to a wall surface. The angle adjustment range of the bracket is $\pm 15^\circ$.

4-3-1-2. Side Mounting

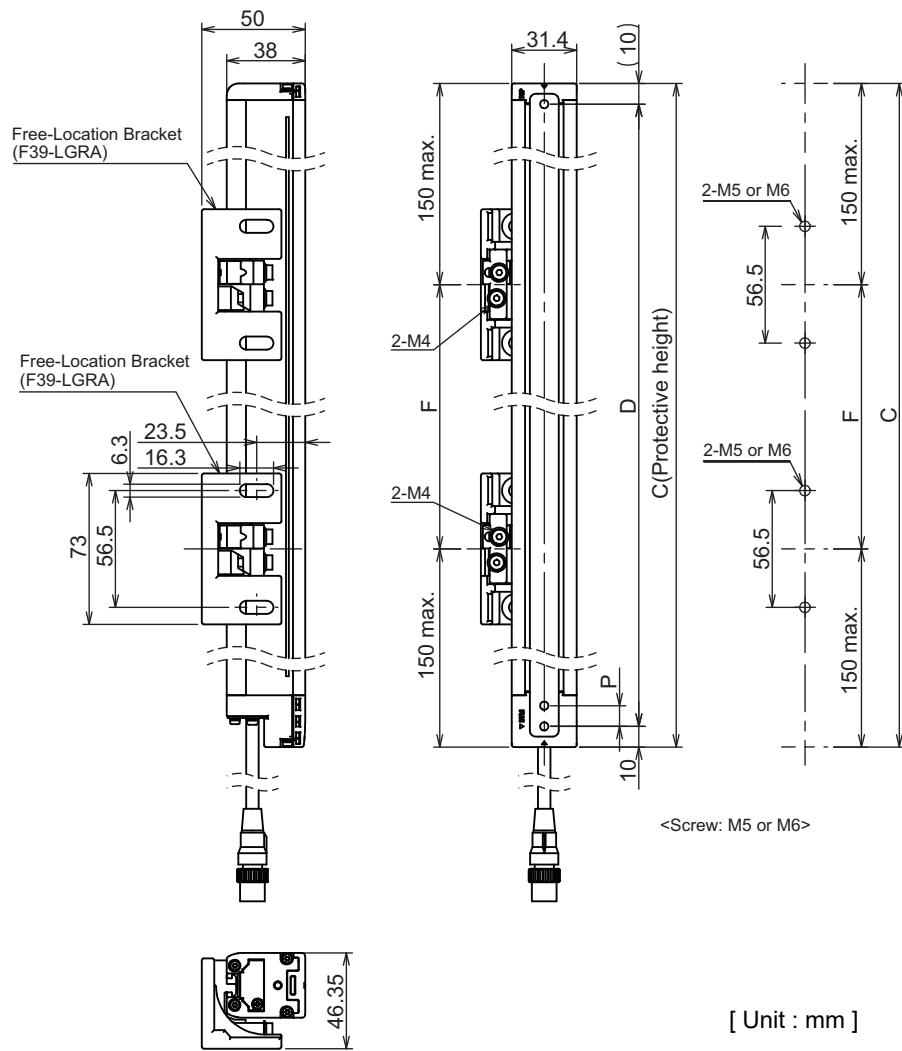

Dimension C	4-digit number of the type name (Protective height)	
Dimension D	C-20	
Dimension P	F3SG-4RR□□□□-14	10
	F3SG-4RR□□□□-25	20

Protective height (C)	Number of Free-Location Brackets *1	Dimension F
0240 to 1200	2 *2	1000 mm max.
1280 to 1920	3	1000 mm max.

*1. The number of brackets required to mount either one of emitter and receiver.
 *2. Mounting an emitter or receiver with one bracket is possible for the model of protective height of 0240. In this case, locate this bracket at half the Dimension C (or at the center of the sensor length).

4-4-3-1. Mounting with Free-Location Brackets (F39-LGRA)

- Use the brackets of specified quantities and locations according to the dimensions. The other brackets than described above may not meet the specified ratings and performance.
- CHECK!** - When you use the sensor in a situation where the sensor is under a load, increase the number of the brackets used.
- This bracket allows beam alignment after fixing the bracket to a wall surface. The angle adjustment range of the bracket is ±15°.

4-3-1-3. Free-Location Bracket / Intermediate Bracket (F39-LGRA)

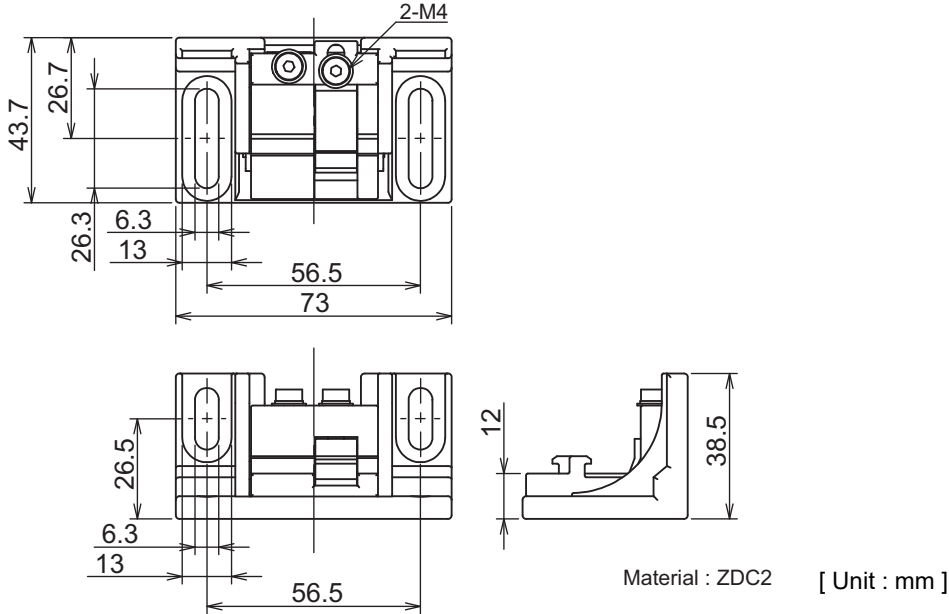

4-3-2-2. Side Mounting

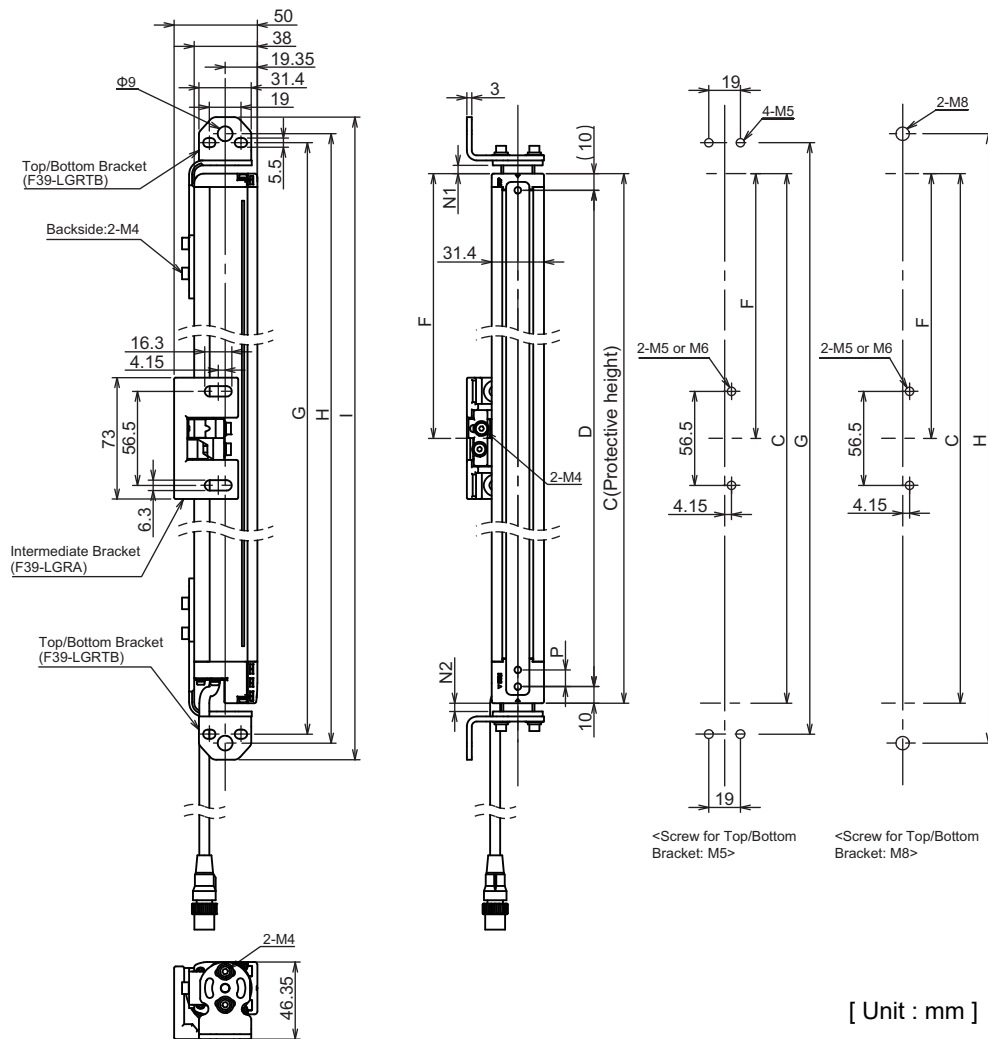

Dimension C	4-digit number of the type name (Protective height)	
Dimension D	C-20	
Dimension G	C+27.2+N1+N2	
Dimension H	C+38+N1+N2	
Dimension I	C+58+N1+N2	
Dimension N1	0 to 30	
Dimension N2	0 to 13	
Dimension P	F3SG-4RR□□□□-14	10
	F3SG-4RR□□□□-25	20

Protective height (C)	Number of Top/Bottom Brackets *	Number of Intermediate Brackets *	Dimension F
0240 to 1040	2	0	-
1120 to 1920	2	1	1000 mm max.

*The number of brackets required to mount either one of emitter and receiver.



4-4-3-2. Mounting with Top/Bottom Bracket (F39-LGRTB-□) and Intermediate Bracket (F39-LGRA)



- Use the brackets of specified quantities and locations according to the dimensions. The other brackets than described above may not meet the specified ratings and performance.
- When you use the sensor in a situation where the sensor is under a load, increase the number of the brackets used.

CHECK!

- This bracket allows beam alignment after fixing the bracket to a wall surface.
- The angle adjustment range is $\pm 22.5^\circ$ when using the Top/Bottom Brackets only. The angle adjustment range is $\pm 15^\circ$ when using the Top/Bottom Brackets and Intermediate Bracket together.

4-3-2-3. Top/Bottom Bracket (F39-LGRTB)

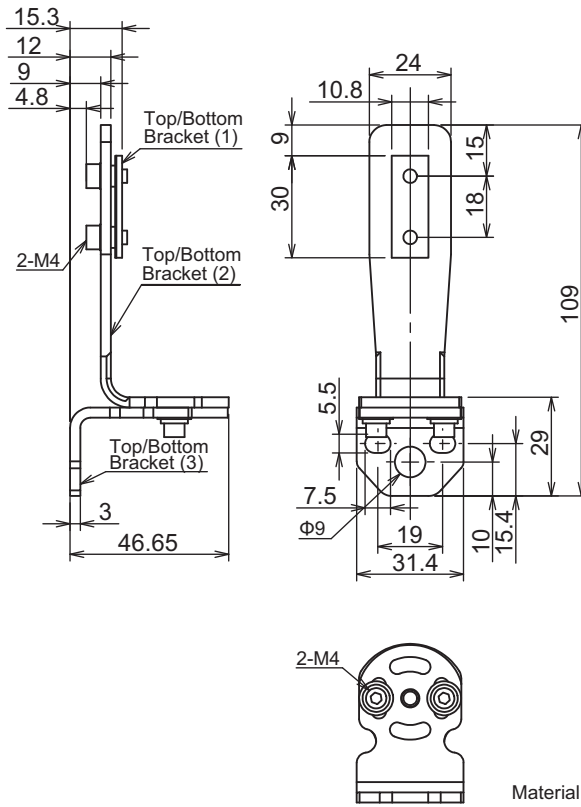

Material: SUS304 [Unit : mm]

4-3-3. Mounted with Top/Bottom Brackets (F39-LGRTB-2) and Intermediate Bracket (F39-LGRA)

4-3-3-1. Backside Mounting

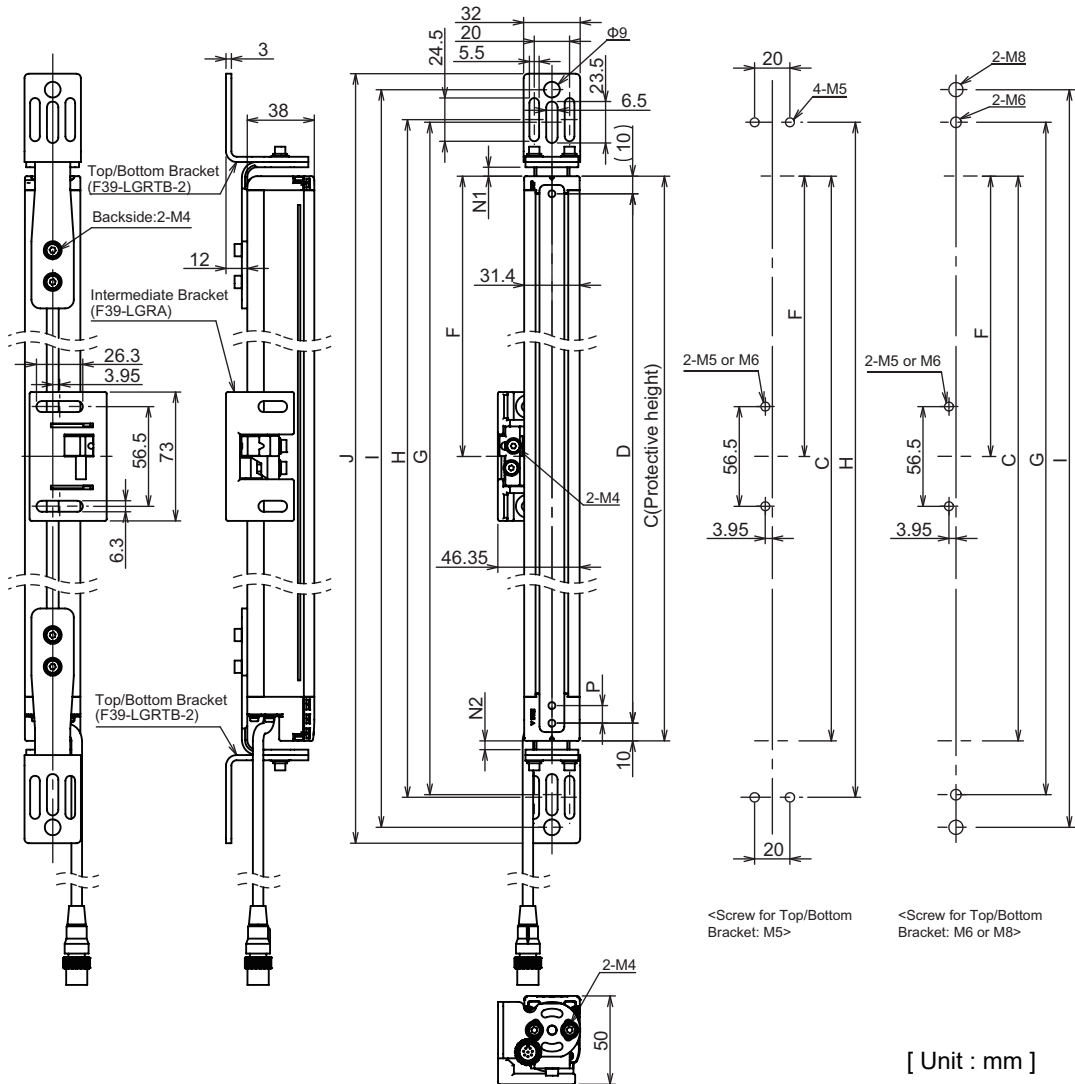

<Screw for Top/Bottom Bracket: M5>
<Screw for Top/Bottom Bracket: M6 or M8>

[Unit : mm]

Dimension C	4-digit number of the type name (Protective height)	
Dimension D	C-20	
Dimension G	C+51+N1+N2	
Dimension H	C+54+N1+N2	
Dimension I	C+88+N1+N2	
Dimension J	C+106+N1+N2	
Dimension N1	0 to 30	
Dimension N2	0 to 13	
Dimension P	F3SG-4RR□□□□-14	10
	F3SG-4RR□□□□-25	20

Protective height (C)	Number of Top/Bottom Brackets *	Number of Intermediate Brackets *	Dimension F
0240 to 1040	2	0	-
1120 to 1920	2	1	1000 mm max.

*The number of brackets required to mount either one of emitter and receiver.

4-4-3-2. Mounting with Top/Bottom Bracket (F39-LGRTB-□) and Intermediate Bracket (F39-LGRA)

- Use the brackets of specified quantities and locations according to the dimensions. The other brackets than described above may not meet the specified ratings and performance.
 - When you use the sensor in a situation where the sensor is under a load, increase the number of the brackets used.
- CHECK! - This bracket allows beam alignment after fixing the bracket to a wall surface.
- The angle adjustment range is $\pm 22.5^\circ$ when using the Top/Bottom Brackets only. The angle adjustment range is $\pm 15^\circ$ when using the Top/Bottom Brackets and Intermediate Bracket together.

4-3-3-3. Top/Bottom Bracket (F39-LGRTB-2)

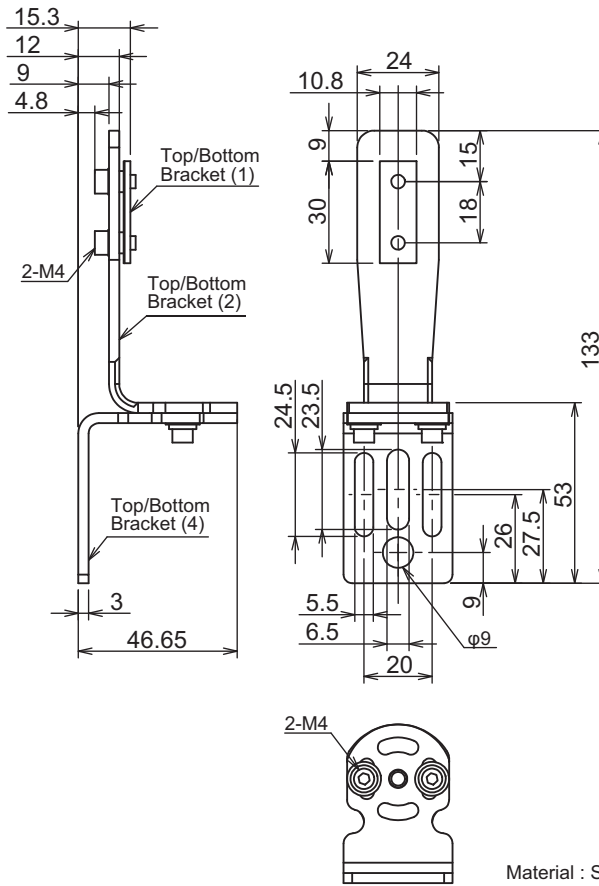

4-3-4-2. Side Mounting

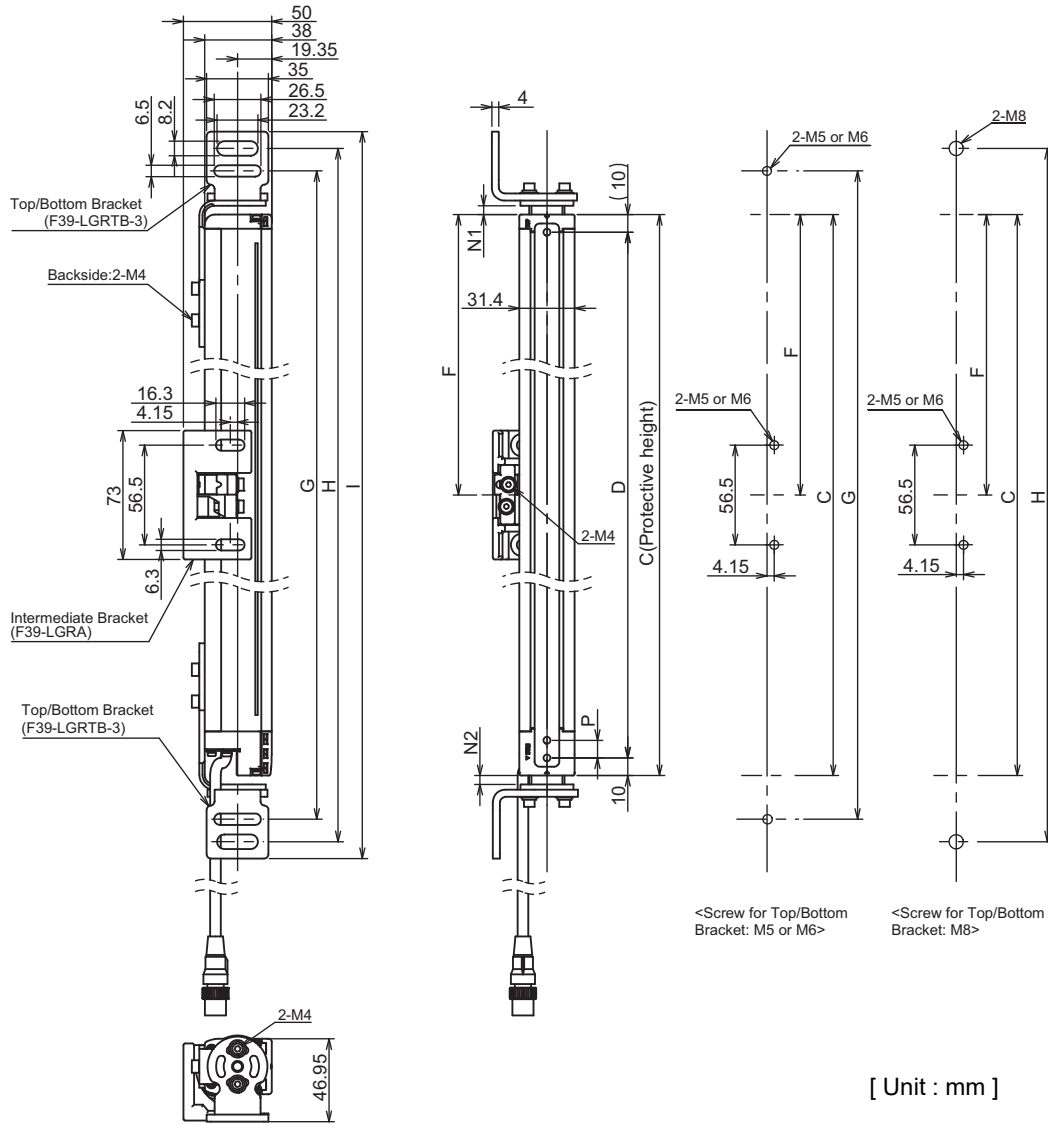

Dimension C	4-digit number of the type name (Protective height)	
Dimension D	C-20	
Dimension G	$C+39.5+N1+N2$	
Dimension H	$C+65+N1+N2$	
Dimension I	$C+84+N1+N2$	
Dimension N1	0 to 30	
Dimension N2	0 to 13	
Dimension P	F3SG-4RR□□□□-14	10
	F3SG-4RR□□□□-25	20

Protective height (C)	Number of Top/Bottom Brackets *	Number of Intermediate Brackets *	Dimension F
0240 to 1040	2	0	-
1120 to 1920	2	1	1000 mm max.

*The number of brackets required to mount either one of emitter and receiver.

4-4-3-2. Mounting with Top/Bottom Bracket (F39-LGRTB-□) and Intermediate Bracket (F39-LGRA)

- Use the brackets of specified quantities and locations according to the dimensions. The other brackets than described above may not meet the specified ratings and performance.
- When you use the sensor in a situation where the sensor is under a load, increase the number of the brackets used.
- CHECK!** - This bracket allows beam alignment after fixing the bracket to a wall surface.
- The angle adjustment range is $\pm 22.5^\circ$ when using the Top/Bottom Brackets only. The angle adjustment range is $\pm 15^\circ$ when using the Top/Bottom Brackets and Intermediate Bracket together.

4-3-4-3. Top/Bottom Bracket (F39-LGRTB-3)

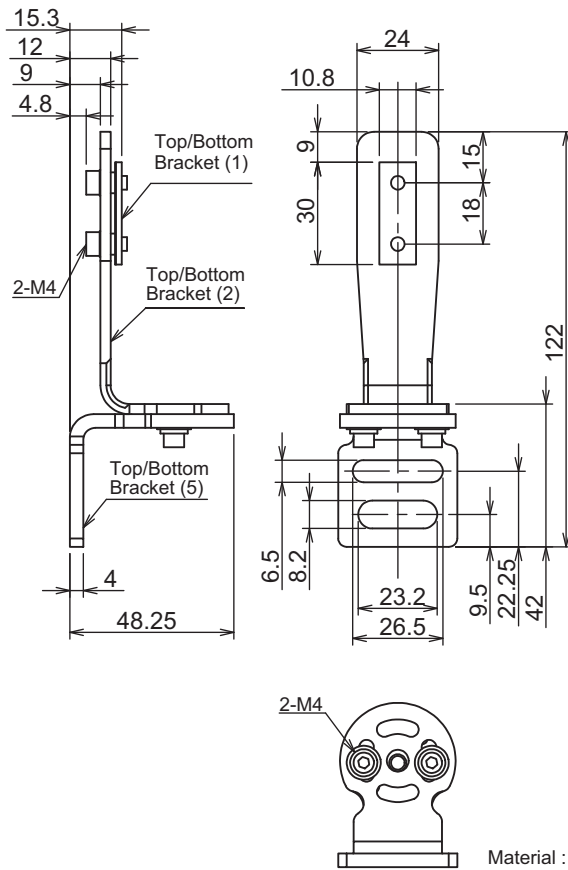

Material : SUS304

[Unit : mm]

4-3-5. Mounted with Top/Bottom Brackets (F39-LGRTB-□) and Accessories

4-3-5-1. Connected with Cascading Cable (F39-JGR2WTS)

[Top/Bottom Brackets (F39-LGRTB)]

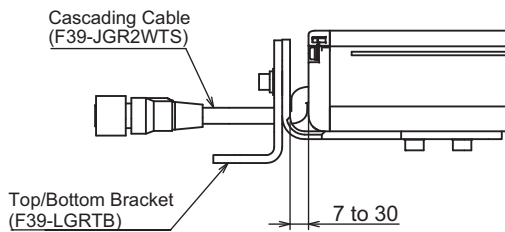
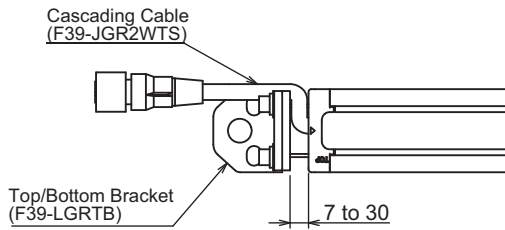

[Top/Bottom Brackets (F39-LGRTB-2)]

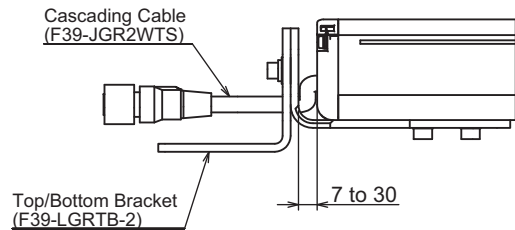
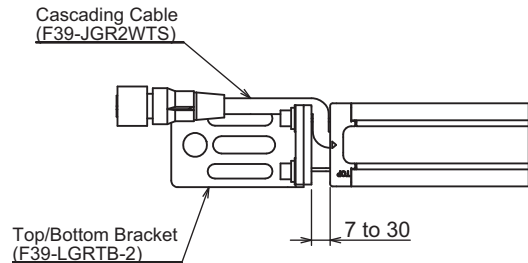

[Unit : mm]

[Top/Bottom Brackets (F39-LGRTB-3)]

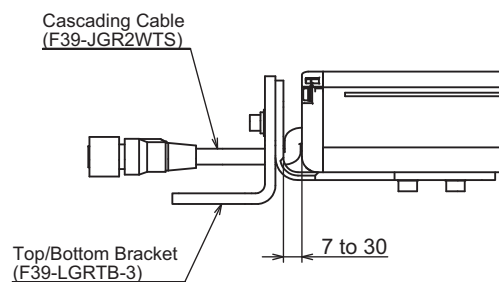
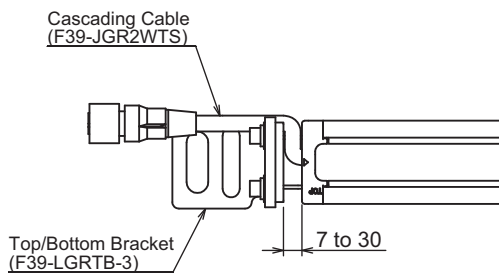

[Unit : mm]



The F3SG-RR meets IP67* (IEC 60529) when it is correctly connected with the F39-JGR2WTS Cascading Cable.

*When the accessory is used, protect it from cutting oil.

CHECK!

4-3-5-2. Connected with Bluetooth® Communication Unit (F39-BT)

[Top/Bottom Brackets (F39-LGRTB)]
Receiver

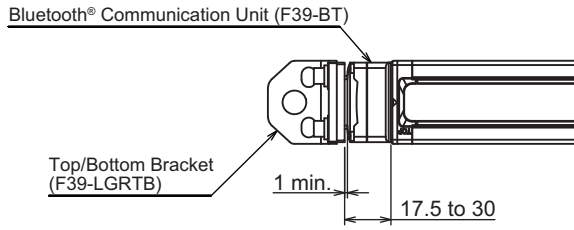

[Top/Bottom Brackets (F39-LGRTB-2)]
Receiver

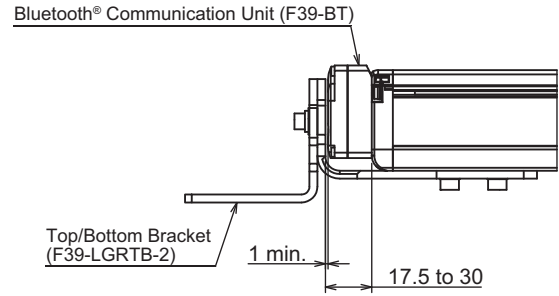
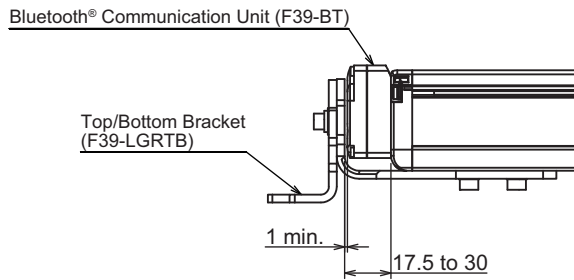
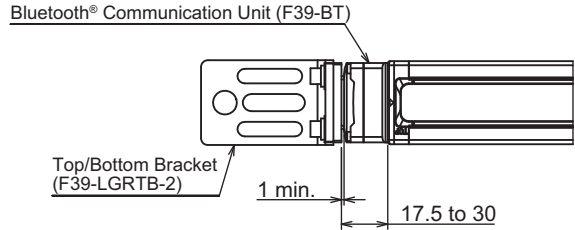

[Unit : mm]

[Top/Bottom Brackets (F39-LGRTB-3)]
Receiver

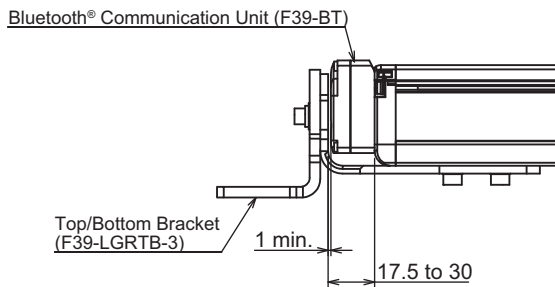
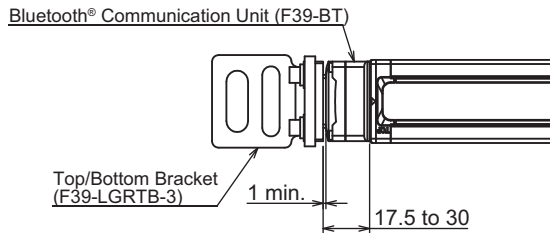

[Unit : mm]

[Unit : mm]



CHECK!

- Make sure to connect the F39-BT Bluetooth® Communication Unit to the receiver.
- The F3SG-RR meets IP67* (IEC 60529) when it is correctly connected with the F39-BT Bluetooth® Communication Unit.

*When the accessory is used, protect it from cutting oil.

4-3-5-3. Connected with Lamp (F39-LP) or Lamp and Bluetooth® Communication Unit (F39-BTLP)

[Top/Bottom Brackets (F39-LGRTB)]
Receiver

Lamp (F39-LP) /
Lamp and Bluetooth® Communication Unit (F39-BTLP)

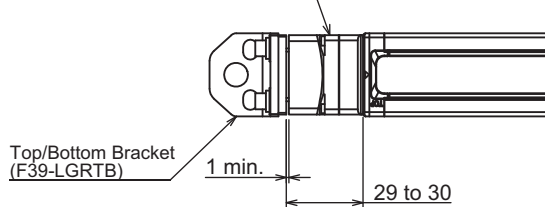

Lamp (F39-LP) /
Lamp and Bluetooth® Communication Unit (F39-BTLP)

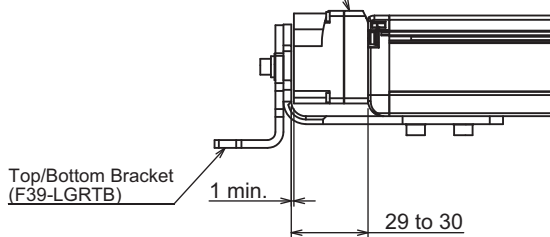

[Top/Bottom Brackets (F39-LGRTB-2)]
Receiver

Lamp(F39-LP)/
Lamp and Bluetooth® Communication Unit (F39-BTLP)

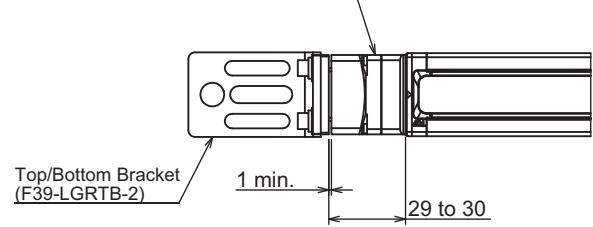

Lamp(F39-LP)/
Lamp and Bluetooth® Communication Unit (F39-BTLP)

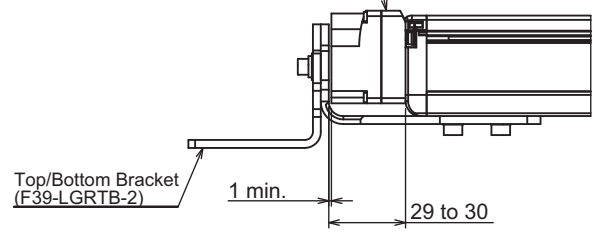

[Unit : mm]

[Top/Bottom Brackets (F39-LGRTB-3)]
Receiver

Lamp(F39-LP)/
Lamp and Bluetooth® Communication Unit (F39-BTLP)

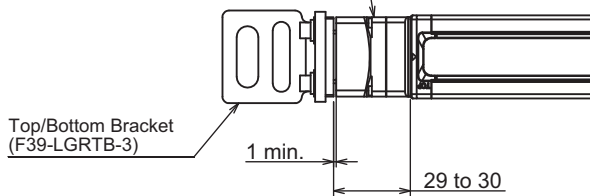

Lamp(F39-LP)/
Lamp and Bluetooth® Communication Unit (F39-BTLP)

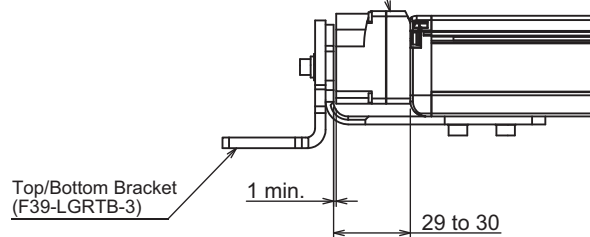

CHECK!

- Make sure to connect the F39-LP Lamp or F39-BTLP Lamp and Bluetooth® Communication Unit to the receiver.
- The F3SG-RR meets IP67* (IEC 60529) when it is correctly connected with the F39-LP Lamp or F39-BTLP Bluetooth® Communication Unit.

*When the accessory is used, protect it from cutting oil.

4-4. Mounting

4-4-1. Mounting Method

You can mount the F3SG-RR with Free-Location Brackets and Top/Bottom Brackets. Any of these mounting methods allows the user to use the same bracket for the backside mounting and side mounting.

4-4-2. Number of Brackets Required

The numbers of brackets required according to the protective heights of the sensor are as follows:

- Mounting with Free-Location Brackets Only

Protective height	Number of Free-Location Brackets *1
0240 to 1200	2 *2
1280 to 1920	3

- Mounting with Top/Bottom Brackets (F39-LGRTB-□) and Intermediate Bracket (F39-LGRA)

Protective height	Number of Top/Bottom Brackets *1	Number of Intermediate Brackets *1
0240 to 1040	2	0
1120 to 1920	2	1

*1. The number of brackets required to mount either one of emitter and receiver.

*2. Mounting an emitter or receiver with one bracket is possible for the model of protective height of 0240. In this case, locate this bracket at the center of the sensor length.



CHECK!

Make sure that the F3SG-RR is securely mounted and its cables and connectors are properly connected.

4-4-3. Mounting Procedure

■ Before mounting

When it is required to configure the following functions, do so before installing the F3SG-RR in your site, according to the respective procedures.

- Scan Code Selection: 2-4. Scan Code Selection
- External Test Input Selection: 2-7. External Test

4-4-3-1. Mounting with Free-Location Brackets (F39-LGRA)

1. Securely tighten the screws to fix the Free-Location Bracket to the mounting position of the wall surface. (Fig. 1)

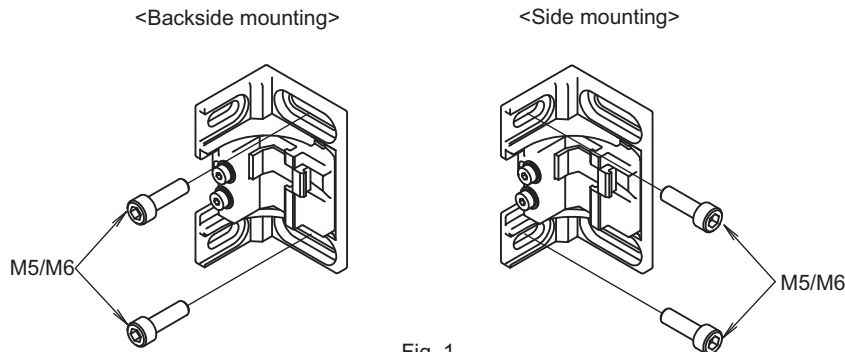

Fig. 1



CHECK!

Screws to mount the brackets to the wall are not included.

2. Fully loosen the Mounting Screws (hexagon socket head cap screw (M4×22)). Fit the backside of the F3SG-RR housing to the Brackets (1) and (2) so that the groove of the backside of the housing receives the hooks of the Brackets (1) and (2). (Fig. 2)

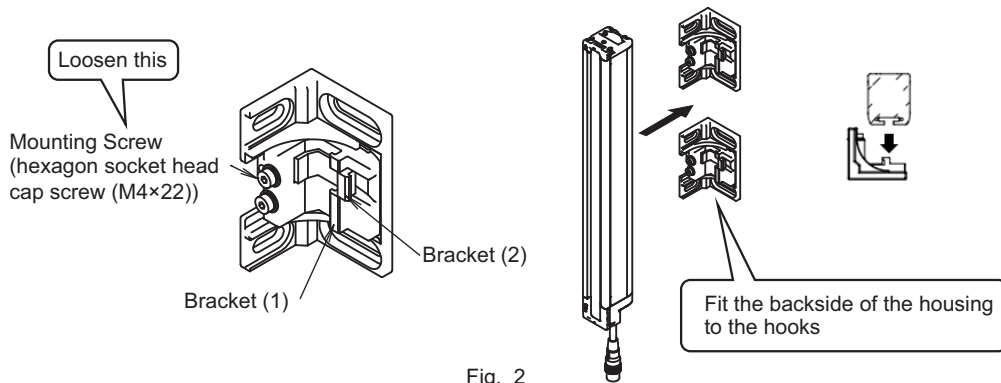

Fig. 2



CHECK!

The width across flat of the hexagon socket of the Mountng Screws is S=3.

- Securely tighten the Mounting Screws to fix the Free-Location Bracket to the F3SG-RR housing. The recommended torque to tighten the Mounting Screws is 3.0 N•m. Then loosen the Alignment Screws (hexagon socket head cap screws (M4×22)). (Fig. 3)

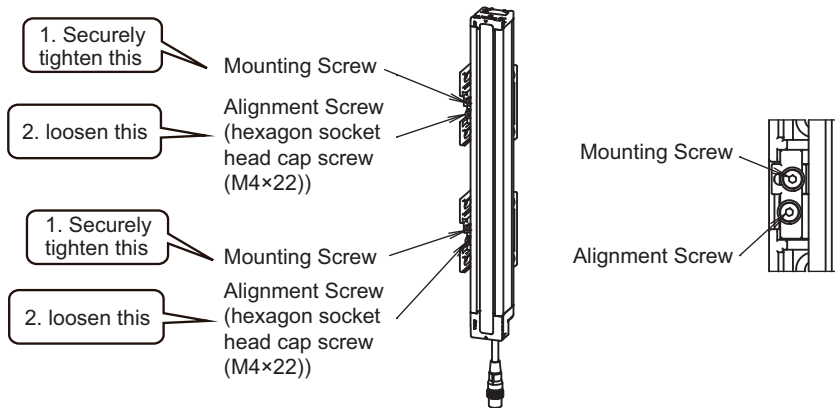

Fig. 3



CHECK!

- Tightening screws with a torque that considerably exceeds the recommended torque may cause failure.
- The width across flat of the hexagon socket of the Alignment Screws is S=3.

- Power the F3SG-RR on to perform beam alignment.

Move the emitter and receiver from side to side (Fig. 4) to align them to a center position where the Stable-state indicator (STB, green) of the receiver is illuminated while checking the state of the top and bottom beams with the Top-beam-state indicator (TOP, blue) and Bottom-beam-state indicator (BTM, blue) of the receiver. (Fig. 6)

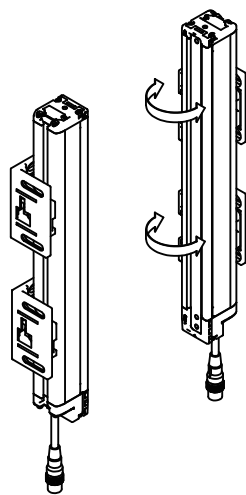

Fig. 4

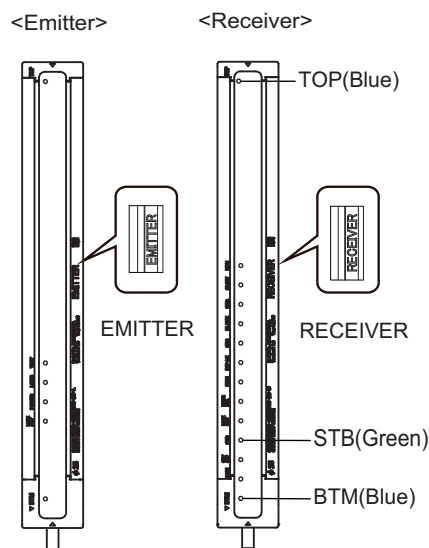

Fig. 5



CHECK!

- The angle adjustment range of the Free-Location Brackets is $\pm 15^\circ$.
- The Stable-state indicator (STB, green) will not be illuminated if the blanking function is used and there is a blocking object in the detection zone. Perform beam alignment again to illuminate the Stable-state indicator (STB, green) after setting the blanking function.
- It is recommended to use the Light Level Monitoring with the Configuration Tool for beam alignment. Refer to *Safety Light Curtain Configuration Tool for Model F3SG (SD Manager 2) User's Manual* for more information.

5. Securely tighten the Alignment Screws to fix the Free-Location Bracket to the F3SG-RR housing. The recommended torque to tighten the Alignment Screws is 3.0 N•m. (Fig. 6)

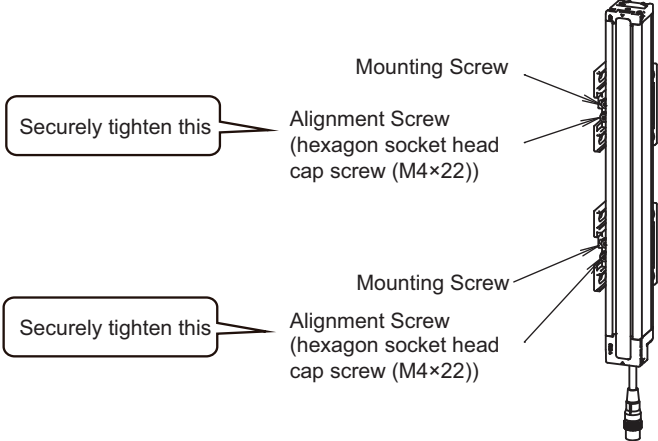

Fig. 6



Tightening screws with a torque that considerably exceeds the recommended torque may cause failure.

CHECK!

4-4-3-2. Mounting with Top/Bottom Bracket (F39-LGRTB-□) and Intermediate Bracket (F39-LGRA)

The mounting procedure below shows the procedure using the F39-LGRTB, but this procedure is also applicable to the F39-LGRTB-2 and F39-LGRTB-3.

1. Loosen the Alignment Screws (hexagon socket head cap screw (M4×7)) of the Top/Bottom Bracket (3) and change the angle of the Top/Bottom Bracket (3) according to its mounting direction. Then loosen the Mounting Screws (low head hexagon socket head cap screw (M4×7)) of Top/Bottom Bracket (2). (Fig. 1)

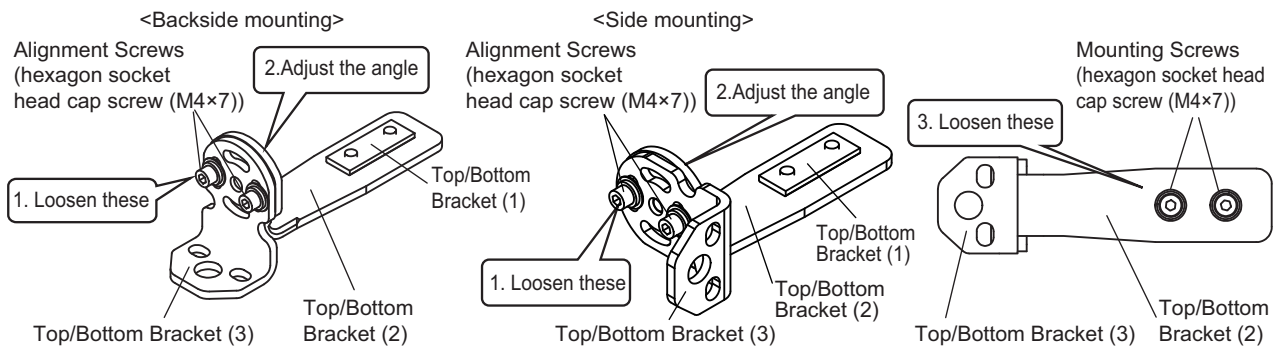

Fig. 1



The width across flat of the hexagon socket of the Alignment Screws and Mounting Screws is S=3.

2. Slide the Top/Bottom Bracket (1) in the grooves of the F3SG-RR housing. Adjust the Top/Bottom Bracket to the mounting position of the wall surface. Make sure to position the whole body of the Top/Bottom Bracket (1) within the golden area of the housing. Securely tighten the Mounting Screws to fix the Top/Bottom Bracket to the housing of the F3SG-RR. The recommended torque to tighten the Mounting Screws is 3.0 N•m. (Fig. 2)

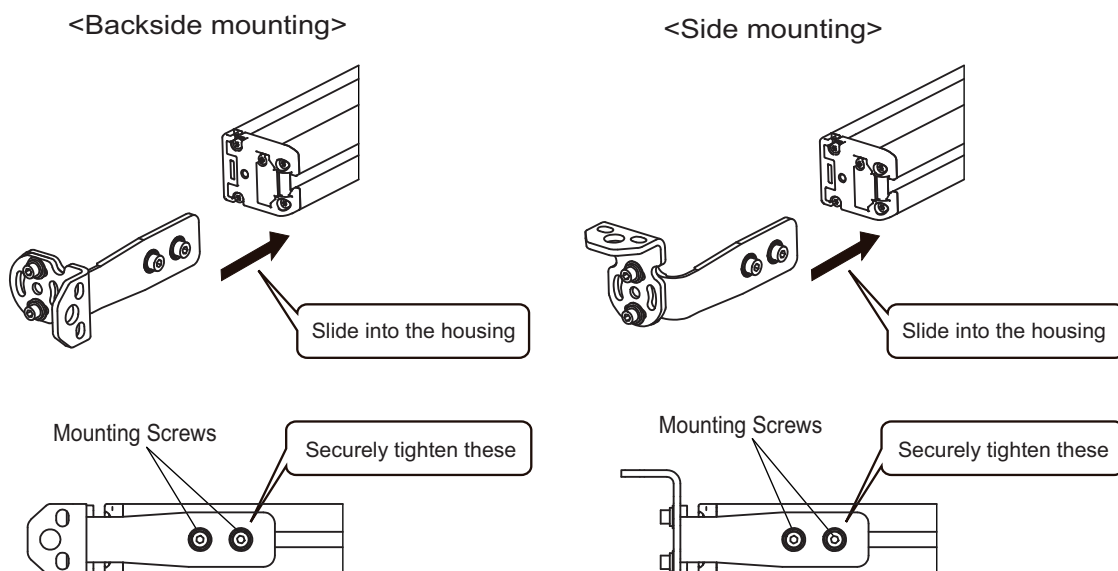

Fig. 2



Tightening screws with a torque that considerably exceeds the recommended torque may cause failure.

- Securely tighten screws to fix the Intermediate Bracket to the mounting position of the wall surface. (Fig. 3)

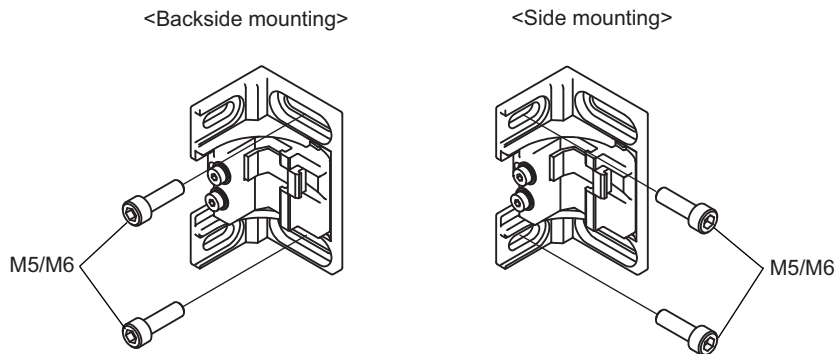

Fig. 3



CHECK!

- Screws to mount the brackets to the wall are not included.
- This step is not needed for the F3SG-RR of the protective height of 1040 mm or less.

- Fully loosen the Mounting Screw (hexagon socket head cap screw (M4×22)) of the Intermediate Bracket. (Fig. 4) Then slide the hooks of the Brackets (1) and (2) in the groove of the backside of the F3SG-RR housing. (Fig. 5)

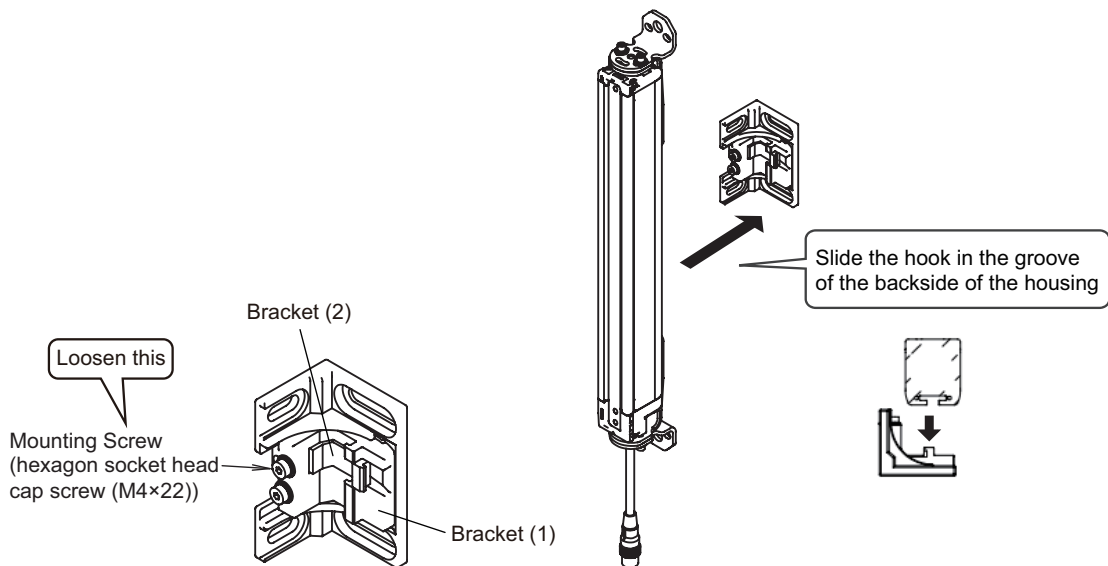

Fig. 4

Fig. 5



CHECK!

- This step is not needed for the F3SG-RR of the protective height of 1040 mm or less.

- Securely tighten the Mounting Screw to fix the Intermediate Bracket to the F3SG-RR housing. The recommended torque to tighten the Mounting Screw is 3.0 N·m. Then loosen the Alignment Screw (hexagon socket head cap screw (M4×22)) of the Intermediate Bracket. (Fig. 6)

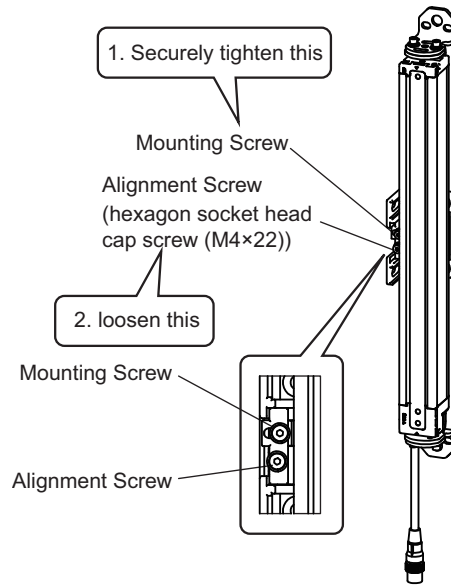

Fig. 6



Tightening screws with a torque that considerably exceeds the recommended torque may cause failure.

CHECK!

- Securely tighten screws to fix the Top/Bottom Bracket to the mounting position of the wall surface. (Fig. 7)

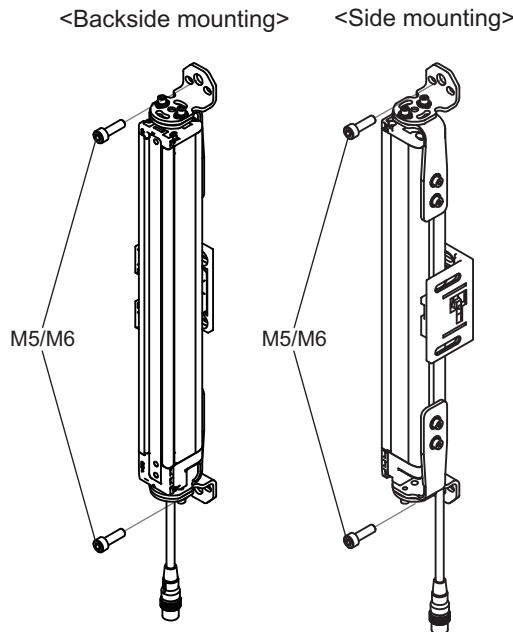

Fig. 7



- One screw at upper and lower positions, respectively, is sufficient to fix the F3SG-RR to the wall surface.
- Screws to mount the brackets to the wall are not included.

CHECK!

7. Power the F3SG-RR on to perform beam alignment.

Move the emitter and receiver from side to side (Fig. 8) to align them to a center position where the Stable-state indicator (STB, green) of the receiver is illuminated while checking the state of the top and bottom beams with the Top-beam-state indicator (TOP, blue) and Bottom-beam-state indicator (BTM, blue) of the receiver. (Fig. 9)

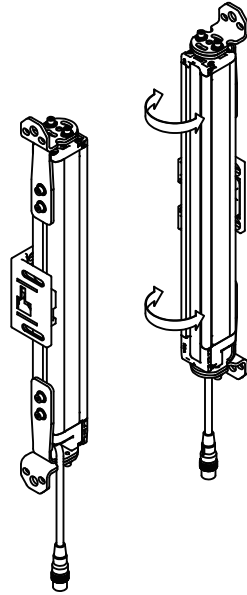

Fig. 8

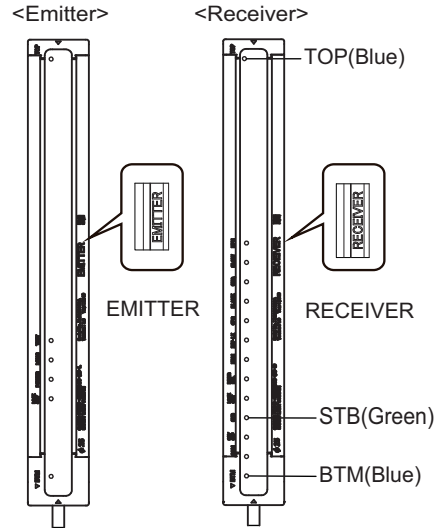

Fig. 9



- The angle adjustment range is $\pm 22.5^\circ$ when using the Top/Bottom Brackets only.
- The angle adjustment range is $\pm 15^\circ$ when using the Top/Bottom Brackets and Intermediate Bracket together.
- The Stable-state indicator (STB, green) will not be illuminated if the blanking function is used and there is a blocking object in the detection zone. Perform beam alignment again to illuminate the Stable-state indicator (STB, green) after setting the blanking function.
- It is recommended to use the Light Level Monitoring with the Configuration Tool for beam alignment. Refer to *Safety Light Curtain Configuration Tool for Model F3SG (SD Manager 2) User's Manual* for more information.

8. Securely tighten the Alignment Screws of the Top/Bottom Bracket and Intermediate Bracket to fix the bracket to the F3SG-RR housing. The recommended torque to tighten the Alignment Screws is 3.0 N•m. (Fig. 10)

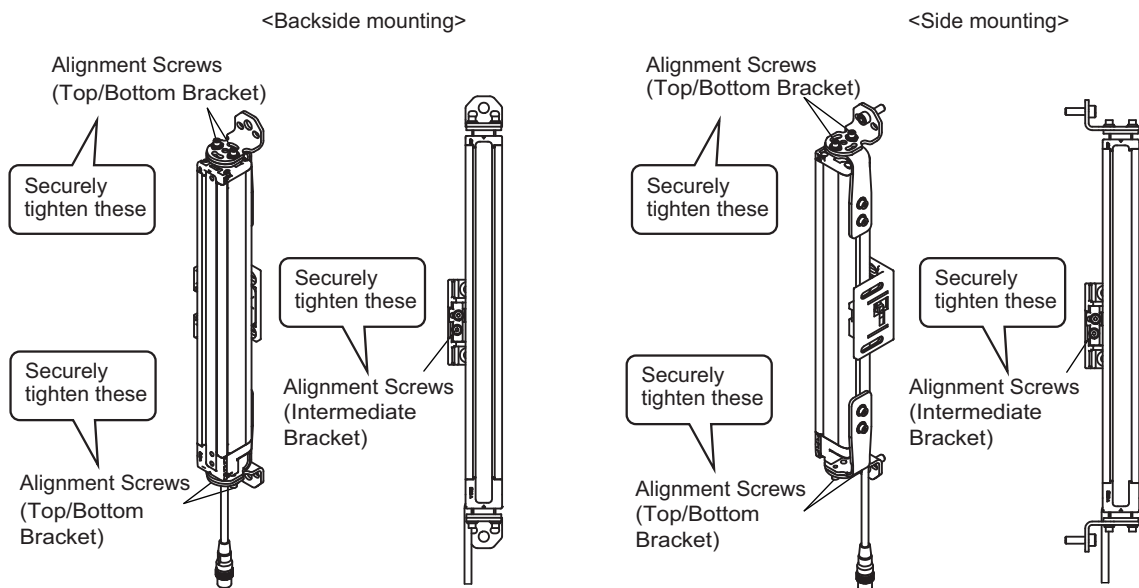

Fig. 10



Tightening screws with a torque that considerably exceeds the recommended torque may cause failure.

4-4-4. Beam Alignment Procedure



The Free-Location Bracket and Top/Bottom Bracket allow beam alignment after fixing the bracket to a wall surface.

1. Verify the following points:

- The optical surfaces of the emitter and receiver are clean.
- There is no interrupting object in the detection zone of the F3SG-RR.

2. Align the beams of the emitter and receiver:

Move the emitter and receiver from side to side to align each of these to the center position where the Stable-state indicator (STB, green) of the receiver is illuminated while checking the state of the top and bottom beams with the Top-beam-state indicator (TOP, blue) and Bottom-beam-state indicator (BTM, blue) of the receiver.



1-4. LED Indicators



Perform beam alignment to the primary sensor first, when using the F3SG-RR in a cascade connection.

3. Verify that all the three indicators of the receiver, Top-beam-state (TOP, blue), Bottom-beam-state (BTM, blue) and Stable-state (STB, green) indicators are illuminated.

4. Make sure to keep the beams aligned and tightly fasten all screws.

The table below shows the recommended tightening torques for the included screws.

Mounting bracket type	Nominal diameter x length of screw (mm)	Tightening torque (recommended)
Free-Location Bracket (Intermediate Bracket)	M4 x 22	3.0 N•m
Top/Bottom Bracket	M4 x 7	3.0 N•m



- If any of the Top-beam-state (TOP, blue), Bottom-beam-state (BTM, blue) and Stable-state (STB, green) indicators are not illuminated, check if the emitter and receiver are mounted parallel and at the same height.

- Tightening screws with a torque that considerably exceeds the recommended torque may cause failure.

- It is recommended to use the Light Level Monitoring with the Configuration Tool for beam alignment. Refer to *Safety Light Curtain Configuration Tool for Model F3SG (SD Manager 2) User's Manual* for more information.

4-5. Wiring

4-5-1. Wiring Precautions

⚠ WARNING

Double or reinforced insulation from hazardous voltage must be applied to all input and output lines. Failure to do so may result in electric shock.



When using PNP output, connect the load between the output and 0 V line. When using NPN output, connect the load between the output and +24 VDC line.



Connecting between the output and a different power supply line from the above line will result in dangerous condition because the operation mode of safety output is reversed to "Dark-ON".

When using the PNP output, do not ground +24 VDC line. When using the NPN output, do not ground 0 V line. Otherwise, a ground fault may turn the safety output ON, resulting in a failure of stopping the machine.



Configure the system by using the optimal number of safety outputs that satisfy the requirements of the necessary safety category.



Do not connect each line of F3SG-RR to a DC power supply higher than 24 VDC+20%. Also, do not connect it to an AC power supply. Failure to do so may result in electric shock.



Make sure to perform wiring while the power supply is OFF.

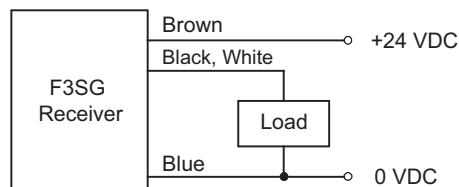
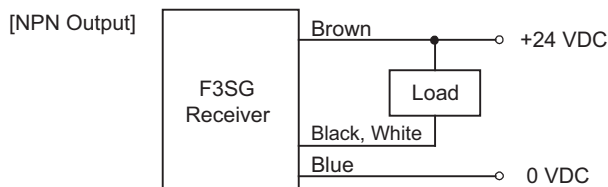
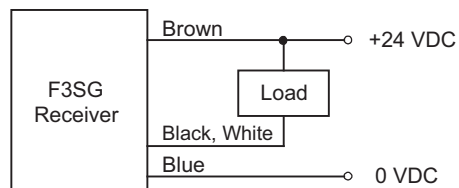
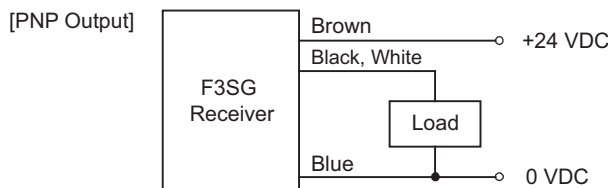

4-5-2. Power Supply Unit

WARNING

For the F3SG-RR to comply with IEC 61496-1 and UL 508, the DC power supply unit must satisfy all of the following conditions:



- Must be within the rated power voltage (24 V DC \pm 20%)
- Must have tolerance against the total rated current of devices if it is connected to multiple devices
- Must comply with EMC directives (industrial environment)
- Double or reinforced insulation must be applied between the primary and secondary circuits
- Automatic recovery of overcurrent protection characteristics
- Output holding time must be 20ms or longer
- Must satisfy output characteristic requirements for class 2 circuit or limited voltage current circuit defined by UL508 (Refer to Note below.)
- **Must comply with laws and regulations, regarding EMC and electrical equipment safety, of the country or region where the F3SG-RR is used (For example, in EU, the power supply must comply with the EMC Directive and the Low Voltage Directive.)**

Note:

To prevent a fire, the secondary circuit of the power supply must satisfy either of the following conditions in accordance with UL 508:

- As with secondary winding of isolation transformer, there must be a limited current voltage circuit to which isolated power supply provides power, and the "current is limited to 8 A max. (including short-circuit)" or "circuit protection such as a fuse is used to limit the current, which has a rating of 4.2A max." (24 VDC power supply).

Recommended power supply: OMRON S8VS (30 W or 60 W) or S8VK-G (15W, 30W or 60W)

These products are UL-Listed (UL508, class 2 power supply), CE marking compatible (EMC/Low Voltage Directive).

- Class 2 power supply unit complying with UL 1310, or a circuit using 2 transformers complying with UL 1585 as a power supply.



CHECK!

Sharing the power supply with other devices may cause the F3SG-R to be affected by noise or voltage drop. It is recommended that the F3SG-RR use a power supply dedicated for safety components, not shared with other devices.

4-5-3. Cable Connections

⚠ WARNING

Extension of the cable must be within a specified length. If it isn't, safety function may not work properly, resulting in danger.



Perform wiring according to the following procedure.

1. Connect an emitter cable (F39-JD□□□-L, gray, sold separately) to the emitter-side power cable (gray).
2. Connect a receiver cable (F39-JJD□□□-D, black, sold separately) to the receiver-side power cable (black).

4-5-3-1. Single-Ended Cable (Oil-Resistant Cable)

- Single-Ended Cable for Emitter (F39-JD□RA-L, sold separately)

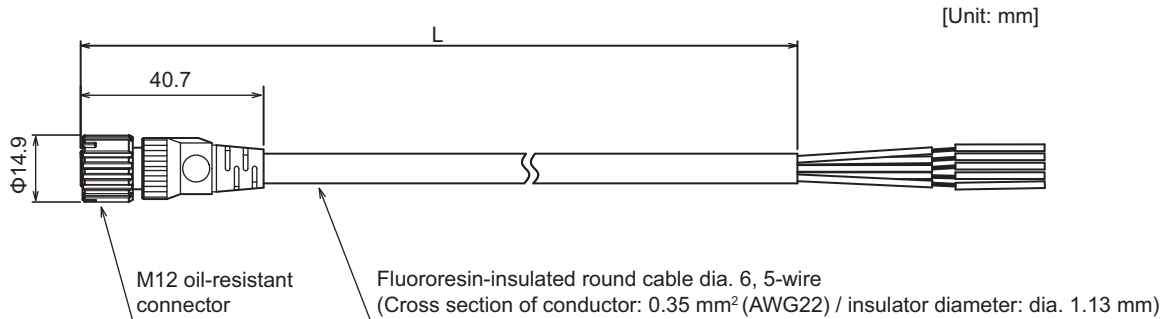

<Internal wiring diagram>

Connected to Power Cable or Double-Ended Cable

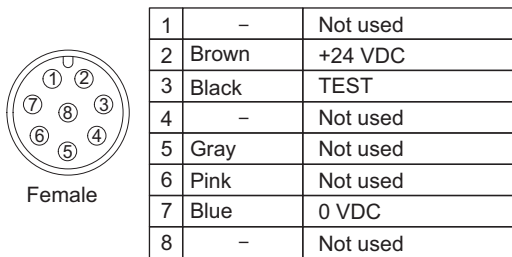

- Single-Ended Cable for Receiver (F39-JD□RA-D, sold separately)

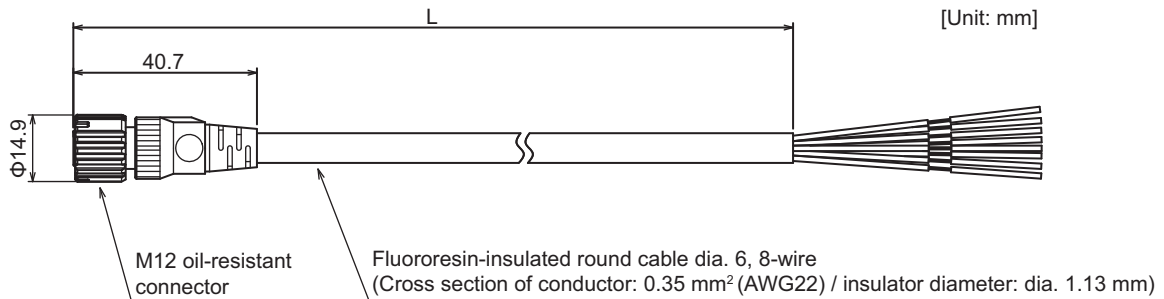

<Internal wiring diagram>

Connected to Power Cable or Double-Ended Cable



1	White	OSSD 2
2	Brown	+24 VDC
3	Black	OSSD 1
4	Yellow	AUX
5	Gray	MUTE A/PC COM (+)
6	Pink	MUTE B/PC COM (-)
7	Blue	0 VDC
8	Red	RESET/EDM

Emitter cable (Gray)	Receiver cable (Black)	L (m)
F39-JD3RA-L	F39-JD3RA-D	3
F39-JD7RA-L	F39-JD7RA-D	7

IP67 and IP67G (JIS C 0920 Annex 1)* rated when mated. *1

* F3SG-RR meets the degrees of protection when it is correctly connected with the power cable. The degree of protection is not satisfied with the part where cable wires are uncovered.

4-5-3-2. Single-Ended Cable

- Single-Ended Cable for Emitter (F39-JD□A-L, sold separately)

[Unit: mm]

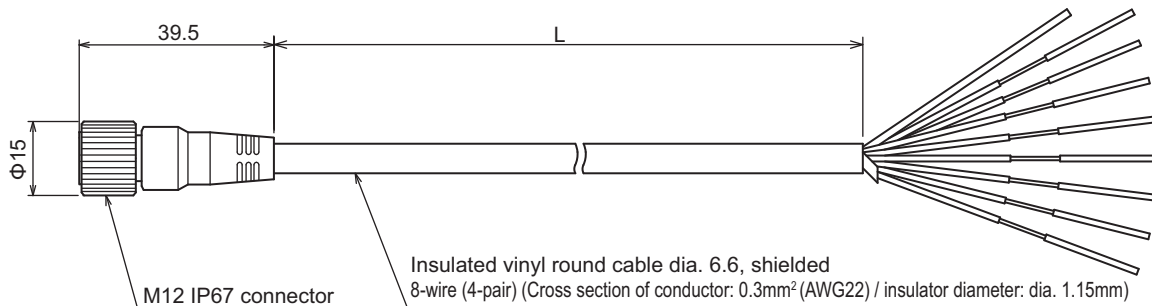

<Internal wiring diagram>

Connected to Power Cable or Double-Ended Cable



1	White	Not used
2	Brown	+24 VDC
3	Black	TEST
4	Yellow	Not used
5	Gray	Not used
6	Pink	Not used
7	Blue	0 VDC
8	Red	Not used
Shield		

- Single-Ended Cable for Receiver (F39-JD□A-D, sold separately)

[Unit: mm]

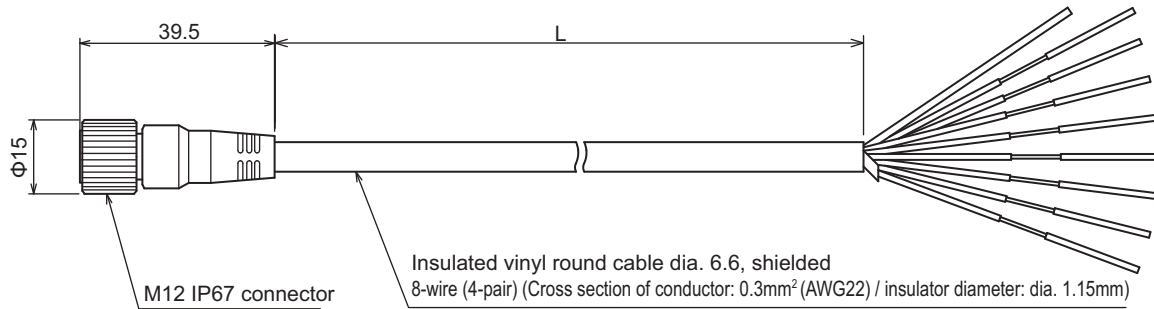

<Internal wiring diagram>

Connected to Power Cable or Double-Ended Cable



Female

1	White	OSSD 2
2	Brown	+24 VDC
3	Black	OSSD 1
4	Yellow	AUX
5	Gray	MUTE A/PC COM (+)
6	Pink	MUTE B/PC COM (-)
7	Blue	0 VDC
8	Red	RESET/EDM
Shield		

Emitter cable (Gray)	Receiver cable (Black)	L (m)
F39-JD3A-L	F39-JD3A-D	3
F39-JD7A-L	F39-JD7A-D	7
F39-JD10A-L	F39-JD10A-D	10
F39-JD15A-L	F39-JD15A-D	15
F39-JD20A-L	F39-JD20A-D	20

4-5-3-3. Double-Ended Cable

- Double-Ended Cable for Emitter: Cable for extension (F39-JD□B-L, sold separately)

[Unit: mm]

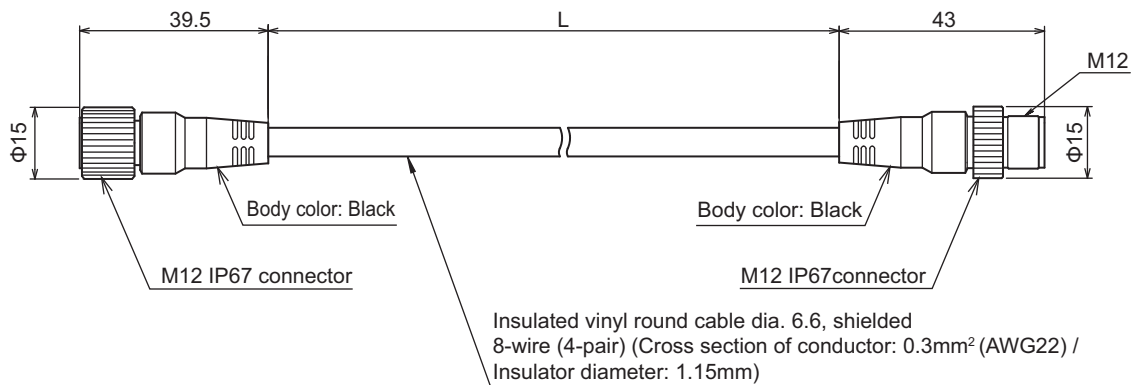

<Internal wiring diagram>

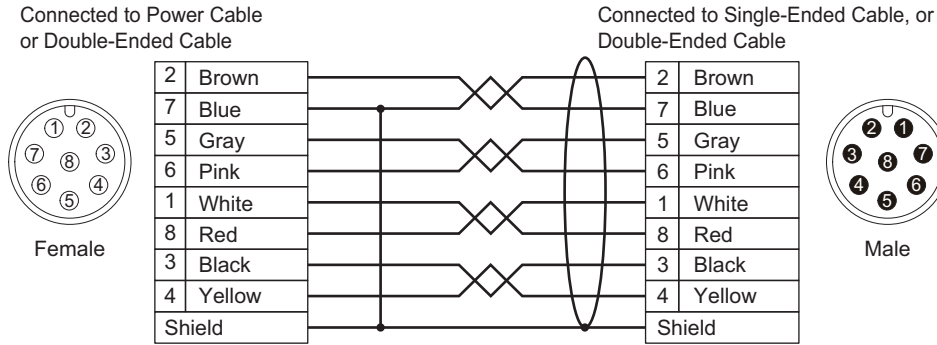

Twisted pair wires are brown and blue, gray and pink, white and red, and black and yellow.

▪ Double-Ended Cable for Receiver: Cable for extension (F39-JD□B-D, sold separately)

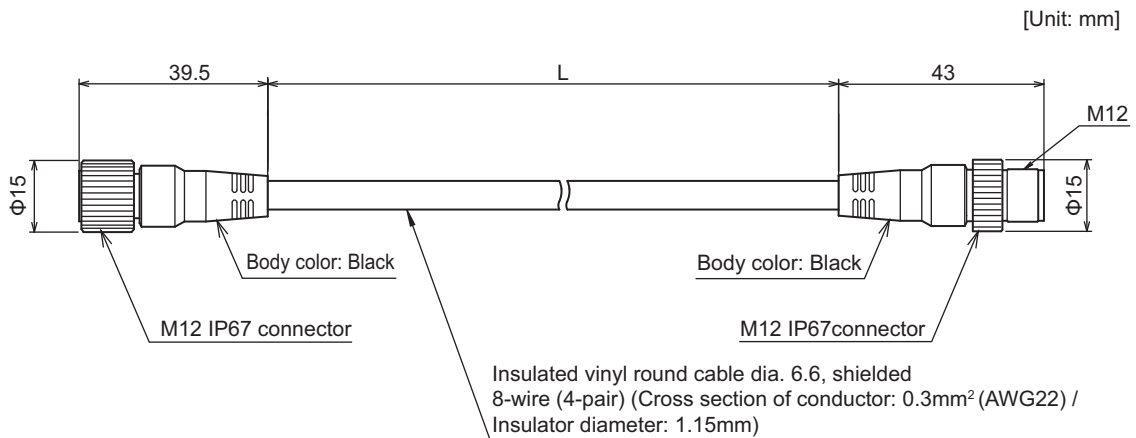

<Internal wiring diagram>

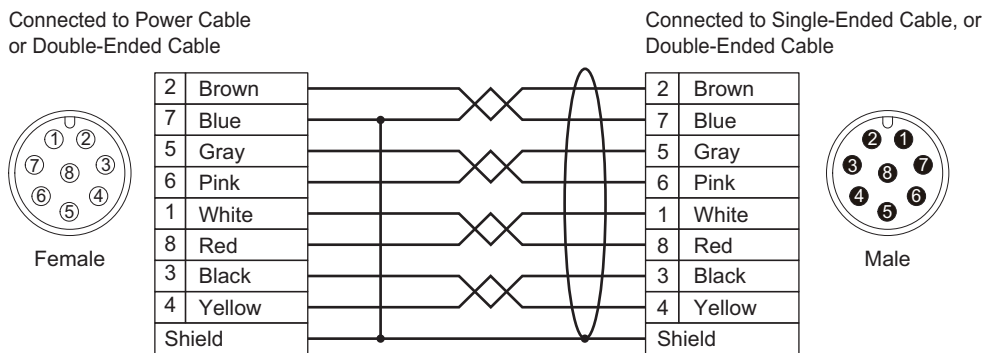

Twisted pair wires are brown and blue, gray and pink, white and red, and black and yellow.

Emitter cable (Gray)	Receiver cable (Black)	L (m)
F39-JDR5B-L	F39-JDR15B-D	0.5
F39-JD1B-L	F39-JD1B-D	1
F39-JD3B-L	F39-JD3B-D	3
F39-JD5B-L	F39-JD5B-D	5
F39-JD7B-L	F39-JD7B-D	7
F39-JD10B-L	F39-JD10B-D	10
F39-JD15B-L	F39-JD15B-D	15
F39-JD20B-L	F39-JD20B-D	20

If the length of the F39-JD□□A Single-Ended Cable is insufficient, use 1 or more F39-JD□B Double-Ended Cables to extend the length, as required. The total cable extension length of the power cable must be 100 m max.

<Connection example>

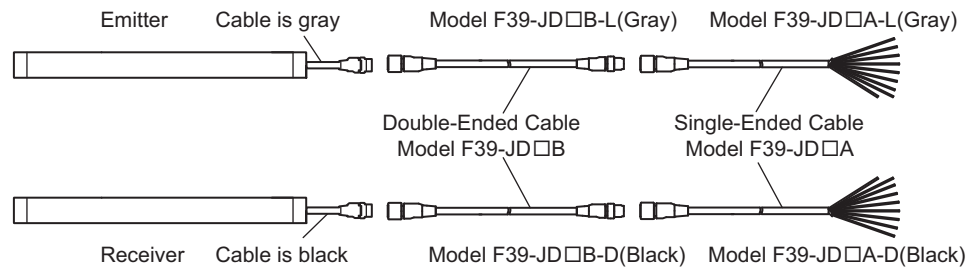

4-5-3-4. Cascading Cable

- Cascading Cable for Emitter (F39-JGR2WTS-L, sold separately)

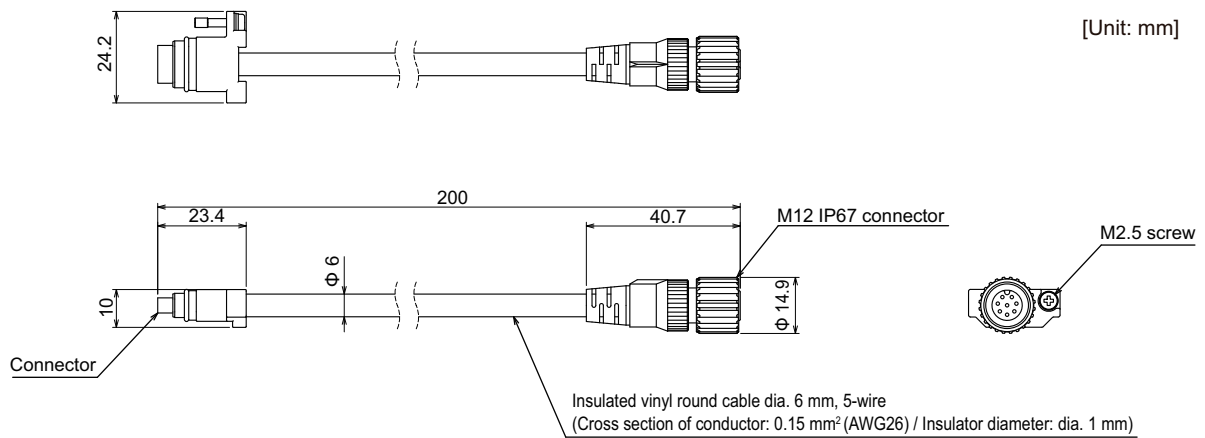

- Cascading Cable for Receiver (F39-JGR2WTS-D, sold separately)

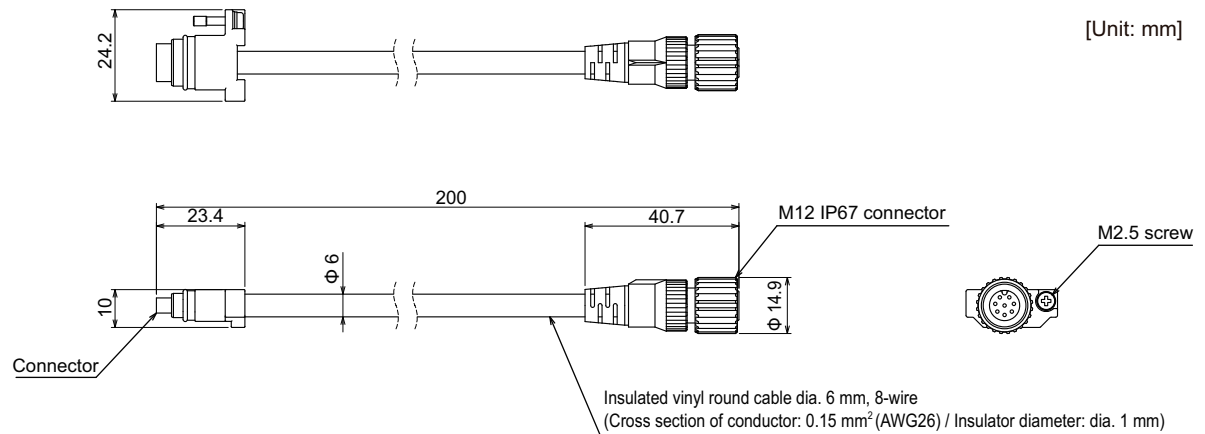

Set model name	Emitter cable (Gray)	Receiver cable (Black)	L (m)
F39-JGR2WTS	F39-JGR2WTS-L	F39-JGR2WTS-D	0.2

If the length of the Cascading Cable is insufficient, connect the F39-JD□B Double-Ended Cable between the power cable of the F3SG-RR and the F39-JGR2WTS Cascading Cable, as required. (Cable length between sensors: 10 m max. (not including cascading cable (F39-JGR2WTS) and power cable))

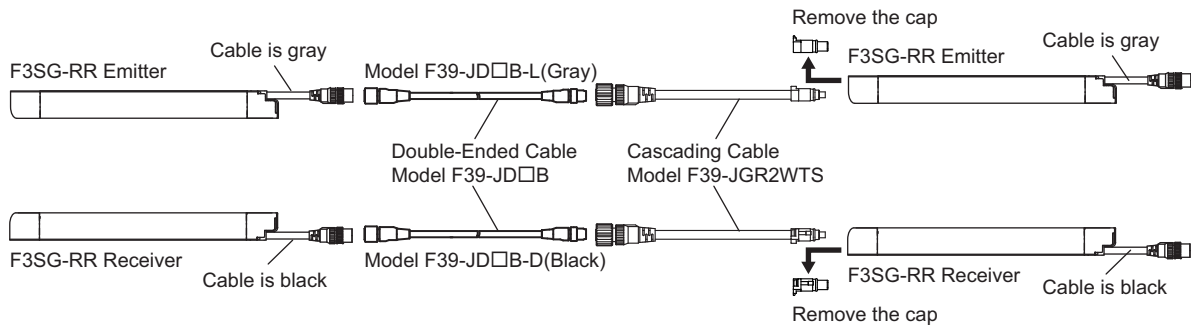

4-5-3-5. Reduced Wiring Connector System

▪ Reduced Wiring Connector System

The reduced wiring system can be achieved by using the Double-Ended Cable for Emitter (F39-JD□-B-L), the Single-Ended Cable for Receiver (F39-JD□A-D) and the Reduced Wiring Connector (F39-CN5).

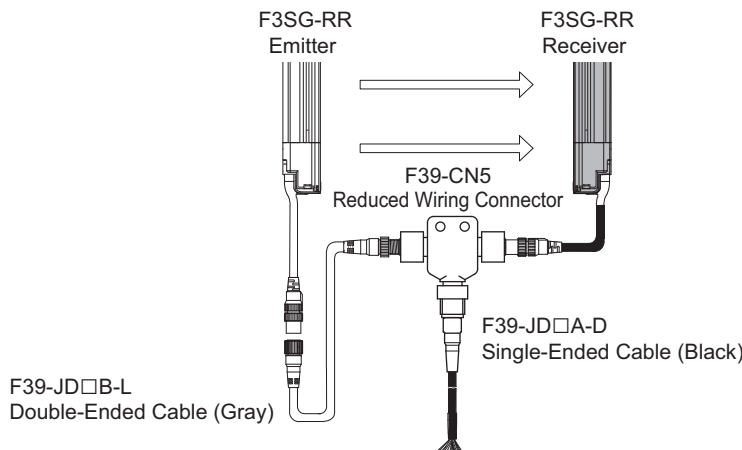



 When using the Reduced Wiring Connector (F39-CN5), the following functions are not available.
 - Manual Reset
 - External Device Monitoring
CHECK! - Auxiliary Output
 Make sure to keep the settings in the factory default.

▪ Cable for Reduced Wiring (F39-JD□BA, sold separately)

A set of two cables; a Double-Ended Cable for Emitter (F39-JD□B) and a Single-Ended Cable for Receiver (F39-JD□A-D). Used in combination with a reduced wiring connector (F39-CN5, sold separately).

See the following pages for details of the Double-Ended Cable for Emitter (F39-JD□B) and the Single-Ended Cable for Receiver (F39-JD□A-D).

-  4-5-3-2. Single-Ended Cable
-  4-5-3-3. Double-Ended Cable

▪ Reduced Wiring Connector (F39-CN5, sold separately)

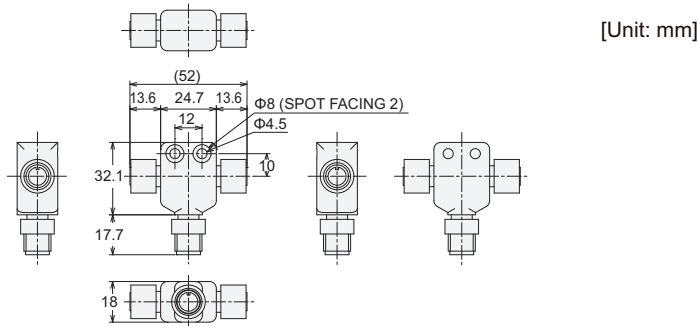

<Internal wiring diagram>

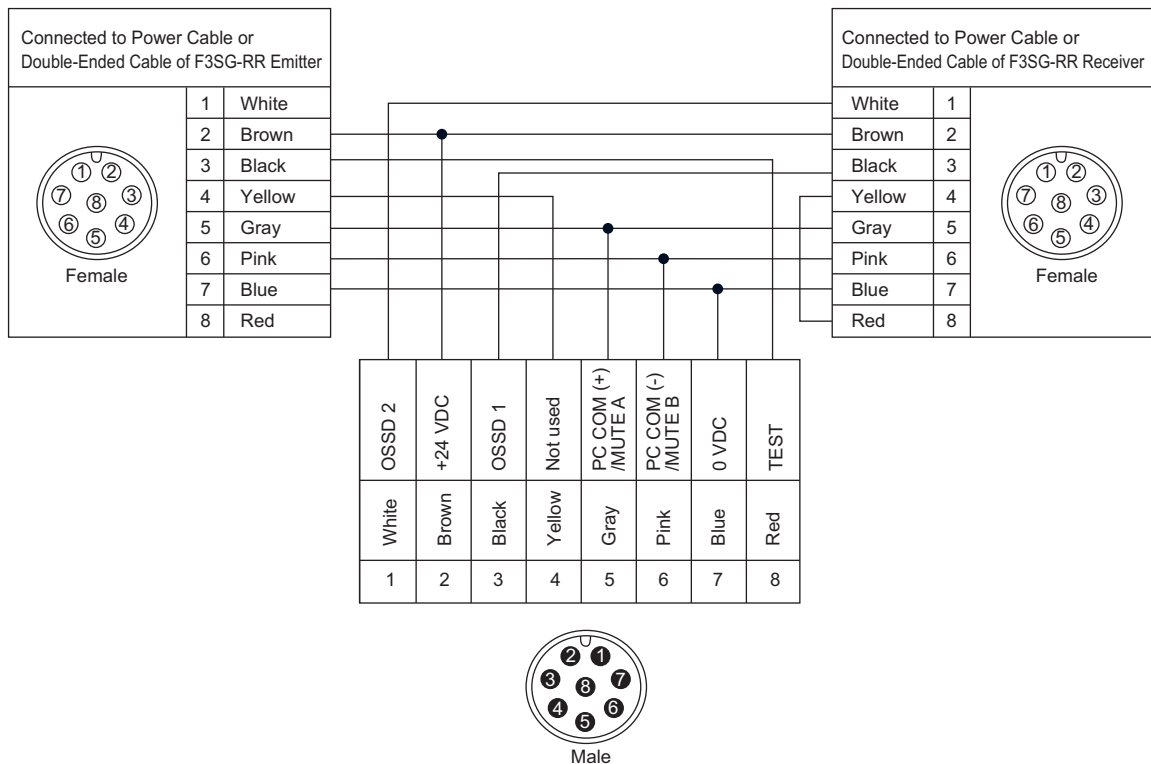

4-5-3-6. Extending Cable Length with Commercially Available Cable

When you need to use a cable that is not specified by OMRON, use a cable that satisfies the following specifications.

1. Emitter: 5-wire Receiver: 8-wire
2. 0.3 mm² or larger, conductor resistance 0.058 ohms/m max.
3. MUTE A/PC COM (+) and MUTE B/PC COM (-) lines, and 24 VDC and 0 VDC lines must be used as twisted-pair lines.



Do not use cables in the same conduit as high voltage or electric power lines.

CHECK!

4-5-4. Functional Earth Connection

The F3SG-RR operates properly without functional earth connection in a general industrial environment. If the F3SG-RR fails due to electrical noise, connecting the F3SG-RR to the functional earth may work to prevent the noise. It is recommended the functional earth terminal of the F3SG-RR be connected to functional earth cables. Connection with protective earth cables may cause the F3SG-RR to fail due to a noise level of the environment.

When you connect the F3SG-RR with the functional earth, connect an earth cable to the functional earth terminals, as shown below.

The size of the screws of the terminals is M3. Make sure to use crimp terminals that fits the size.

The earth cable must have a cross section of 1 mm² or more with conductor resistance of 0.058 ohms/m or less and a length of 20 m or less.

Bottom view of F3SG-RR

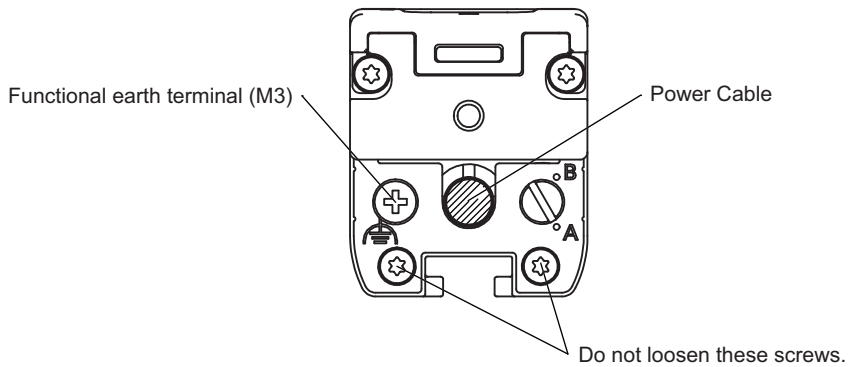

Chapter 5 Input/Output Circuit and Applications

5-1. Input/Output Circuit	157
5-1-1. Entire Circuit Diagram	157
5-1-2. Input Circuit Diagram by Function	159
5-2. Wiring Examples	160
5-2-1. Standalone F3SG-RR using PNP Outputs	160
5-2-1-1. Auto Reset Mode, EDM enabled and PNP Outputs	160
5-2-1-2. Manual Reset Mode, EDM disabled and PNP Outputs	161
5-2-1-3. Replacing the F3SJ-B Safety Light Curtain with F3SG-RR	162
5-2-1-4. F3SG-RR with Reduced Wiring Connector and PNP Outputs	163
5-2-1-5. Pre-Reset Mode using PNP Output	164
5-2-2. Muting using PNP Outputs	165
5-2-2-1. Standard Muting Mode/Exit-Only Muting Mode using PNP Outputs	165
5-2-2-2. Standard Muting Mode/Exit-Only Muting Mode with Reduced Wiring Connector and PNP outputs	166
5-2-2-3. Standard Muting Mode/Exit-Only Muting Mode with two Muting Sensors using PNP Outputs	167
5-2-2-4. Standard Muting Mode with four Muting Sensors using PNP Outputs	168
5-2-3. Standalone F3SG-RR using NPN Outputs	169
5-2-3-1. Auto Reset Mode, EDM enabled and NPN Outputs	169
5-2-3-2. Manual Reset Mode, EDM disabled and NPN Outputs	170
5-2-3-3. Replacing the F3SJ-B Safety Light Curtain with F3SG-RR	171
5-2-3-4. F3SG-RR with Reduced Wiring Connector and NPN Outputs	172
5-2-3-5. Pre-Reset Mode using NPN Output	173
5-2-4. Muting using NPN Outputs	174

5-2-4-1. Standard Muting Mode/Exit-Only Muting Mode using NPN Outputs	174
5-2-4-2. Standard Muting Mode/Exit-Only Muting Mode with two Muting Sensors using NPN Outputs	175
5-2-4-3. Standard Muting Mode with four Muting Sensors using NPN Outputs	176
5-3. Connectable Safety Control Units	177

5-1. Input/Output Circuit

5-1-1. Entire Circuit Diagram

The entire circuit diagram of the F3SG-RR is shown below.

The numbers in the circles indicate the connector's pin numbers.

■ PNP Output

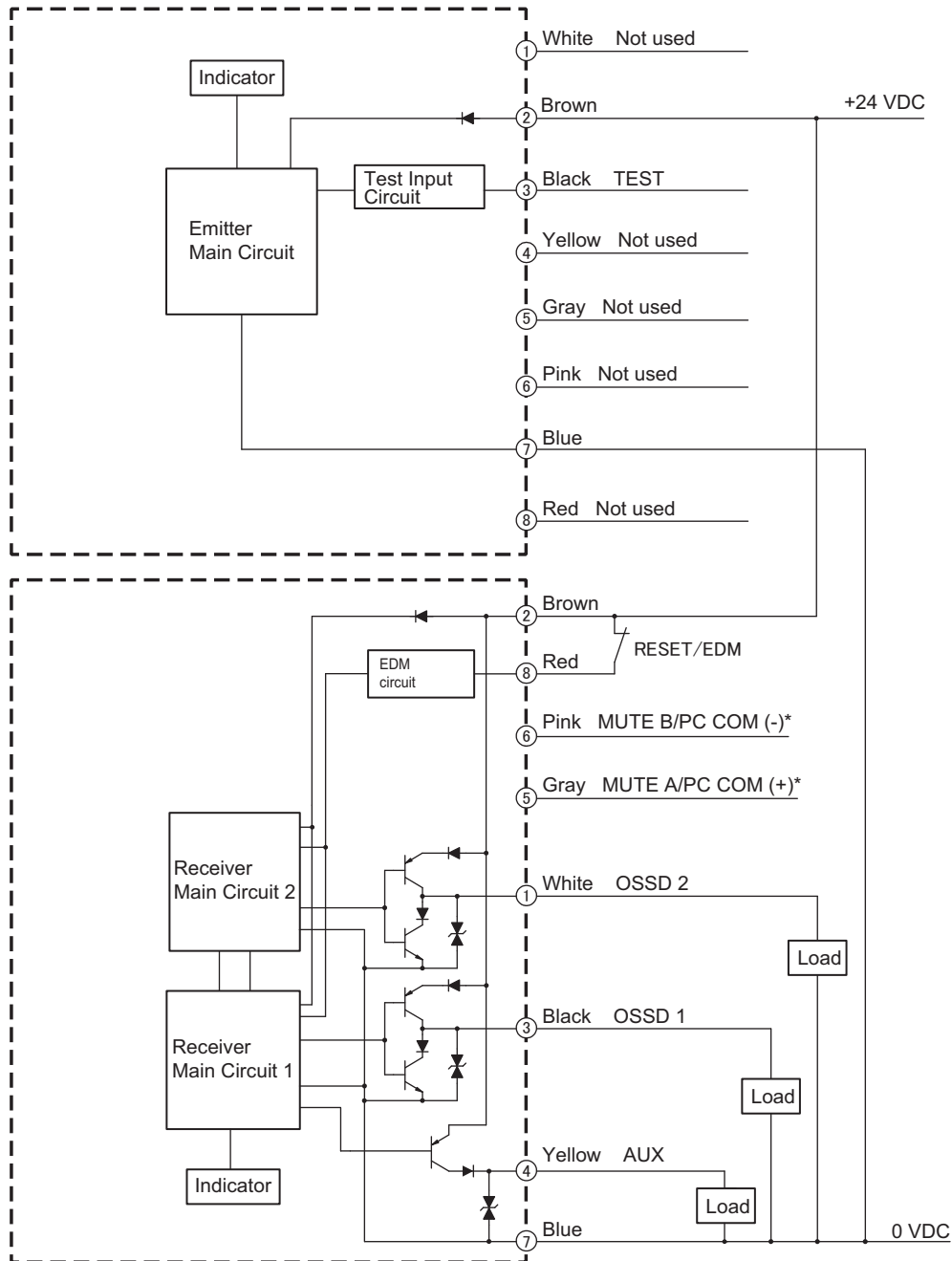

*This line is used for communication with a PC using the F39-GIF-1 Interface Unit.

■ NPN Output

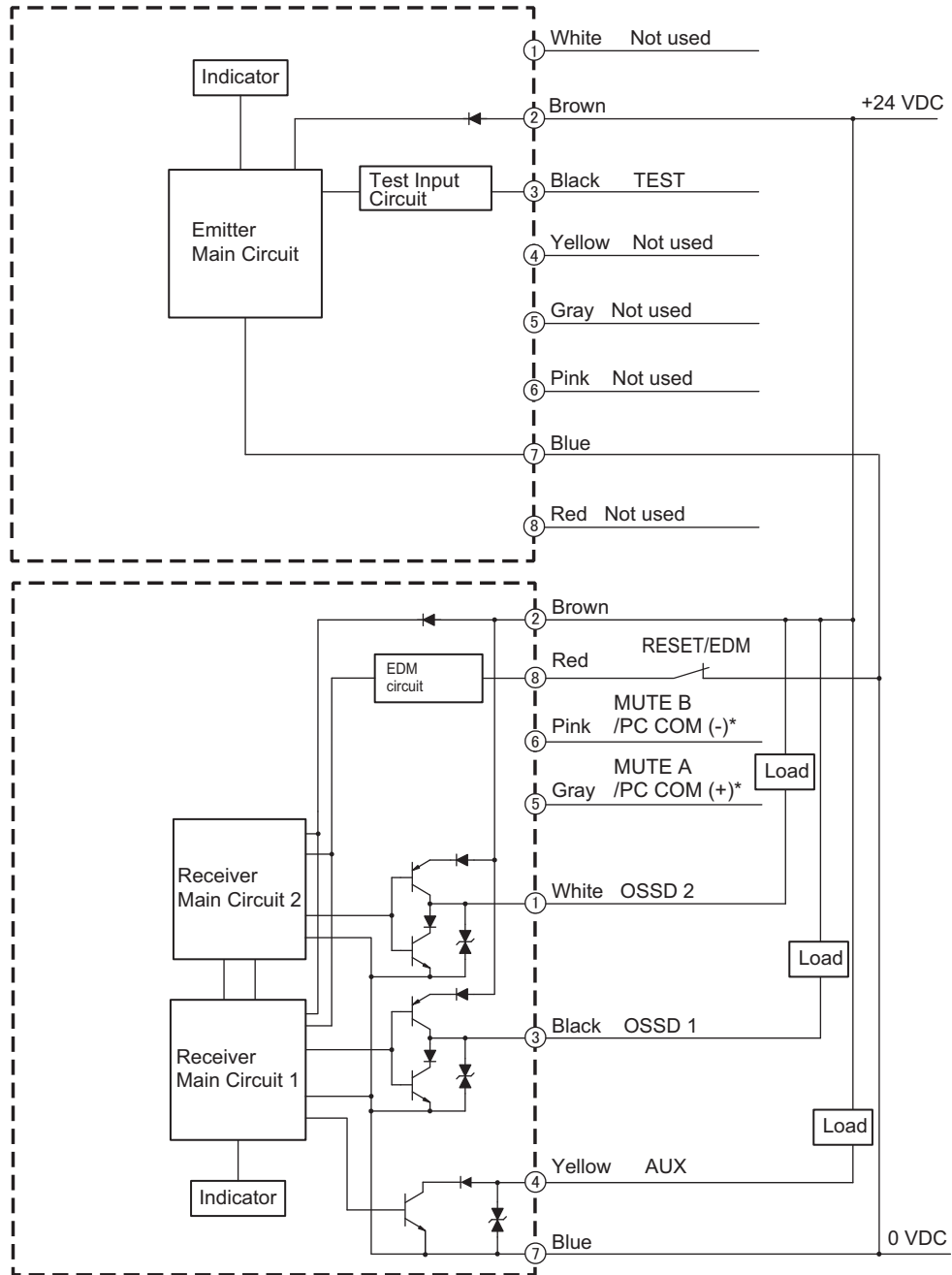

*This line is used for communication with a PC using the F39-GIF-1 Interface Unit.

5-1-2. Input Circuit Diagram by Function

The input circuit diagrams of by function are shown below.

■ TEST

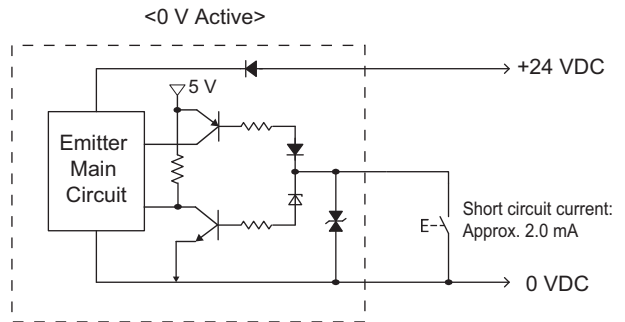
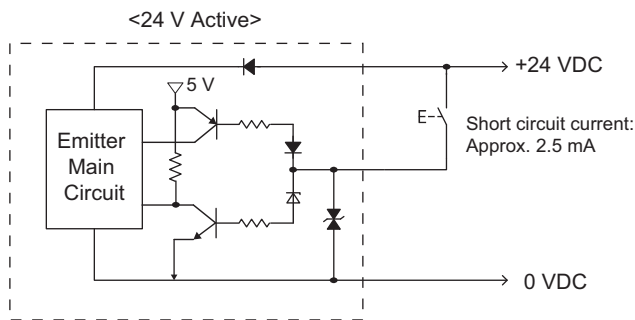

■ RESET/EDM, MUTE A/B

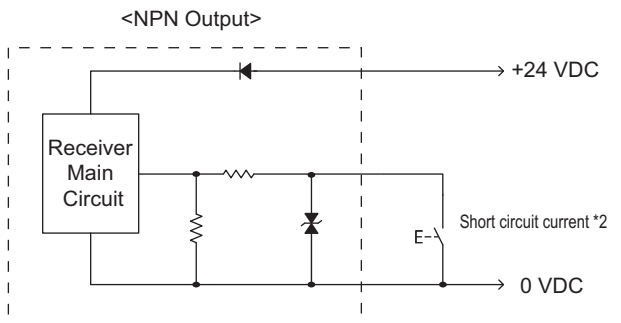
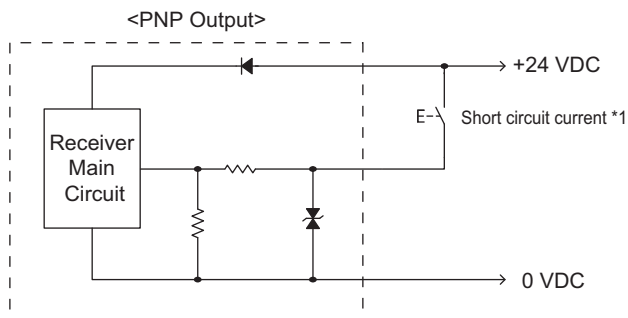

*1. Short circuit current: approx. 6.5 mA (RESET/EDM), approx. 3.0 mA (MUTE A/B)

*2. Short circuit current: approx. 8.0 mA (RESET/EDM), approx. 5.0 mA (MUTE A/B)

5-2. Wiring Examples

Examples of a motor control system using the F3SG-RR are shown below. This chapter shows examples equivalent to up to PLe, Category 4 (ISO13849-1).

5-2-1. Standalone F3SG-RR using PNP Outputs

5-2-1-1. Auto Reset Mode, EDM enabled and PNP Outputs

The following is the example of Muting not used, External Device Monitoring enabled, Auto Reset Mode, PNP outputs and External Test in 24 V Active (not used).

[Settings]

	Function
Receiver	EDM Enabled (factory default setting) *1
	Auto Reset (factory default setting) *1
	PNP (factory default setting) *1
Emitter	External Test: 24 V Active (End Cap: Black) (factory default setting)

[Wiring Example]

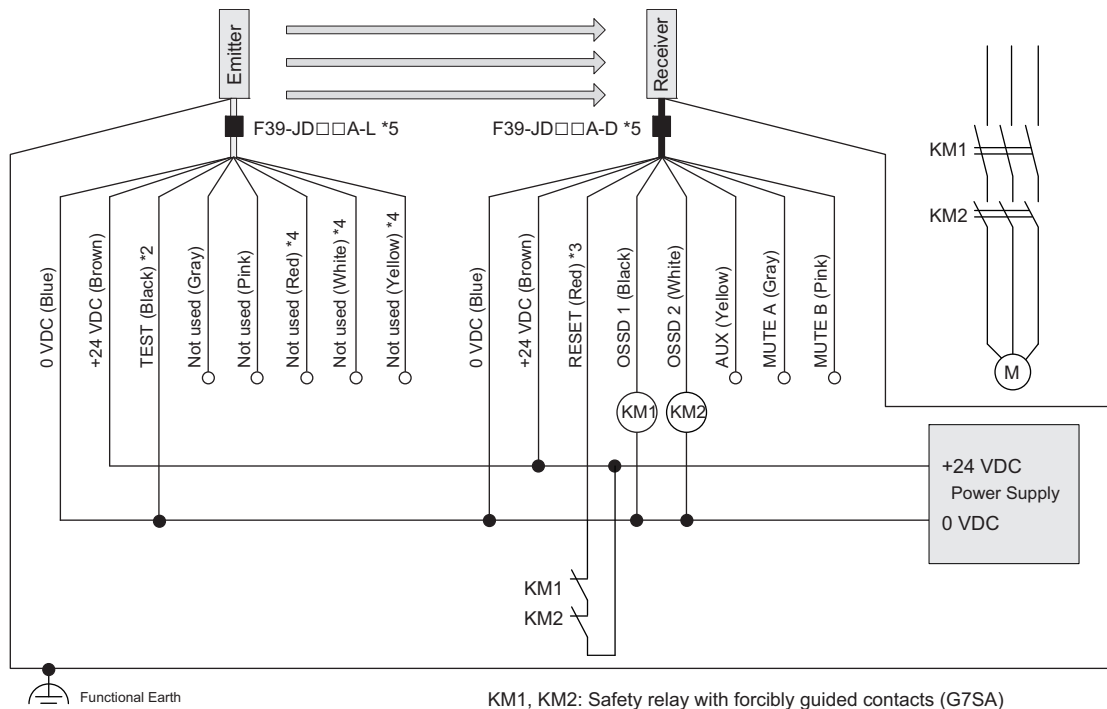

KM1, KM2: Safety relay with forcibly guided contacts (G7SA)
M: Motor

- *1. The functions are configurable with Configuration Tool. Refer to *Safety Light Curtain Configuration Tool for Model F3SG (SD Manager 2) User's Manual* for more information on setting the functions by the Configuration Tool.
- *2. Connect the line to 24 V via a test switch (NO contact) if External Test is used.
- *3. Also used as EDM line. Connect a lockout reset switch (NC contact) to this line in series with the KM1 and KM2 if Lockout Reset is used.
- *4. The F39-JD□□RA-L Single-Ended Cable for Emitter (Oil-Resistant Cable) does not have the red, white and yellow wires.
- *5. For the F39-JD□□A-□ Single-Ended Cable, connect the shield line to 0 V.



CHECK!

Functional earth connection is unnecessary when you use the F3SG-RR in a general industrial environment where noise control or stable power supply is considered. However, when you use the F3SG-RR in an environment where there may be excessive noise from surroundings or stable power supply may be interfered, it is recommended the F3SG-RR be connected to functional earth.

The wiring examples in later pages do not indicate functional earth. To use functional earth, wire an earth cable according to the example above. Refer to 4-5-4. *Functional Earth Connection* for more information.

5-2-1-2. Manual Reset Mode, EDM disabled and PNP Outputs

The following is the example of Muting not used, External Device Monitoring disabled, Manual Reset Mode, PNP outputs and External Test in 24 V Active (used).

[Settings]

	Function
Receiver	EDM Disabled *1
	Manual Reset *1
	PNP (factory default setting) *1
Emitter	External Test: 24 V Active (End Cap: Black) (factory default setting)

[Wiring Example]

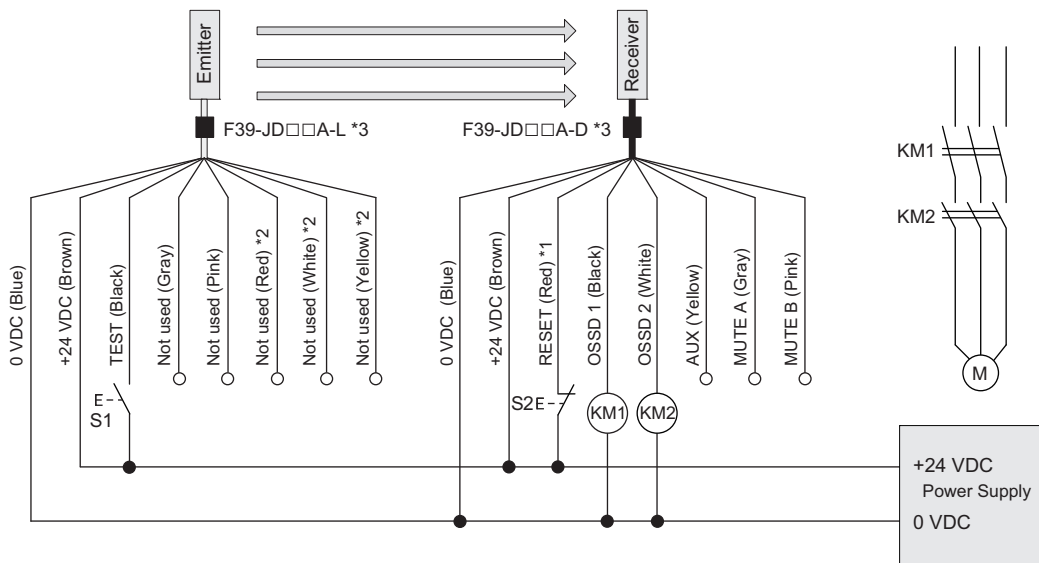

S1: Test Switch (Connect the line to 0 V if this switch is not required)
 S2: Lockout/Interlock Reset Switch
 KM1, KM2: Safety relay with forcibly guided contacts (G7SA)
 M: Motor

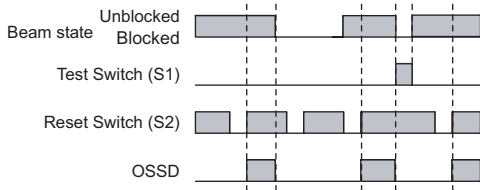

*1. The functions are configurable with Configuration Tool. Refer to *Safety Light Curtain Configuration Tool for Model F3SG (SD Manager 2) User's Manual* for more information on setting the functions by the Configuration Tool.

*2. The F39-JD□□A-L Single-Ended Cable for Emitter (Oil-Resistant Cable) does not have the red, white and yellow wires.

*3. For the F39-JD□□A-□ Single-Ended Cable, connect the shield line to 0 V.



The wiring example does not indicate functional earth. To use functional earth, wire an earth cable according to the example in 5-2-1-1. *Auto Reset Mode, EDM enabled and PNP Outputs*. Also refer to 4-5-4. *Functional Earth Connection* for more information.

5-2-1-3. Replacing the F3SJ-B Safety Light Curtain with F3SG-RR

The following is the example of External Device Monitoring enabled, Manual Reset Mode, PNP outputs and External Test in 24 V Active (used).

When replacing the F3SJ-B with F3SG-RR, change the wiring as shown below if using the Interlock/Lockout Reset function with the RESET line (yellow) of the F3SJ-B emitter.

[F3SJ-B Wiring Example]

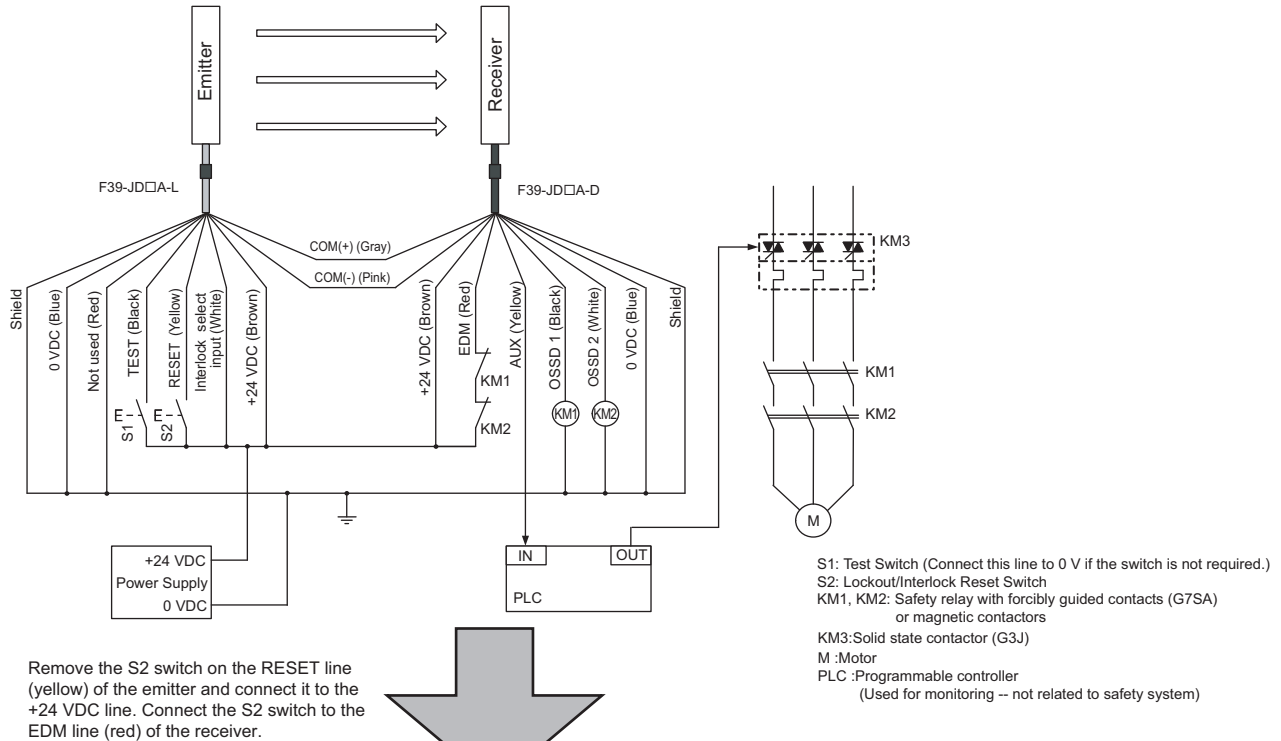

[Wiring Example to Replace with F3SG-RR]

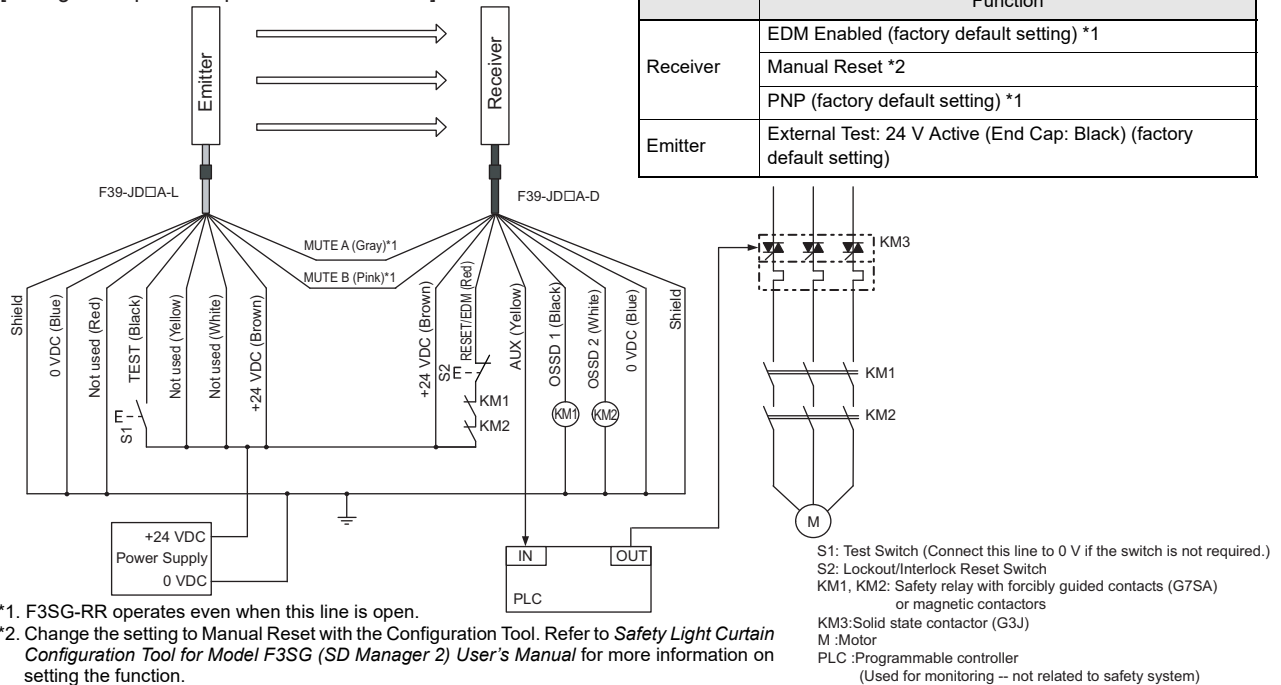

*1. F3SG-RR operates even when this line is open.

*2. Change the setting to Manual Reset with the Configuration Tool. Refer to *Safety Light Curtain Configuration Tool for Model F3SG (SD Manager 2) User's Manual* for more information on setting the function.

Connect the RESET line (yellow) used for the F3SJ-B emitter to +24 VDC line directly. This connection is not needed when using the Auto Rest Mode.

CHECK!

The wiring example does not indicate functional earth. To use functional earth, wire an earth cable according to the example in 5-2-1-1. *Auto Reset Mode, EDM enabled and PNP Outputs*. Also refer to 4-5-4. *Functional Earth Connection* for more information.

CHECK!

5-2-1-4. F3SG-RR with Reduced Wiring Connector and PNP Outputs

The following is the example of Muting not used, Auto Reset Mode, PNP outputs and External Test in 24 V Active (not used).

[Settings]

	Function
Receiver	Auto Reset (factory default setting) *1
	PNP (factory default setting) *1
Emitter	External Test: 24 V Active (End Cap: Black) (factory default setting)

The reduced wiring system can be achieved by using the Reduced Wiring Cables (F39-JD□BA) and the Reduced Wiring Connector (F39-CN5).

[Wiring Example]

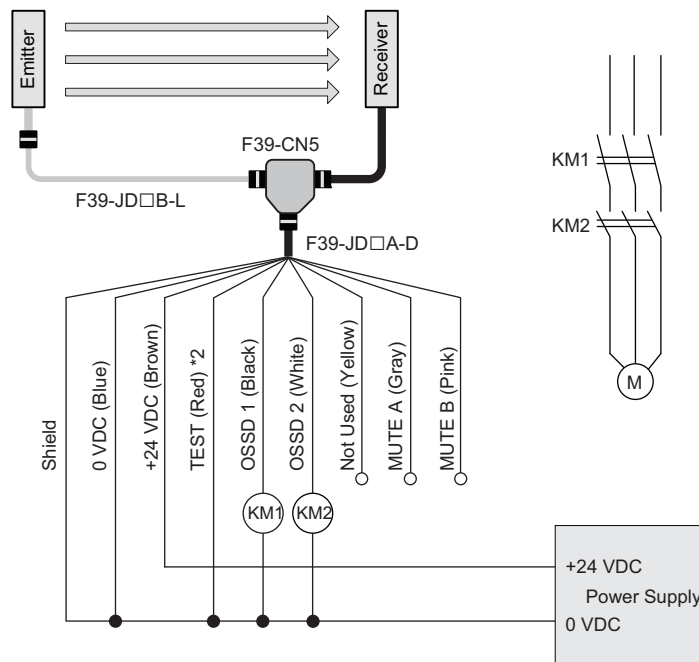

KM1, KM2: Safety relay with forcibly guided contacts (G7SA)
M: Motor

*1. The functions are configurable with Configuration Tool. Refer to *Safety Light Curtain Configuration Tool for Model F3SG (SD Manager 2) User's Manual* for more information on setting the functions by the Configuration Tool.

*2. Connect the line to 24 V via a test switch (NO contact) if External Test is used.

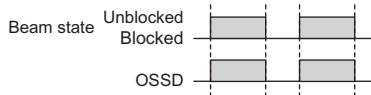

When using the Reduced Wiring Connector (F39-CN5), the following functions are not available.

- Manual Reset
- External Device Monitoring
- CHECK! - Auxiliary Output
- Override

Make sure to keep the settings in the factory default.



The wiring example does not indicate functional earth. To use functional earth, wire an earth cable according to the example in 5-2-1-1. *Auto Reset Mode, EDM enabled and PNP Outputs*. Also refer to 4-5-4. *Functional Earth Connection* for more information.

CHECK!

5-2-1-5. Pre-Reset Mode using PNP Output

The following is the example of External Device Monitoring disabled, Pre-Reset Mode, PNP outputs and External Test in 24 V Active (used).

[Settings]

	Function
Receiver	EDM Disabled *4
	Pre-Reset *4
	PNP Output (factory default setting) *4
Emitter	External Test: 24 V Active (End Cap: Black) (factory default setting)

[Wiring Example]

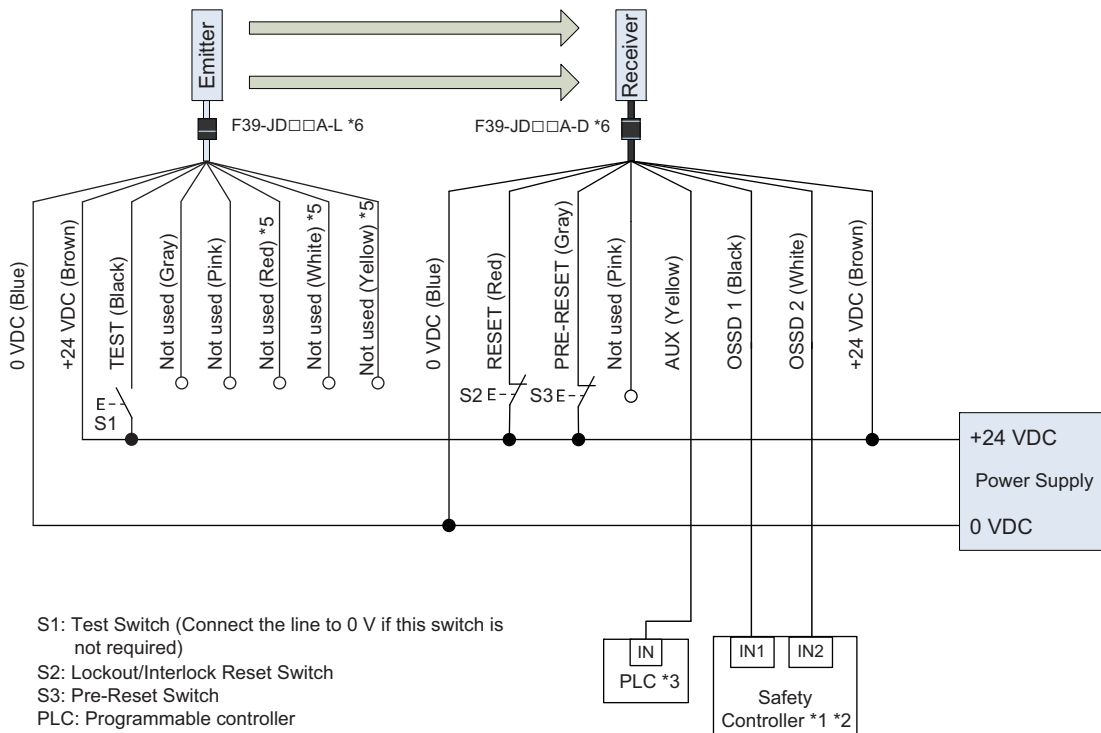

S1: Test Switch (Connect the line to 0 V if this switch is not required)

S2: Lockout/Interlock Reset Switch

S3: Pre-Reset Switch

PLC: Programmable controller

(Used for monitoring only. NOT related to safety system.)

*1. Refer to 5-3. *Connectable Safety Control Units* for more information.

*2. The safety controller and the F3SG-RR must share the power supply or be connected to the common terminal of the power supply.

*3. When connecting to the PLC, the output mode must be changed with the Configuration Tool according to your application.

*4. The functions are configurable with Configuration Tool. Refer to *Safety Light Curtain Configuration Tool for Model F3SG (SD Manager 2) User's Manual* for more information on setting the functions by the Configuration Tool.

*5. The F39-JD□□A-L Single-Ended Cable for Emitter (Oil-Resistant Cable) does not have the red, white and yellow wires.

*6. For the F39-JD□□A-□ Single-Ended Cable, connect the shield line to 0 V.

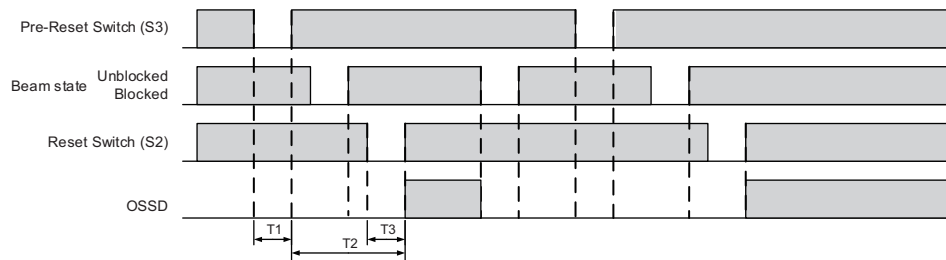

T1: Push time: must be $T1 \geq 300\text{ms}$

T2: Pre-reset limit time between Pre-reset and Reset: must be $T2 \leq 60\text{s}$

T3: Push time: must be $T3 \geq 300\text{ms}$



The wiring example does not indicate functional earth. To use functional earth, wire an earth cable according to the example in 5-2-1-1. *Auto Reset Mode, EDM enabled and PNP Outputs*. Also refer to 4-5-4. *Functional Earth Connection* for more information.

CHECK!

5-2-2. Muting using PNP Outputs

5-2-2-1. Standard Muting Mode/Exit-Only Muting Mode using PNP Outputs

The following is the example of External Device Monitoring enabled, Auto Reset Mode, PNP outputs and External Test in 24 V Active (used).

[Settings]

	Function
Receiver	EDM Enabled (factory default setting) *3
	Auto Reset (factory default setting) *3
	PNP Output (factory default setting) *3
Emitter	External Test: 24 V Active (End Cap: Black) (factory default setting)

[Wiring Example]

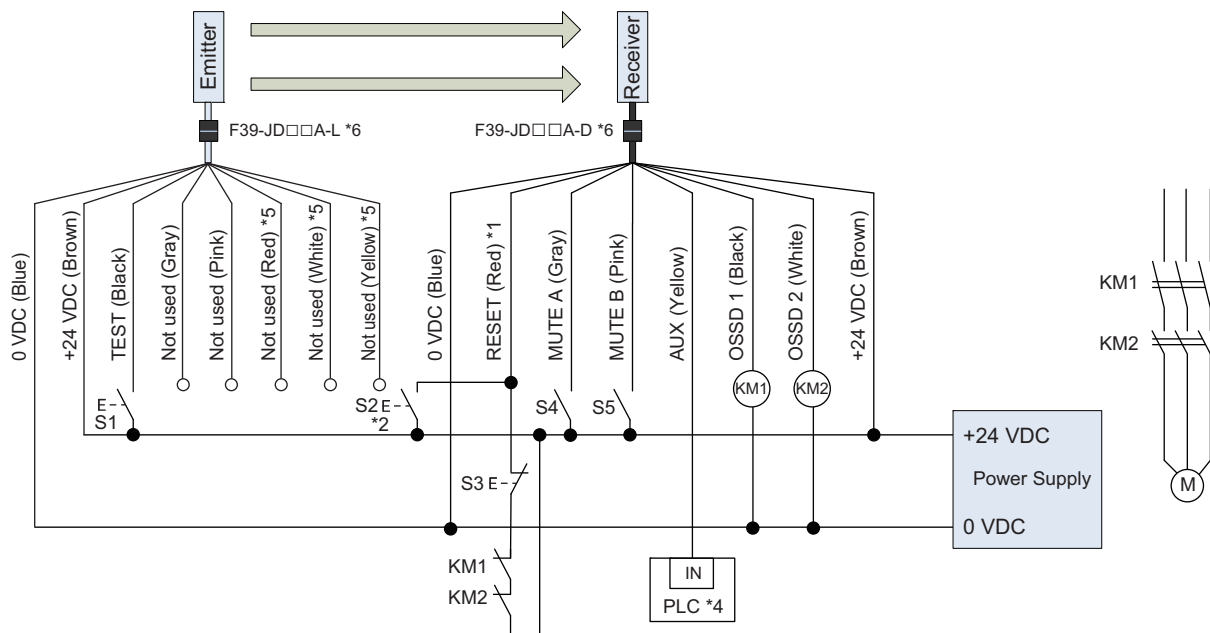

- S1: Test Switch (Connect the line to 0 V if this switch is not required)
- S2: Override Cancel Switch
- S3: Lockout Reset Switch or Override Switch
- S4, S5: Muting sensor
- KM1, KM2: Safety relay with forcibly guided contacts (G7SA) or magnetic contactor
- M: Motor

- *1. Also used as Override input or EDM line.
- *2. Make sure to connect an override cancel switch to the RESET line when using the override function. Otherwise the override state may not be released by the override cancel switch, resulting in serious injury.
- *3. The functions are configurable with Configuration Tool. Refer to *Safety Light Curtain Configuration Tool for Model F3SG (SD Manager 2) User's Manual* for more information on setting the functions by the Configuration Tool.
- *4. When connecting to the PLC, the output mode must be changed with the Configuration Tool according to your application.
- *5. The F39-JD□□RA-L Single-Ended Cable for Emitter (Oil-Resistant Cable) does not have the red, white and yellow wires.
- *6. For the F39-JD□□A-□ Single-Ended Cable, connect the shield line to 0 V.

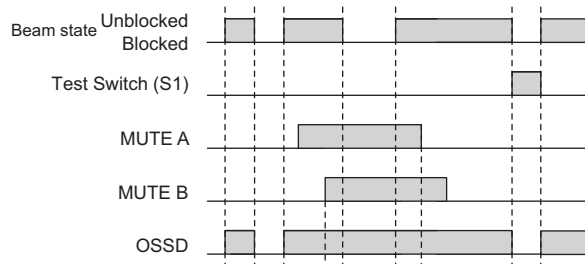

 The wiring example does not indicate functional earth. To use functional earth, wire an earth cable according to the example in 5-2-1-1. *Auto Reset Mode, EDM enabled and PNP Outputs*. Also refer to 4-5-4. *Functional Earth Connection* for more information.

CHECK!

5-2-2-2. Standard Muting Mode/Exit-Only Muting Mode with Reduced Wiring Connector and PNP outputs

The following is the example of Auto Reset Mode, PNP outputs and External Test in 24 V Active (not used).

[Settings]

	Function
Receiver	Auto Reset (factory default setting) *3
	PNP Output (factory default setting) *3
Emitter	External Test: 24 V Active (End Cap: Black) (factory default setting)

[Wiring Example]

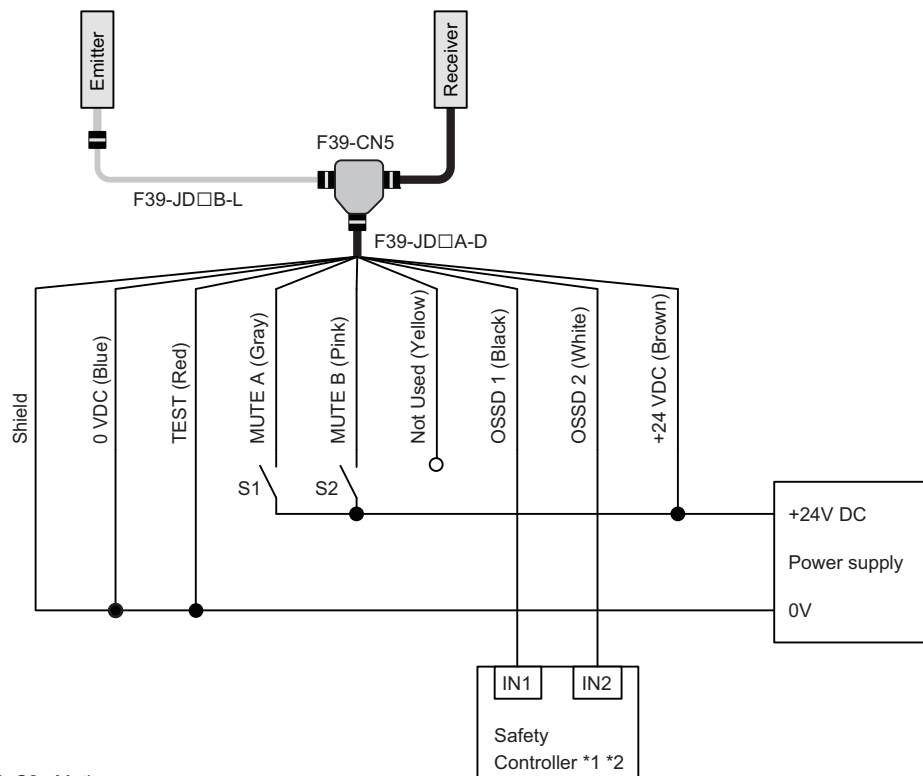

S1, S2 : Muting sensor

*1. Refer to 5-3. *Connectable Safety Control Units* for more information.

*2. The safety controller and the F3SG-RR must share the power supply or be connected to the common terminal of the power supply.

*3. The functions are configurable with Configuration Tool. Refer to *Safety Light Curtain Configuration Tool for Model F3SG (SD Manager 2) User's Manual* for more information on setting the functions by the Configuration Tool.

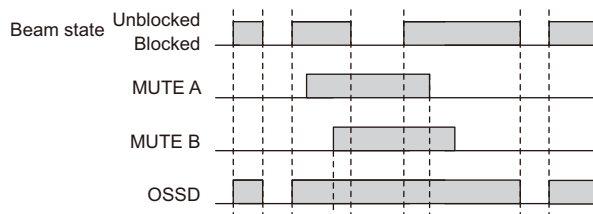

When using the Reduced Wiring Connector (F39-CN5), the following functions are not available.

- Manual Reset
 - External Device Monitoring
- CHECK!
- Auxiliary Output
 - Override

Make sure to keep the settings in the factory default.



The wiring example does not indicate functional earth. To use functional earth, wire an earth cable according to the example in 5-2-1-1. *Auto Reset Mode, EDM enabled and PNP Outputs*. Also refer to 4-5-4. *Functional Earth Connection* for more information.

CHECK!

5-2-2-3. Standard Muting Mode/Exit-Only Muting Mode with two Muting Sensors using PNP Outputs

The following is the example of External Device Monitoring disabled, Auto Reset Mode, PNP outputs and External Test in 24 V Active (used).

[Settings]

	Function
Receiver	EDM Disabled *5
	Auto Reset (factory default setting) *5
	PNP Output (factory default setting) *5
Emitter	External Test: 24 V Active (End Cap: Black) (factory default setting)

[Wiring Example]

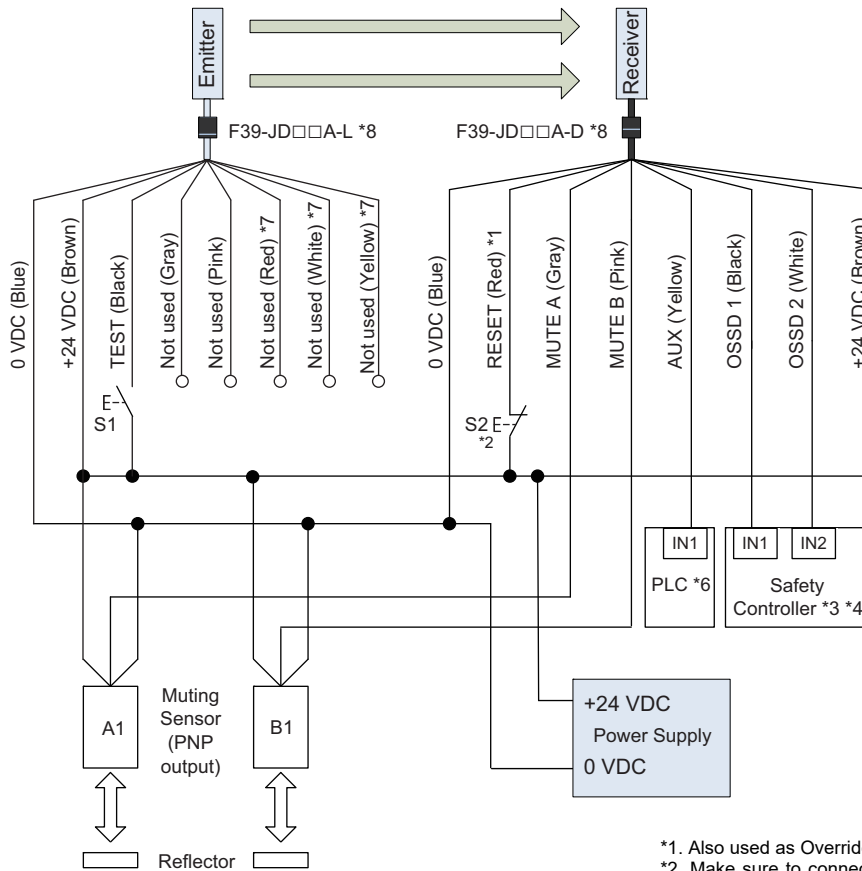

S1: Test Switch (Connect the line to 0 V if this switch is not required)
 S2: Lockout Reset Switch, Override Switch or Override Cancel Switch
 A1, B1: Muting sensor

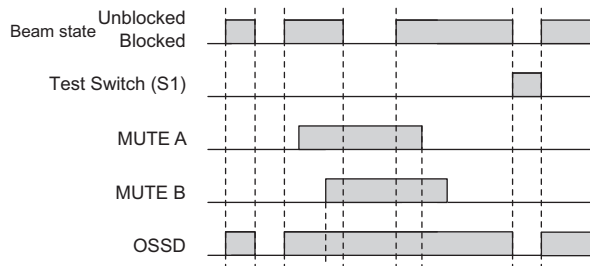

- *1. Also used as Override input line.
- *2. Make sure to connect an override cancel switch to the RESET line when using the override function. Otherwise the override state may not be released by the override cancel switch, resulting in serious injury.
- *3. Refer to 5-3. *Connectable Safety Control Units* for more information.
- *4. The safety controller and the F3SG-RR must share the power supply or be connected to the common terminal of the power supply.
- *5. The functions are configurable with Configuration Tool. Refer to *Safety Light Curtain Configuration Tool for Model F3SG (SD Manager 2) User's Manual* for more information on setting the functions by the Configuration Tool.
- *6. When connecting to the PLC, the output mode must be changed with the Configuration Tool according to your application.
- *7. The F39-JD□□RA-L Single-Ended Cable for Emitter (Oil-Resistant Cable) does not have the red, white and yellow wires.
- *8. For the F39-JD□□A-□ Single-Ended Cable, connect the shield line to 0 V.

 The wiring example does not indicate functional earth. To use functional earth, wire an earth cable according to the example in 5-2-1-1. *Auto Reset Mode, EDM enabled and PNP Outputs*. Also refer to 4-5-4. *Functional Earth Connection* for more information.

CHECK!

5-2-2-4. Standard Muting Mode with four Muting Sensors using PNP Outputs

The following is the example of External Device Monitoring disabled, Auto Reset Mode, PNP outputs and External Test in 24 V Active (used).

[Settings]

	Function
Receiver	EDM Disabled *5
	Auto Reset (factory default setting) *5
	PNP Output (factory default setting) *5
Emitter	External Test: 24 V Active (End Cap: Black) (factory default setting)

[Wiring Example]

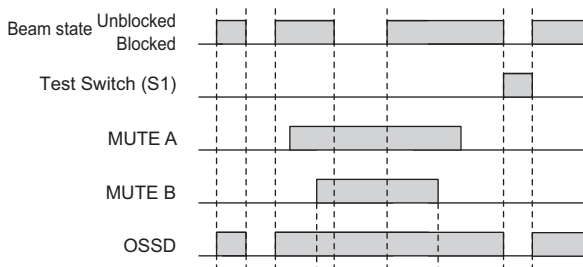
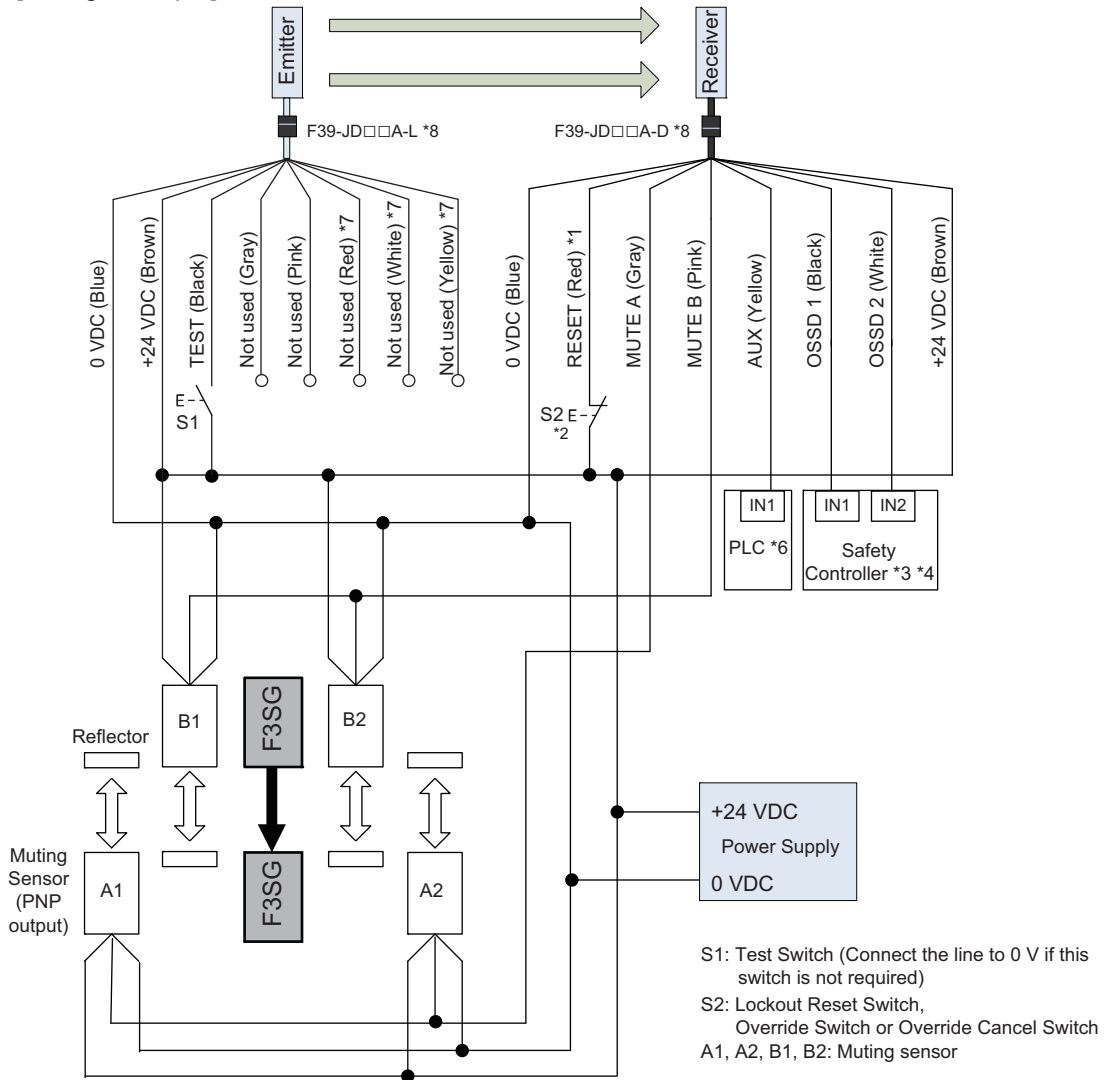

- *1. Also used as Override input line.
- *2. Make sure to connect an override cancel switch to the RESET line when using the override function. Otherwise the override state may not be released by the override cancel switch, resulting in serious injury.
- *3. Refer to 5-3. *Connectable Safety Control Units* for more information.
- *4. The safety controller and the F3SG-RR must share the power supply or be connected to the common terminal of the power supply.
- *5. The functions are configurable with Configuration Tool. Refer to *Safety Light Curtain Configuration Tool for Model F3SG (SD Manager 2) User's Manual* for more information on setting the functions by the Configuration Tool.
- *6. When connecting to the PLC, the output mode must be changed with the Configuration Tool according to your application.
- *7. The F39-JD□□RA-L Single-Ended Cable for Emitter (Oil-Resistant Cable) does not have the red, white and yellow wires.
- *8. For the F39-JD□□A-□Single-Ended Cable, connect the shield line to 0 V.



The wiring example does not indicate functional earth. To use functional earth, wire an earth cable according to the example in 5-2-1-1. *Auto Reset Mode, EDM enabled and PNP Outputs*. Also refer to 4-5-4. *Functional Earth Connection* for more information.

CHECK!

5-2-3. Standalone F3SG-RR using NPN Outputs

5-2-3-1. Auto Reset Mode, EDM enabled and NPN Outputs

The following is the example of Muting not used, External Device Monitoring enabled, Auto Reset Mode, NPN outputs and External Test in 0 V Active (not used).

[Settings]

	Function
Receiver	EDM Enabled (factory default setting) *1
	Auto Reset (factory default setting) *1
	NPN *1
Emitter	External Test: 0 V Active (End Cap: White)

[Wiring Example]

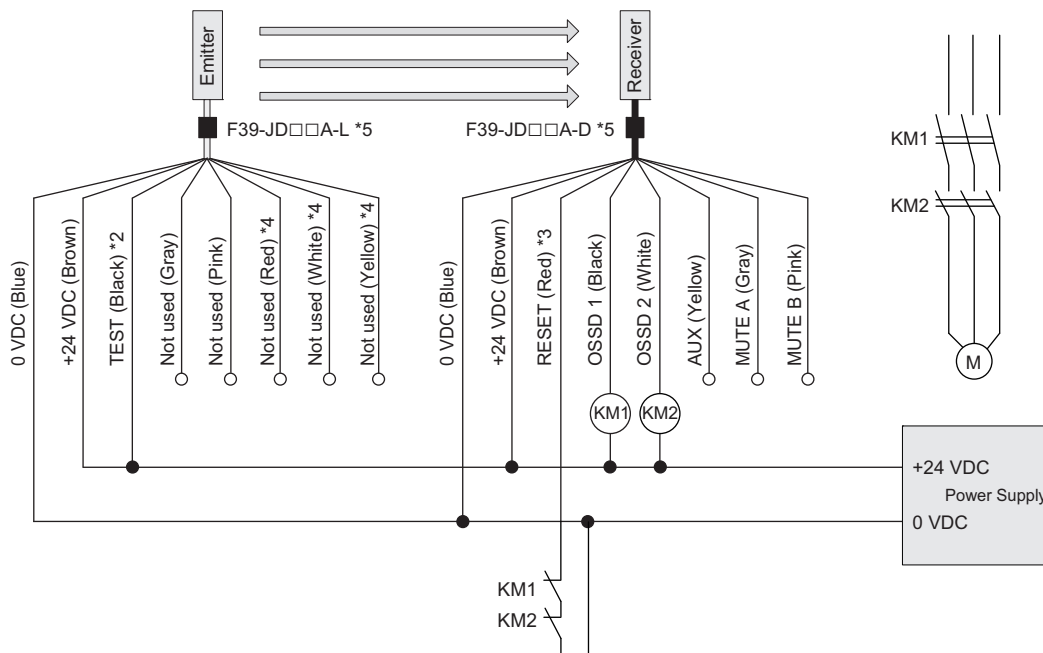

KM1, KM2: Safety relay with forcibly guided contacts (G7SA)
M: Motor

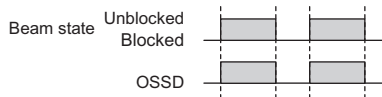

- *1. The functions are configurable with Configuration Tool. Refer to *Safety Light Curtain Configuration Tool for Model F3SG (SD Manager 2) User's Manual* for more information on setting the functions by the Configuration Tool.
- *2. Connect the line to 0 V via a test switch (NO contact) if External Test is used.
- *3. Also used as EDM line. Connect a lockout reset switch (NC contact) to this line in series with the KM1 and KM2 if Lockout Reset is used.
- *4. The F39-JD□□RA-L Single-Ended Cable for Emitter (Oil-Resistant Cable) does not have the red, white and yellow wires.
- *5. For the F39-JD□□A-□ Single-Ended Cable, connect the shield line to 0 V.

 The wiring example does not indicate functional earth. To use functional earth, wire an earth cable according to the example in 5-2-1-1. *Auto Reset Mode, EDM enabled and PNP Outputs*. Also refer to 4-5-4. *Functional Earth Connection* **CHECK!** for more information.

5-2-3-2. Manual Reset Mode, EDM disabled and NPN Outputs

The following is the example of Muting not used, External Device Monitoring disabled, Manual Reset Mode, NPN outputs and External Test in 0 V Active (used).

[Settings]

	Function
Receiver	EDM Disabled *1
	Manual Reset *1
	NPN *1
Emitter	External Test: 0 V Active (End Cap: White)

[Wiring Example]

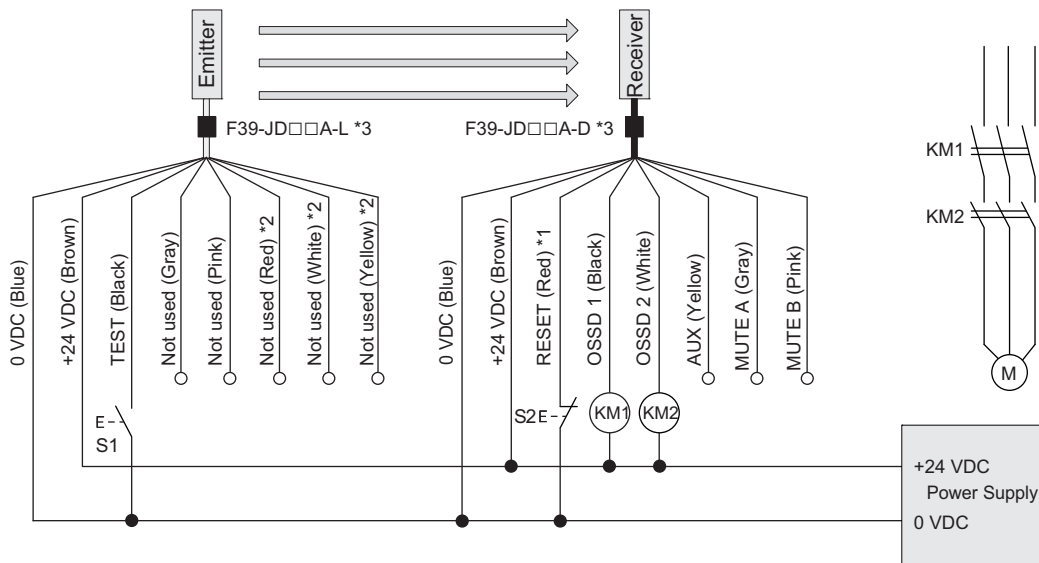

S1: Test Switch (Connect the line to 24 V if this switch is not required)
 S2: Lockout/Interlock Reset Switch
 KM1, KM2: Safety relay with forcibly guided contacts (G7SA)
 M: Motor

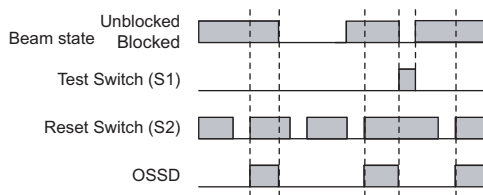

- *1. The functions are configurable with Configuration Tool. Refer to *Safety Light Curtain Configuration Tool for Model F3SG (SD Manager 2) User's Manual* for more information on setting the functions by the Configuration Tool.
- *2. The F39-JD□□RA-L Single-Ended Cable for Emitter (Oil-Resistant Cable) does not have the red, white and yellow wires.
- *3. For the F39-JD□□A-□ Single-Ended Cable, connect the shield line to 0 V.

The wiring example does not indicate functional earth. To use functional earth, wire an earth cable according to the example in 5-2-1-1. *Auto Reset Mode, EDM enabled and PNP Outputs*. Also refer to 4-5-4. *Functional Earth Connection* for more information.

CHECK!

5-2-3-3. Replacing the F3SJ-B Safety Light Curtain with F3SG-RR

The following is the example of External Device Monitoring enabled, Manual Reset Mode, NPN outputs and External Test in 0 V Active (used).

When replacing the F3SJ-B with F3SG-RR, change the wiring as shown below if using the Interlock/Lockout Reset function with the RESET line (yellow) of the F3SJ-B emitter.

[F3SJ-B Wiring Example]

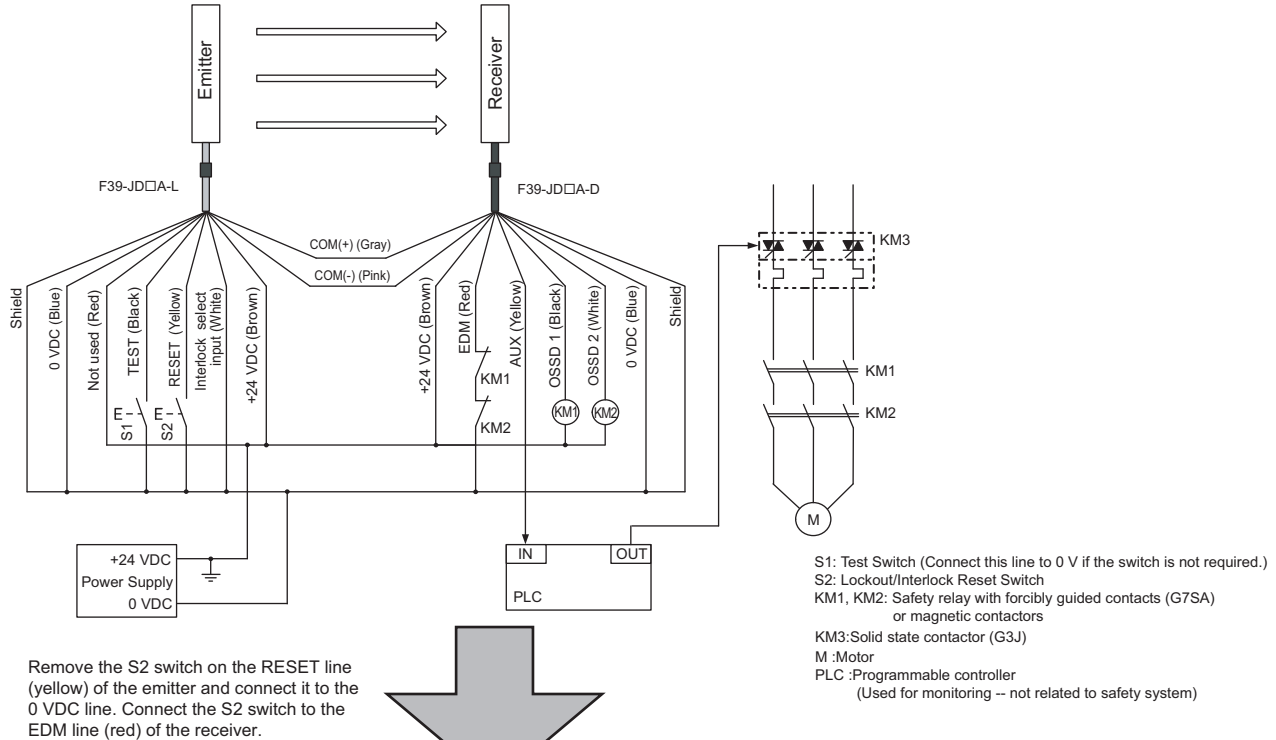

[Wiring Example to Replace with F3SG-RR]

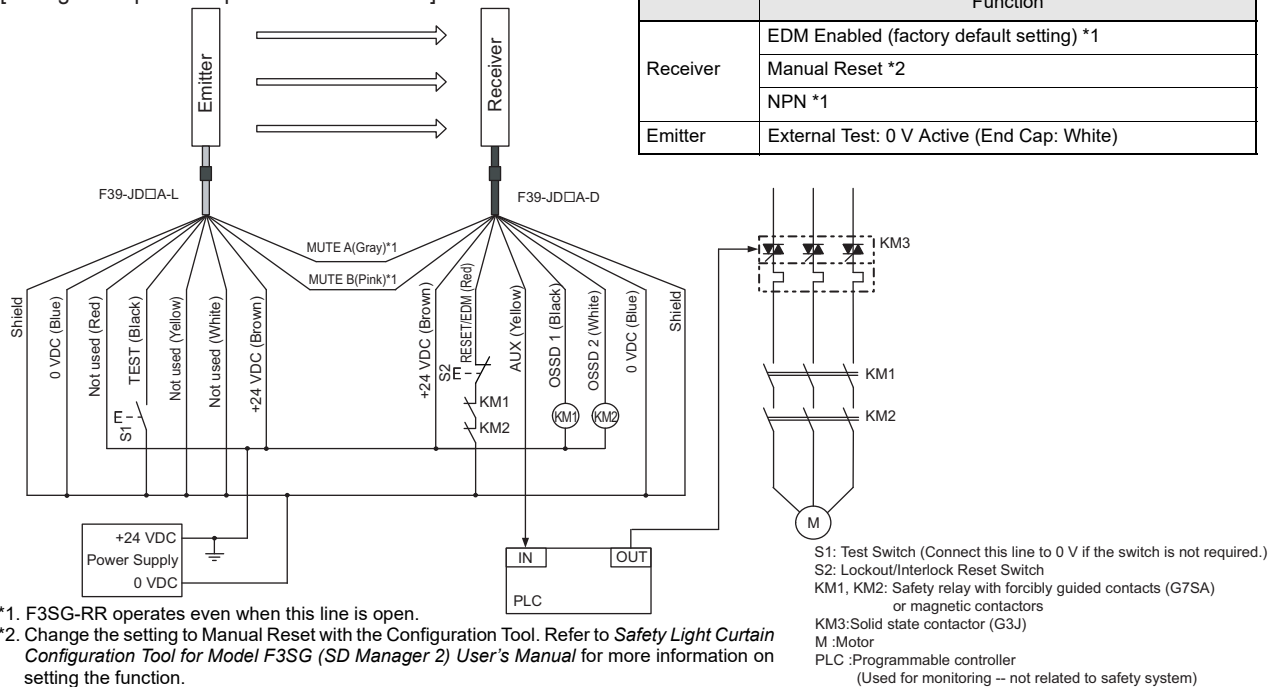

💡 Connect the RESET line (yellow) used for the F3SJ-B emitter to 0 VDC line directly. This connection is not needed when using the Auto Rest Mode.

CHECK!

💡 The wiring example does not indicate functional earth. To use functional earth, wire an earth cable according to the example in 5-2-1-1. *Auto Reset Mode, EDM enabled and PNP Outputs*. Also refer to 4-5-4. *Functional Earth Connection* for more information.

CHECK!

5-2-3-4. F3SG-RR with Reduced Wiring Connector and NPN Outputs

The following is the example of Muting not used, Auto Reset Mode, NPN outputs and External Test in 0 V Active (not used).

[Settings]

	Function
Receiver	Auto Reset (factory default setting) *1
	NPN *1
Emitter	External Test: 0 V Active (End Cap: White)

The reduced wiring system can be achieved by using the Reduced Wiring Cables (F39-JD□BA) and the Reduced Wiring Connector (F39-CN5).

[Wiring Example]

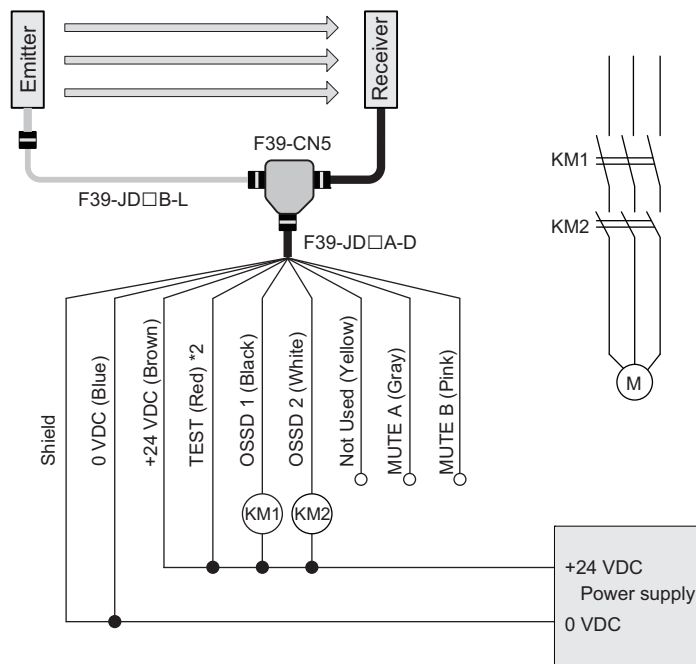

KM1, KM2: Safety relay with forcibly guided contacts (G7SA)
M: Motor

*1. The functions are configurable with Configuration Tool. Refer to *Safety Light Curtain Configuration Tool for Model F3SG (SD Manager 2) User's Manual* for more information on setting the functions by the Configuration Tool.

*2. Connect the line to 0 V via a test switch (NO contact) if External Test is used.

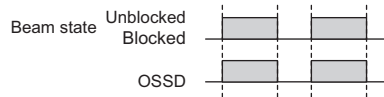

When using the Reduced Wiring Connector (F39-CN5), the following functions are not available.

- Manual Reset
- External Device Monitoring
- CHECK! - Auxiliary Output
- Override

Make sure to keep the settings in the factory default.



The wiring example does not indicate functional earth. To use functional earth, wire an earth cable according to the example in 5-2-1-1. *Auto Reset Mode, EDM enabled and PNP Outputs*. Also refer to 4-5-4. *Functional Earth Connection*

CHECK! for more information.

5-2-3-5. Pre-Reset Mode using NPN Output

The following is the example of External Device Monitoring enabled, Pre-Reset mode, NPN output and External Test in 0 V Active (used).

[Settings]

	Function
Receiver	EDM Enabled (factory default setting) *2
	Pre-Reset *2
	NPN *2
Emitter	External Test: 0 V Active (End Cap: White)

[Wiring Example]

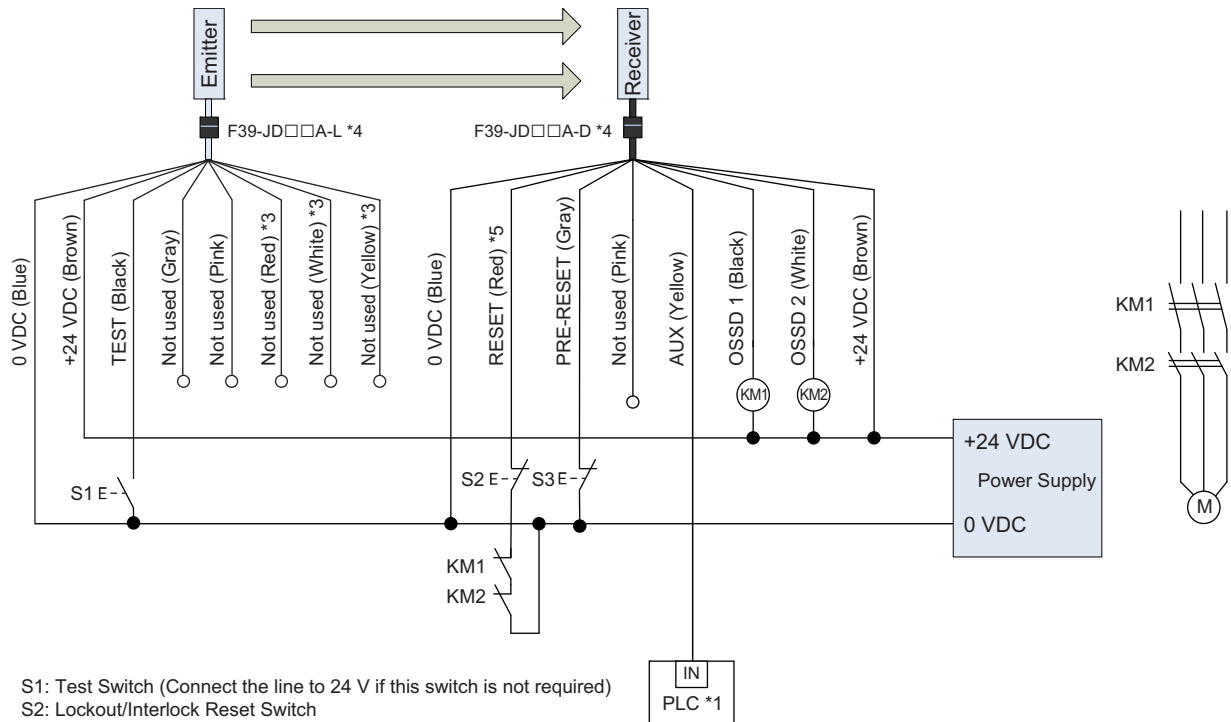

- S1: Test Switch (Connect the line to 24 V if this switch is not required)
- S2: Lockout/Interlock Reset Switch
- S3: Pre-Reset Switch
- KM1, KM2: External device feedback
- M: Motor
- PLC: Programmable controller
(Used for monitoring only. NOT related to safety system.)

*1. When connecting to the PLC, the output mode must be changed with the Configuration Tool according to your application.
 *2. The functions are configurable with Configuration Tool. Refer to *Safety Light Curtain Configuration Tool for Model F3SG (SD Manager 2) User's Manual* for more information on setting the functions by the Configuration Tool.
 *3. The F39-JD□□RA-L Single-Ended Cable for Emitter (Oil-Resistant Cable) does not have the red, white and yellow wires.
 *4. For the F39-JD□□A-□ Single-Ended Cable, connect the shield line to 0 V.
 *5. Also used as EDM line.

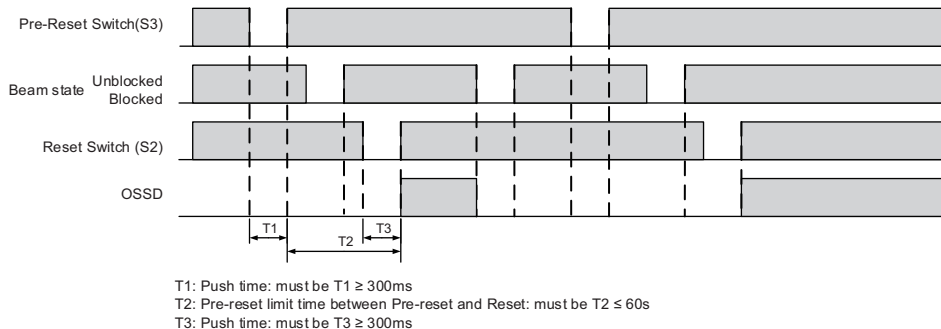

The wiring example does not indicate functional earth. To use functional earth, wire an earth cable according to the example in 5-2-1-1. *Auto Reset Mode, EDM enabled and PNP Outputs*. Also refer to 4-5-4. *Functional Earth Connection* for more information.

CHECK!

5-2-4. Muting using NPN Outputs

5-2-4-1. Standard Muting Mode/Exit-Only Muting Mode using NPN Outputs

The following is the example of External Device Monitoring enabled, Auto Reset Mode, NPN outputs and External Test in 0 V Active (used).

[Settings]

	Function
Receiver	EDM Enabled (factory default setting) *3
	Auto Reset (factory default setting) *3
	NPN *3
Emitter	External Test: 0 V Active (End Cap: White)

[Wiring Example]

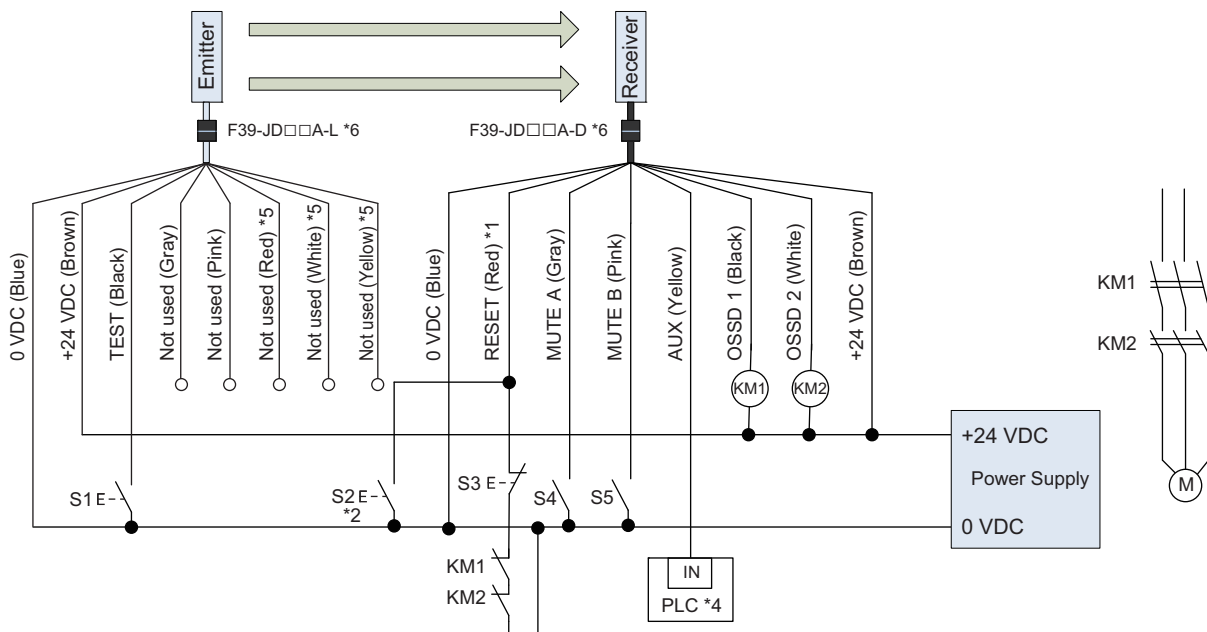

S1: Test Switch (Connect the line to 24 V if this switch is not required)

S2: Override Cancel Switch

S3: Lockout Reset Switch or Override Switch

S4, S5: Muting sensor

KM1, KM2: Safety relay with forcibly guided contacts (G7SA) or magnetic contactor

M: Motor

*1. Also used as Override input or EDM line.

*2. Make sure to connect an override cancel switch to the RESET line when using the override function. Otherwise the override state may not be released by the override cancel switch, resulting in serious injury.

*3. The functions are configurable with Configuration Tool. Refer to *Safety Light Curtain Configuration Tool for Model F3SG (SD Manager 2) User's Manual* for more information on setting the functions by the Configuration Tool.

*4. When connecting to the PLC, the output mode must be changed with the Configuration Tool according to your application.

*5. The F39-JD□□RA-L Single-Ended Cable for Emitter (Oil-Resistant Cable) does not have the red, white and yellow wires.

*6. For the F39-JD□□A-□ Single-Ended Cable, connect the shield line to 0 V.

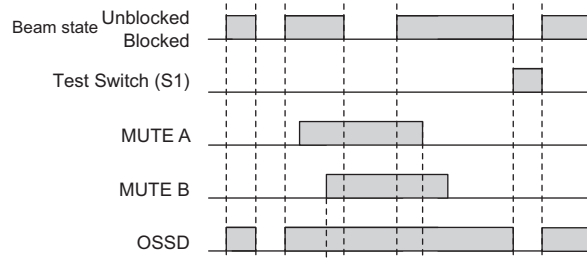

The wiring example does not indicate functional earth. To use functional earth, wire an earth cable according to the example in 5-2-1-1. *Auto Reset Mode, EDM enabled and PNP Outputs*. Also refer to 4-5-4. *Functional Earth Connection* for more information.

CHECK!

5-2-4-2. Standard Muting Mode/Exit-Only Muting Mode with two Muting Sensors using NPN Outputs

The following is the example of External Device Monitoring enabled, Auto Reset Mode, NPN outputs and External Test in 0 V Active (used).

[Settings]

	Function
Receiver	EDM Enabled (factory default setting) *3
	Auto Reset (factory default setting) *3
	NPN *3
Emitter	External Test: 0 V Active (End Cap: White)

[Wiring Example]

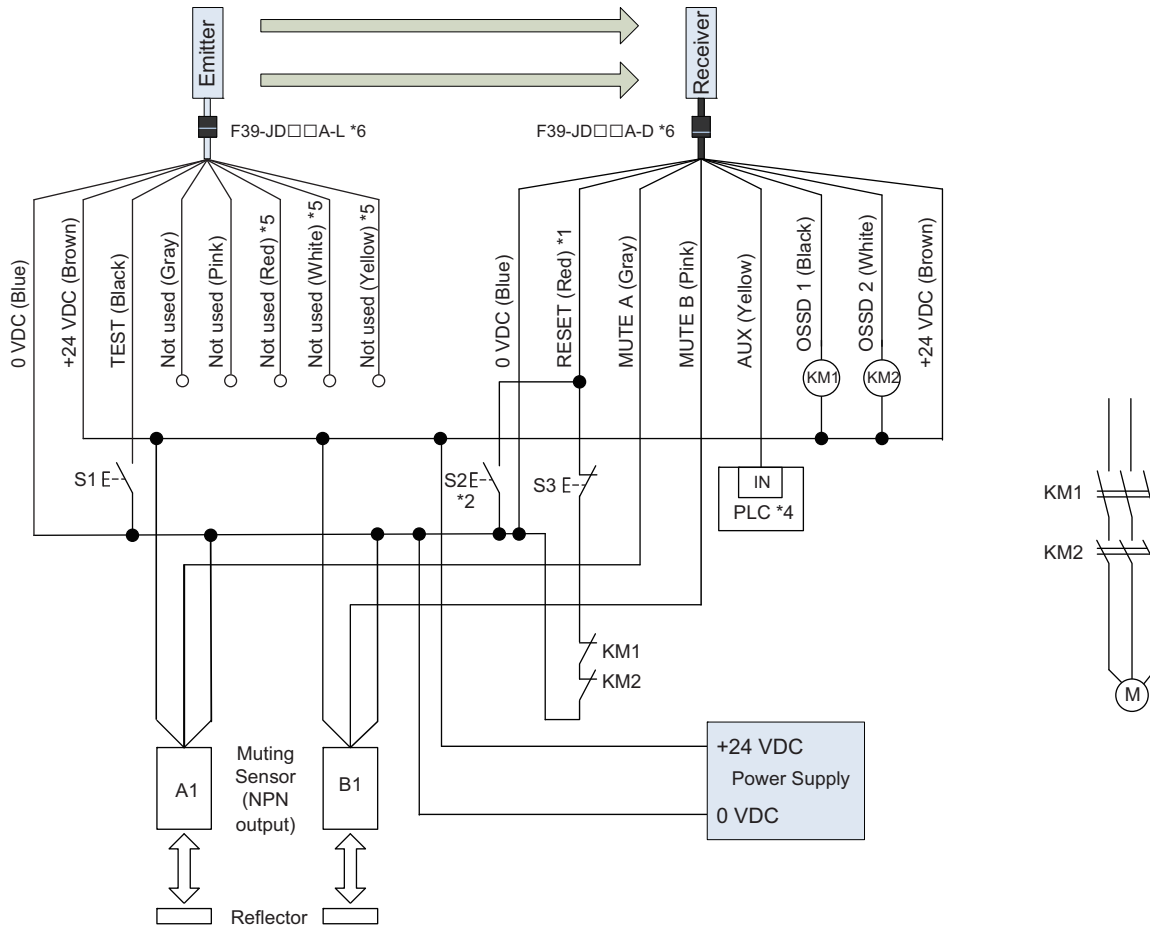

- S1: Test Switch (Connect the line to 24 V if this switch is not required)
- S2: Override Cancel Switch
- S3: Lockout Reset Switch or Override Switch
- KM1, KM2: Safety relay with forcibly guided contacts (G7SA) or magnetic contactor
- M: Motor
- A1, B1: Muting sensor

- *1. Also used as Override input or EDM line.
- *2. Make sure to connect an override cancel switch to the Reset line when using the override function. Otherwise the override state may not be released by the override cancel switch, resulting in serious injury.
- *3. The functions are configurable with Configuration Tool. Refer to *Safety Light Curtain Configuration Tool for Model F3SG (SD Manager 2) User's Manual* for more information on setting the functions by the Configuration Tool.
- *4. When connecting to the PLC, the output mode must be changed with the Configuration Tool according to your application.
- *5. The F39-JD□□RA-L Single-Ended Cable for Emitter (Oil-Resistant Cable) does not have the red, white and yellow wires.
- *6. For the F39-JD□□A-□ Single-Ended Cable, connect the shield line to 0 V.

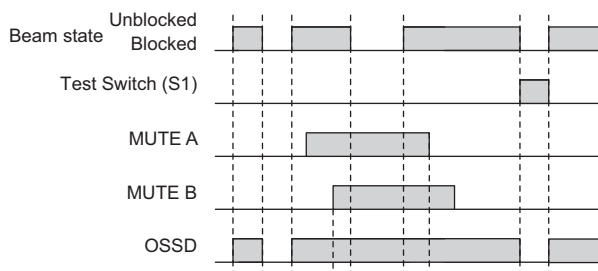

 The wiring example does not indicate functional earth. To use functional earth, wire an earth cable according to the example in 5-2-1-1. *Auto Reset Mode, EDM enabled and PNP Outputs*. Also refer to 4-5-4. *Functional Earth Connection* for more information.

CHECK!

5-2-4-3. Standard Muting Mode with four Muting Sensors using NPN Outputs

The following is the example of External Device Monitoring enabled, Auto Reset Mode, NPN outputs and External Test in 0 V Active (used).

[Settings]

	Function
Receiver	EDM Enabled (factory default setting) *3
	Auto Reset (factory default setting) *3
	NPN *3
Emitter	External Test: 0 V Active (End Cap: White)

[Wiring Example]

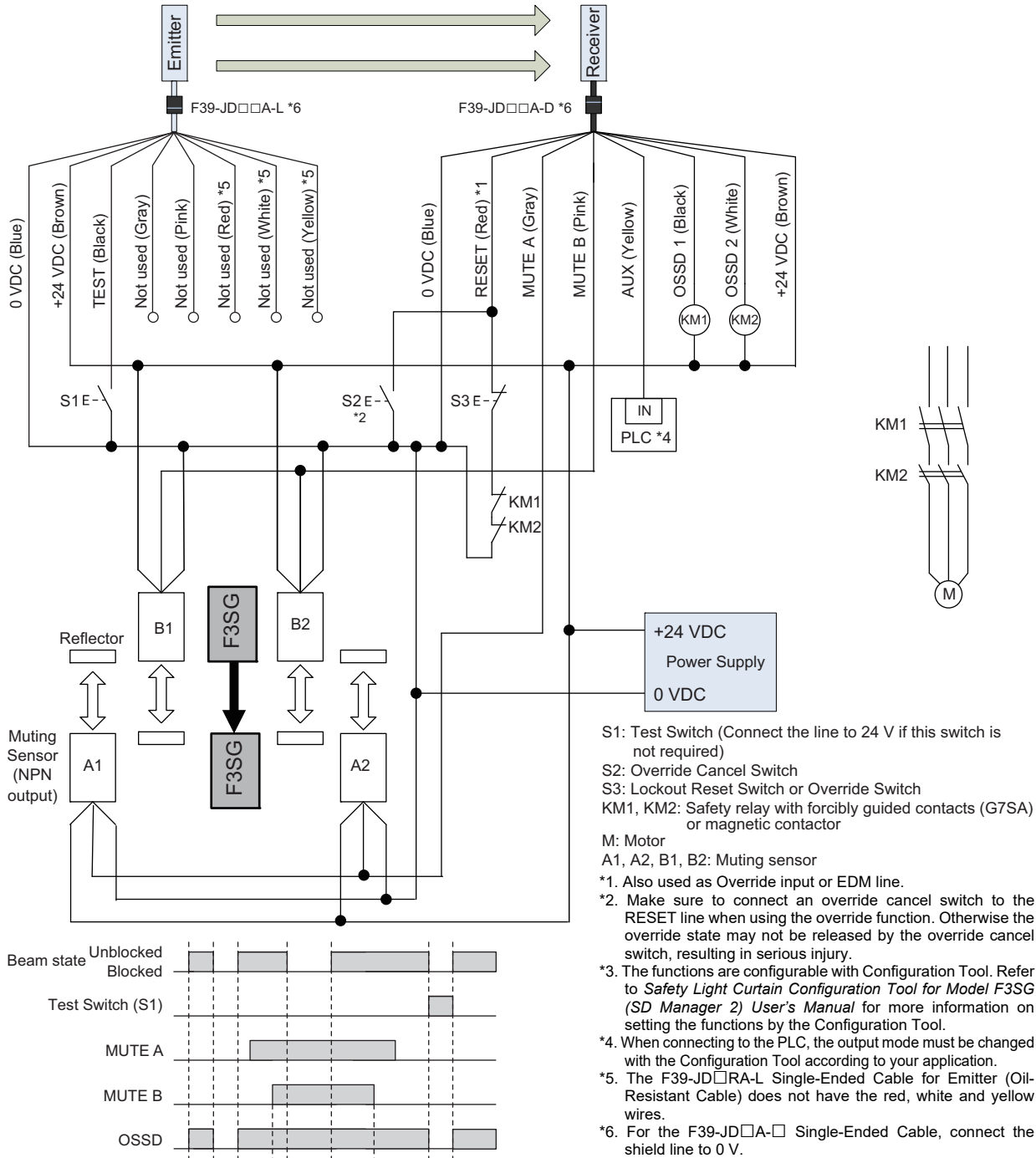

The wiring example does not indicate functional earth. To use functional earth, wire an earth cable according to the example in 5-2-1-1. *Auto Reset Mode, EDM enabled and PNP Outputs*. Also refer to 4-5-4. *Functional Earth Connection* for more information.

CHECK!

5-3. Connectable Safety Control Units

The F3SG-RR with PNP output can be connected to the safety control units listed in the table below.

Connectable Safety Control Units (PNP output)		
G9SA-301	G9SX-AD322-T	G9SP-N10S
G9SA-321-T□	G9SX-ADA222-T	G9SP-N10D
G9SA-501	G9SX-BC202	G9SP-N20S
G9SB-200-B	G9SX-GS226-T15	NE0A-SCPU01
G9SB-200-D		NE1A-SCPU01
G9SB-301-B		NE1A-SCPU02
G9SB-301-D		DST1-ID12SL-1
G9SE-201		DST1-MD16SL-1
G9SE-401		DST1-MRD08SL-1
G9SE-221-T□		NX-SIH400
		NX-SID800
		F3SP-T01

The F3SG-RR with NPN output can be connected to the safety control unit listed in the table below.

Connectable Safety Control Units (NPN output)
G9SA-301-P

Chapter 6 Checklists

6-1. Pre-Operation Checklists	180
6-2. Maintenance Checklists	183

6-1. Pre-Operation Checklists



WARNING

Make sure Responsible Person tests the operation of the F3SG-RR after installation to verify that the F3SG-RR operates as intended. Make sure to stop the machine until the test is complete. Unintended function settings may cause a person to go undetected, resulting in serious injury.



After installation, the highest level administrator must use the following checklist to verify the operation, placing a check mark in each of the boxes.

6-1-1. Checklists

6-1-1-1. Installation Condition Check

- The machine itself does not prevent the operation of safety functions such as stopping.
- The hazardous part of a machine cannot be reached without passing through the detection zone of the F3SG-RR.
- The system is configured so that the F3SG-RR can always detect a worker who is working in the hazardous zone.
- The interlock reset switch is installed in a location that provides a clear view of the entire hazardous zone and it cannot be activated from within the hazardous zone.
- The pre-reset switch is installed in a location inside the hazardous zone and where it cannot be operated from outside the hazardous zone.
- Safety distance has been calculated. Calculated distance: $S = (\quad)\text{mm}$
- Safety distance has been calculated with larger object resolution when floating blanking or reduced resolution function is used.
Calculated distance: $S = (\quad)\text{mm}$
- The actual distance is equal to or greater than the calculated distance. Actual distance = $(\quad)\text{mm}$
- Reflective surfaces are not installed in prohibited zones.
- Not installed in a retro-reflective configuration.
- When muting function is used, a muting sensor must be installed so that muting state should not occur when a human body enters a detection zone of F3SG-RR by mistake.
- When muting function is used, a muting sensor must be installed so that muting state should not occur when a human body enters a hazardous zone of a machine.
- When muting function is used, muting state can be checked from where a worker operates or adjust the machine.
- A muting sensor consists of 2 independent devices.
- It is not used in flammable or explosive atmosphere.

6-1-1-2. Wiring Check Before Power Is Turned ON

- When the power supply unit is connected to multiple devices, the power supply unit must have tolerance against total rated current of the devices.
- The power supply unit is a 24 VDC unit that conforms to the EMC Directive, Low-voltage Directive, and output holding time specifications.
- The power supply polarity is not connected in reverse.
- Emitter/receiver cables are properly connected to the respective emitters/receivers.
- Double insulation is used between I/O lines and the hazard potential (commercial power supplies, etc.).
- When using PNP output, the outputs are not short-circuited to +24 VDC line. When using NPN output, the outputs are not short-circuited to 0 V line.
- When using PNP output, loads are not connected to +24 VDC line. When using NPN output, loads are not connected to 0 V line.
- All lines are not connected to commercial power source.
- F3SG-R's power supply connector and series connection connector must not be attached upside down.
- Model of emitter and receiver must be the same.

- When 2 or more F3SG-RR systems are used, they are in cascade connection or prevented from mutual interference with each other.
- On a secondary sensor farthest from its power supply, either of the following is attached:
 - End Cap
 - Lamp (F39-LP and F39-BTLP, sold separately)
 - Bluetooth® Communication Unit (F39-BT, sold separately)
- Neither connector, cap, or bracket must be loose.
- Auxiliary output must not be used as safety output.
- When using PNP output, +24 VDC line of the power supply must not be grounded. When using NPN output, 0 VDC line of the power supply must not be grounded.
- Wiring must not be bent, cracked, nor damaged.

6-1-1-3. Operation Check While the Machine Is Stopped

- The test rod is not deformed.

The object resolution may vary depending on the models of the F3SG-RR and settings of floating blanking function or reduced resolution function. Use a test rod with an appropriate diameter for inspection. A test rod is not included in the F3SG-RR product package.
- The sensor must detect a test rod wherever it is in the detection zone. In other words, when a test rod is inserted into the detection zone, the Stable-state indicator turns OFF and the ON/OFF indicator turns red.

When fixed blanking function is used, you must ensure that all blanked zones in the detection zone are covered by a hard barrier guard and there must be no zone in the detection zone where the test rod goes undetected.

To check detection, move the test rod as shown in the diagram below.

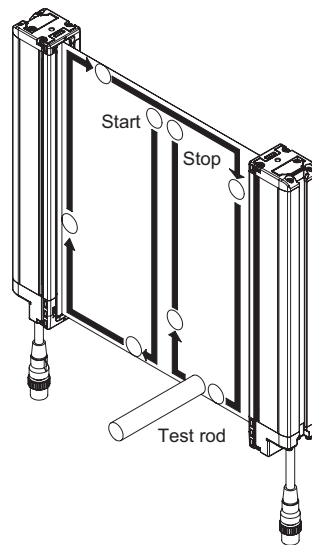

- When the external test function is used:
 - When 24 V Active is enabled, the ON/OFF indicator turns red when the TEST line is short-circuited to 9 V to V_s .
 - When 0 V Active is enabled, the ON/OFF indicator turns red when the TEST line is short-circuited to 0 to 3 V.
- When the external device monitoring function is used:
 - When the RESET line is open the ON/OFF indicator remains red regardless of the beam state of the F3SG-RR.
- When the start interlock function is used:
 - When the F3SG-RR is turned ON and the F3SG-RR is unblocked, the ON/OFF indicator remains red. The RESET input turns the ON/OFF indicator to green.
- When the restart interlock function is used:
 - When the ON/OFF indicator is green and the F3SG-RR is blocked and then returned to unblocked state, the ON/OFF indicator remains red. The RESET input turns the ON/OFF indicator to green.
- When muting function is used, minimum muting time limit required must be set.
- When muting function's operation mode is exit-only muting mode, minimum muting end wait time required must be set.

- Under muting state, a signal that indicates muting state must be output from the Auxiliary Output.
- When override function is used, minimum override time limit required must be set.
- Under override state, a signal that indicates override state must be output from the Auxiliary Output.

6-1-1-4. Checking that Hazardous Parts Stop While the Machine Operates

- The hazardous parts stop immediately when a test rod is inserted into the detection zone at 3 positions: "directly in front of the emitter", "directly in front of the receiver", and "between the emitter and receiver". (Use the appropriate test rod.)
- The hazardous parts remain stopped as long as the test rod is in the detection zone.
- The hazardous parts stop when the power of the F3SG-RR is turned OFF.
- The actual response time of the whole machine is equal to or less than the calculated value.

6-2. Maintenance Checklists

WARNING

Perform daily and 6-month inspection for the F3SG-RR. Otherwise, the system may fail to work properly, resulting in serious injury.



Do not try to disassemble, repair, or modify this product. Doing so may cause the safety functions to stop working properly.



To ensure safety, keep a record of the inspection results.

When the user is a different person from those who installed or designed the system, he/she must be properly trained for maintenance.

6-2-1. Checklists

6-2-1-1. Inspection at Startup and When Changing Operators

- There is no approach route other than through the detection zone of the F3SG-RR.
- Part of the operator's body always remains in the detection zone of the F3SG-RR when working around the machine's hazardous part.
- The actual safety distance is equal to or greater than the calculated value.
- There must be no dirt on or damage to the optical surface of the F3SG-RR.
- When 24 V Active is enabled, ON/OFF indicator turns red when the TEST line is short-circuited to 9 V to Vs. When 0 V Active is enabled, ON/OFF indicator turns red when the TEST line is short-circuited to 0 to 3 V.
- When muting function is used, muting lamp must not be clear due to dirt or degradation.
- The test rod is not deformed.
- When the start interlock function is used:
 - When the F3SG-RR is turned ON and the F3SG-RR is unblocked, the ON/OFF indicator remains red. The RESET input turns the ON/OFF indicator to green.
- When the restart interlock function is used:
 - When the ON/OFF indicator is green and the F3SG-RR is blocked and then returned to unblocked state, the ON/OFF indicator remains red. The RESET input turns the ON/OFF indicator to green.
- When the power of the F3SG-RR is turned ON while nothing is in the detection zone, it must operate as follows:
 - If start interlock is not used: The Power indicator and ON/OFF indicator turn green within 2 seconds after the F3SG-RR is turned ON.
 - If start interlock is used: The Power indicator turns green and the ON/OFF indicator turns red within 2 seconds after the F3SG-RR is turned ON.
- Nothing should exist in the detection zone and the Stable-state indicator must turn ON at power on.

- The test rod is detected when it is moved around in the detection zone as shown in the diagram below. In other words, when a test rod is inserted into the detection zone, the Stable-state indicator turns OFF and the ON/OFF indicator turns red.
- When fixed blanking function is used, you must ensure that all blanked zones in the detection zone are covered by a hard barrier guard and there must be no zone in the detection zone where the test rod goes undetected.
- The object resolution may vary depending on the models of the F3SG-RR and settings of floating blanking function or reduced resolution function. Use a test rod with an appropriate diameter for inspection. A test rod is not included in the F3SG-RR product package.

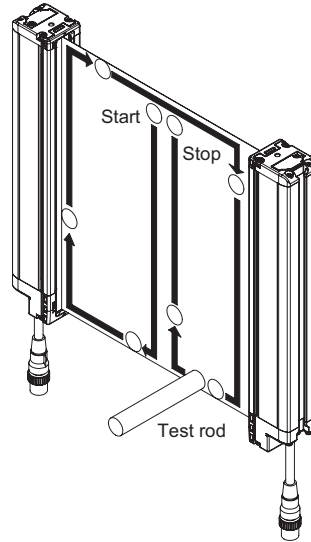

- When muting function is used, installation condition of muting sensor must not be changed.
- When muting function is used, muting status can be checked from where a worker operates or adjust the machine.
- Neither connector, cap, or bracket must be loose.

6-2-1-2. Checking that Hazardous Parts Stop While the Machine Operates

- The hazardous parts are movable when nothing is in the detection zone.
- The hazardous parts stop immediately when a test rod is inserted into the detection zone at 3 positions: "directly in front of the emitter", "directly in front of the receiver", and "between the emitter and receiver". (Use the appropriate test rod.)
- The hazardous parts remain stopped as long as the test rod is in the detection zone.
- The hazardous parts stop when the power of the F3SG-RR is turned OFF while nothing is in the detection zone.

6-2-1-3. Items to Inspect Every 6 Months or When Machine Settings Are Changed

In addition to inspection item at operation start, following items must also be verified.

- The outputs of the F3SG-RR and the machine are properly wired.
- The total number of times that the control relays/contactors have switched is significantly lower than their design lives.
- There is no ambient light.
- Safety distance has been calculated with changed object resolution when the setting of the floating blanking or reduced resolution function is changed.
Calculated distance: $S = (\quad)\text{mm}$
- When muting function setting is changed, a muting sensor must be installed so that muting state should not occur when a human body enters a detection zone of F3SG-RR by mistake.
- When muting function setting is changed, a muting sensor must be installed so that muting state should not occur when a human body enters a hazardous zone of a machine.
- When muting function setting is changed, a muting sensor must consist of 2 independent devices.
- When the configuration of the cascade connection is changed, either of the following is attached on a secondary sensor farthest from its power supply:

- End Cap
 - Lamp (F39-LP and F39-BTLP, sold separately)
 - Bluetooth® Communication Unit (F39-BT, sold separately)
- When using PNP output, +24 VDC line of the power supply must not be grounded. When using NPN output, 0 VDC line of the power supply must not be grounded.
- Wiring must not be bent, cracked, nor damaged.

Chapter 7 Appendix

7-1. Troubleshooting	188
7-1-1. Lockout State	189
7-1-2. Warning	193
7-2. Optional Accessories(Sold Separately)	196
7-3. Glossary	202
7-4. Revision History	206

7-1. Troubleshooting

<Emitter>

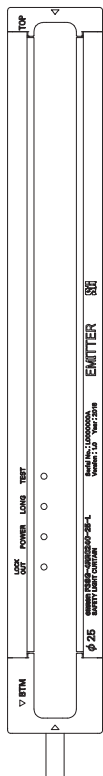

- 1. Test indicator (Green)
- 2. Operating range indicator (Green)
- 3. Power indicator (Green)
- 4. Lockout indicator (Red)

<Receiver>

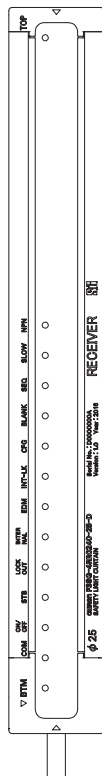

- 1. Top-beam-state indicator (Blue)
- 2. PNP/NPN mode indicator (Green)
- 3. Response time indicator (Green)
- 4. Sequence error indicator (Yellow)
- 5. Blanking indicator (Green)
- 6. Configuration indicator (Green)
- 7. Interlock indicator (Yellow)
- 8. External device monitoring indicator (Green)
- 9. Internal error indicator (Red)
- 10. Lockout indicator (Red)
- 11. Stable-state indicator (Green)
- 12. ON/OFF indicator (Green/Red)
- 13. Communication indicator (Green)
- 14. Bottom-beam-state indicator (Blue)

LED Blinking Pattern:

The timing chart below shows the blinking frequency of the LED blinking patterns (blinking once through seven times) described in the following pages.

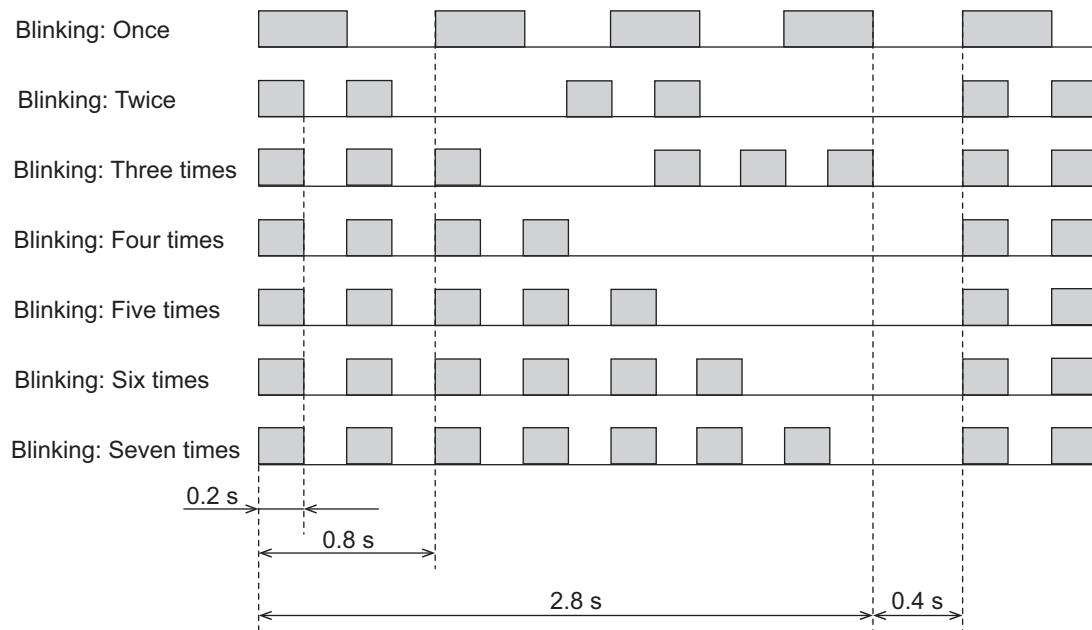

You can check error and warning logs by the Maintenance Information function of the Configuration Tool.



Refer to *Safety Light Curtain Configuration Tool for Model F3SG (SD Manager 2) User's Manual* for more information on checking error and warning logs by the Configuration Tool.

7-1-1. Lockout State

7-1-1-1. Description

If F3SG-RR detects any failure, it keeps safety output OFF and transitions to the Lockout state. Under lockout state, the Lockout indicators blink or are ON and other indicators blink based on the failure. Solve the problems based on the table below.

Eliminate the cause of the problem. Then turn the power ON again or reset the Lockout state by providing a reset input to restart the F3SG-RR.

7-1-1-2. Troubleshooting





















Identify an error according to the combination of the indicators when the error occurs. See the following troubleshooting tables to take measures.



<Indicator status at lockout: Receiver>

Combination of Indicators and Error Description

[Error Description]

LOCKOUT Blinking Once	TOP 	 Cap error Other sensor error
	BLANK 	 Blanking monitoring error
	CFG 	 Cascading configuration error
	EDM 	 External device monitoring error
	INTERNAL 	 Internal error
	ON OFF 	 Safety output error
	COM 	 Communication error
	BTM 	 Scan code setting error
LOCKOUT Blinking Twice	ON OFF 	 Safety output error due to power supply voltage or noise
	COM 	 Communication error due to power supply voltage or noise
	INTERNAL 	 Internal error due to power supply voltage or noise







 TOP, CFG, LOCKOUT, STB and ON/OFF indicators on the receiver of the F3SG-RR blink when the F3SG-RR is in Setting mode. The blinking patterns are Blinking Once or Blinking Twice, depending on the access level.







CHECK! Refer to *Safety Light Curtain Configuration Tool for Model F3SG (SD Manager 2) User's Manual* for more information on the statuses of the LED indicators in the Setting mode.

<Indicator status at lockout: Emitter>

Combination of Indicators and Error Description

[Error Description]

LOCKOUT Blinking Once	LONG 	 Scan code setting error
	POWER 	 Other sensor error Cascading configuration error Internal error Communication error
LOCKOUT Blinking Twice	POWER 	 Internal or Communication error due to noise

Description	Error code	Cause and measures
Cap error	4F	A cap may be detached. Attach the cap properly.
Other sensor error	38	Other sensor being cascaded caused an error. Check the indicator of the sensor.
Blanking monitoring error	EC	<p>An error is detected by the fixed blanking monitoring function or the floating blanking monitoring function. See Chapter 2 "Fixed Blanking" or "Floating Blanking" to solve the problem.</p> <p> 2-14. Fixed Blanking</p> <p> 2-15. Floating Blanking</p>
Cascading configuration error	39, 3A, 3B	The cascading cable may be short-circuited, broken, or disconnected. Check that the cascading cable should be tightly connected. If the cascading cable is broken, replace it.
		The number of connected sensors or beams may have exceeded the maximum value due to cascading. Check the configuration.
External device monitoring error	52	Relay may be welded. Replace the relay.
		The relay and the Reset line may not be properly wired. Check the wiring with the relay.  Chapter 4 Wiring/Installation
		The relay response time may be exceeding the allowable delay time. Change the allowable delay time or replace the relay with one that has an appropriate response time.  2-10. External Device Monitoring (EDM)  Chapter 4 Wiring/Installation
Safety output error	60, 6B, 6C	<p>Safety output lines may be short-circuited to each other or another signal line may be short-circuited to the safety output line. Wire the safety output lines properly.</p> <p> Chapter 4 Wiring/Installation</p>
Communication error	30, 31, 32	The communication line or other wiring may be broken or short-circuited. Check the cables for cascading or extension cables.
		<p>If the wiring is extended with cables other than specified, the cables used for extension may not have performance equivalent or greater than the specified cables. Use cables with the same performance or more than the specified cables.</p> <p> Chapter 4 Wiring/Installation</p>
Scan code setting error	E7, E8	A scan code setting may have been changed during operation. Check if there is any change to the scan code setting.

Description	Error code	Cause and measures
Safety output error due to power supply voltage or noise	19	<p>The power supply voltage may have dropped temporarily when the F3SG-RR is in operation. Check for temporary power supply voltage drop (by about 12 VDC) by the influence of the inductive load, etc.</p> <p>If the exclusive power supply is not used, check the power consumption of other connected devices for enough capacity.</p> <p>Power supply voltage may be outside the rated range. Connect the F3SG-RR to a 24 VDC±20% power supply voltage.</p> <p>Voltage fluctuation may have occurred due to insufficient power supply capacity. Replace the power supply with one that has a larger capacity.</p> <p>Instantaneous break or instantaneous stop may have occurred due to power sharing with other devices. Do not share the power supply with other devices. Connect the F3SG-RR to a power supply that is dedicated to electro-sensitive protective devices for electro-sensitive protective equipment such as the F3SG-RR, safety controller, etc.</p>
	1A	<p>Effect of noise may be excessive.</p> <p>If other devices using the same power supply generate noise, do not share the same power supply with other devices, and use a separate power supply exclusively for the safety components.</p> <p>The inductive noise tends to be induced especially if the power supply line of the machine guarded and the power supply line of the F3SG-RR are arranged in parallel. Arrange the exclusive power supply near the F3SG-RR or lay the power supply line of the F3SG-RR away from the power supply line of the machine guarded.</p> <p>If the power supply for the F3SG-RR is located near the power supply of the machine guarded and it uses the same ground, it is subject to the influence of common mode noise from the ground. Separate the grounding point or use it as the exclusive ground.</p> <p> 4-5-4. Functional Earth Connection</p>
Communication error due to power supply voltage or noise	19	<p>The power supply voltage may have dropped temporarily when the F3SG-RR is in operation. Check for temporary power supply voltage drop (by about 12 VDC) by the influence of the inductive load, etc.</p> <p>If the exclusive power supply is not used, check the power consumption of other connected devices for enough capacity.</p>
	1A	<p>Communication error may have occurred due to noise. Check the noise level in the environment.</p>
Internal error due to power supply voltage or noise	19, 1A	<p>The internal circuitry may be defective due to power supply voltage or noise. Check the noise level in the environment. Make sure that the power supply voltage is 24 VDC±20%. If the indicator still shows this error, replace the F3SG-RR.</p>
Internal or communication error due to noise	--	<p>The internal circuitry may be defective due to noise. Check the noise level in the environment.</p>
		<p>Communication error may have occurred due to noise. Check the noise level in the environment.</p>
Internal error	Error code other than those above	<p>An error may have occurred in the internal circuit. Replace the F3SG-RR.</p>

7-1-2. Warning

7-1-2-1. Description



If an error is detected that prevents the F3SG-RR to continue normal operation, the STB or SEQ indicator blinks to notify warning information according to the error. The F3SG-RR continues normal operation. In the Auto Reset mode, the F3SG-RR automatically recovers from the warning status when the cause of the error is solved. In the Manual Reset mode, the F3SG-RR keeps the safety outputs in the OFF state. A reset signal is required to release the Interlock state in this mode.

7-1-2-2. Troubleshooting

Identify an error according to the combination of the indicators when the error occurs. See the following troubleshooting tables to take measures.





<Indicator status at warning: Receiver>

Combination of Indicators and Error Description	[Warning Description]
LOCKOUT  STB 	Malfunction due to ambient light or vibration
SEQ  *1	Muting sequence error or Interlock sequence error







*1 There are several illumination patterns to identify a faulty sequence.

<Indicator status at warning: Emitter>

None



Description	Warning code	Cause and measures
Malfunction due to ambient light or vibration	11	Malfunction may have occurred due to ambient light or instantaneous beam misalignment from vibration. Check the installation condition. Take necessary measures against mutual interference according to "4-1-4. Mutual Interference Prevention".  4-1-4. Mutual Interference Prevention
Muting sequence error	2C, 2D, 2F	Muting input may have been applied in the incorrect order. Check the pattern of illumination of the LED indicator to identify the cause.  7-1-2-3. Muting Sequence Error Indication
Interlock sequence error	--	An input related to interlock may have been applied in an incorrect sequence. Check the pattern of illumination of the LED indicator to identify the cause.  7-1-2-4. Interlock Sequence Error Indication
Low incident light level	12	The incident light level may be low due to dirty optical surface or misaligned beams caused by vibration. Clean the optical surface and check the alignment of the beams. Take necessary measures for this according to 4-4-4. Beam Alignment Procedure.

7-1-2-3. Muting Sequence Error Indication

Sequence error indicator	Cause and measures
 Blinking: Once	Power supply may have been turned ON with muting input A or B being ON. Check the condition of the muting sensors and light curtains.
	Muting input B may have been turned ON before muting input A was turned ON. Check the condition of the muting sensors.
	Muting input A and B may have been turned ON at the same time. •Check the arrangement of the muting sensors. •Check if the wiring of muting input A and B is short-circuited.
	Either muting input A or B may have been turned ON with the light curtain being blocked or in Interlock State. Check the condition of the light curtains.
 Blinking: Twice	Muting input B may have been turned ON within $T1min (= 0.1 s^{-1})$ after muting input A was turned ON. •Check that if the muting sensors are installed too close each other. •Check that if the speed of the workpiece is too fast. *1 Factory default setting
	It may have taken $T1max (= 4 s^{-1})$ or longer for muting input B to be turned ON after muting input A was turned ON. •Check that if the muting sensors are installed too far each other. •Check that if the speed of the workpiece is too slow. *1 Factory default setting
	The light curtain may have been blocked after muting input A was turned ON but before muting input B was turned ON. Check the condition of the light curtains.
 Blinking: Four times	The light curtain may have been blocked within 0.08 s after muting input A and B were normally turned ON. •Check that if the muting sensor and light curtain are installed too close each other. •Check that if the speed of the workpiece is too fast.
	Muting may have been released after the light curtain entered the muting state but before a workpiece blocked the light curtain. •Check that the workpiece still remains. •Check that the speed of the workpiece is too slow.
 Blinking: Five times	The light curtain entered the muting state, but muting may have then been released while a workpiece passes through the light curtain. •Check that the workpiece still remains. •Check that if the speed of the workpiece is too slow. •Check that the muting sensors have been installed upstream and downstream of the light curtain with the size of workpieces taken into account. (Using four muting sensors)
 Blinking: Six times	Muting may have been released with muting input A and B remained ON after a workpiece passed through the light curtain. •Check that the workpiece still remains. •Check that the speed of the workpiece is too slow.
 Blinking: Seven times	The next muting sequence may have started after muting was released but before the initial muting condition was established. •Check that if a next workpiece has not entered before the current workpiece passes through the light curtain. •Check that if the interval between workpieces are too narrow.

7-1-2-4. Interlock Sequence Error Indication

The following table is applied only when the pre-reset function is being enabled.

Sequence error indicator	Cause and measures
 Blinking: Once	The reset or pre-reset switch may have been pressed before the light curtain receives light. Check the reset input and pre-reset input wiring.
	The light curtain may have been interrupted or the pre-reset switch may have been pressed before the pre-reset switch is pressed. Check the light curtain status and pre-reset input wiring.
 Blinking: Twice	After the pre-reset switch was pressed, the pre-reset or reset switch may have been pressed before the light curtain is interrupted. Check the installation environment of the light curtain.
 Blinking: Three times	After the pre-reset switch was pressed and the light curtain was interrupted, the pre-reset switch may have been pressed before the reset switch is pressed. Check the pre-reset input wiring.
	After the pre-reset switch was pressed, a time period from interruption of the light curtain to the reset switch being pressed may have exceeded the allowable time. Check the installation environment of the light curtain as well as pre-reset and reset switches.
	The number of interruptions of the light curtain may have exceeded the allowable value after the pre-reset switch was pressed and before the reset switch is pressed. Check the installation environment of the light curtain.

7-1-3. Troubles Other Than in Lockout State

Shown below are actions to take when F3SG-RR does not work properly while no lockout occurred and no error is displayed.

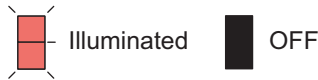

<Indicator status: Receiver>

Combination of Indicators and Error Description

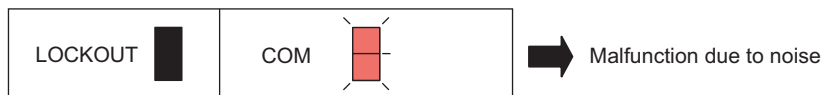

[Description]

<Indicator status: Emitter>



None

The COM indicator is illuminated with all beams of F3SG-RR blocked or light emission stopped.

Description	Cause and Measures
Malfunction due to noise	Effect of noise may be excessive. If other devices using the same power supply generate noise, do not share the same power supply with other devices, and use a separate power supply exclusively for the safety components. The inductive noise tends to be induced especially if the power supply line of the machine guarded and the power supply line of the F3SG-RR are arranged in parallel. Arrange the exclusive power supply near the F3SG-RR or lay the power supply line of the F3SG-RR away from the power supply line of the machine guarded. If the power supply for the F3SG-RR is located near the power supply of the machine guarded and it uses the same ground, it is subject to the influence of common mode noise from the ground. Separate the grounding point or use it as the exclusive ground.  4-5-4. Functional Earth Connection

7-2. Optional Accessories(Sold Separately)

Single-Ended Cable (Oil-Resistant Cable)

Appearance	Model	Cable length	Specifications
Emitter 	F39-JD3RA-L	3 m	Emitter cable (F39-JD□RA-L): M12 connector (8-pin), 5 wires Receiver cable (F39-JD□RA-D): M12 connector (8-pin), 8 wires IP67 and IP67G (JIS C 0920 Annex 1)* rated when mated. * F3SG-RR meets the degree of protection when it is correctly connected with the power cable. The degree of protection is not satisfied with the part where cable wires are uncovered.
	F39-JD7RA-L	7 m	
Receiver 	F39-JD3RA-D	3 m	
	F39-JD7RA-D	7 m	

Single-Ended Cable (2 cables per set, one for emitter and one for receiver)

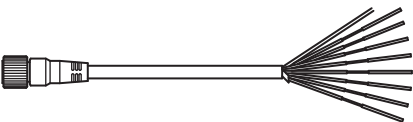
Appearance	Model	Cable length	Specifications
	F39-JD3A	3 m	M12 connector (8-pin), 8 wires + Shield wire IP67* rated when mated.
	F39-JD7A	7 m	
	F39-JD10A	10 m	
	F39-JD15A	15 m	
	F39-JD20A	20 m	

*When the accessory is used, protect it from cutting oil.

Double-Ended Cable (for extension) (2 cables per set, one for emitter and one for receiver)

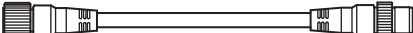
Appearance	Model	Cable length	Specifications
	F39-JDR5B	0.5 m	M12 connector (8-pin) on both ends IP67* rated when mated.
	F39-JD1B	1 m	
	F39-JD3B	3 m	
	F39-JD5B	5 m	
	F39-JD7B	7 m	
	F39-JD10B	10 m	
	F39-JD15B	15 m	
	F39-JD20B	20 m	

*When the accessory is used, protect it from cutting oil.

Reduced Wiring Connector

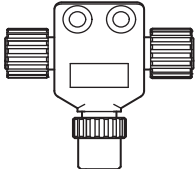
Appearance	Model	Remarks
	F39-CN5	IP67* rated when mated. Used for reduced wiring system. Use this connector in combination with Cables for Reduced Wiring.

*When the accessory is used, protect it from cutting oil.

Cable for Reduced Wiring*1 (2 cables per set, one for emitter and one for receiver)

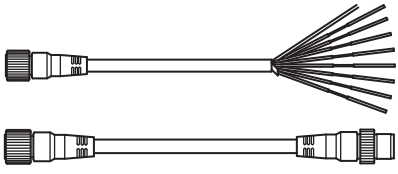
Appearance	Model	Cable length	Remarks
 <p>IP67*2 rated when mated</p>	F39-JD0303BA	Emitter : 3 m Receiver : 3 m	Double-Ended Cable : F39-JD3B-L Single-Ended Cable : F39-JD3A-D
	F39-JD0307BA	Emitter : 3 m Receiver : 7 m	Double-Ended Cable : F39-JD3B-L Single-Ended Cable : F39-JD7A-D
	F39-JD0310BA	Emitter : 3 m Receiver : 10 m	Double-Ended Cable : F39-JD3B-L Single-Ended Cable : F39-JD10A-D
	F39-JD0503BA	Emitter : 5 m Receiver : 3 m	Double-Ended Cable : F39-JD5B-L Single-Ended Cable : F39-JD3A-D
	F39-JD0507BA	Emitter : 5 m Receiver : 7 m	Double-Ended Cable : F39-JD5B-L Single-Ended Cable : F39-JD7A-D
	F39-JD0510BA	Emitter : 5 m Receiver : 10 m	Double-Ended Cable : F39-JD5B-L Single-Ended Cable : F39-JD10A-D
	F39-JD1003BA	Emitter : 10 m Receiver : 3 m	Double-Ended Cable : F39-JD10B-L Single-Ended Cable : F39-JD3A-D
	F39-JD1007BA	Emitter : 10 m Receiver : 7 m	Double-Ended Cable : F39-JD10B-L Single-Ended Cable : F39-JD7A-D
	F39-JD1010BA	Emitter : 10 m Receiver : 10 m	Double-Ended Cable : F39-JD10B-L Single-Ended Cable : F39-JD10A-D

Note: A combination of emitter and receiver cables of other lengths than the above is also available. For details, contact your Omron representative.

*1. Double-Ended Cable for emitter and Single-End Cable for receiver.

*2. When the accessory is used, protect it from cutting oil.

Cascading Cable (2 cables per set, one for emitter and one for receiver)

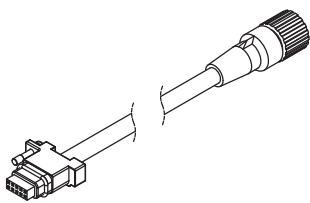
Appearance	Model	Cable length	Specifications
	F39-JGR2WTS	0.2 m	Cap (8-pin), M12 connector (8-pin) IP67* rated when mated.

*When the accessory is used, protect it from cutting oil.

Interface Unit*

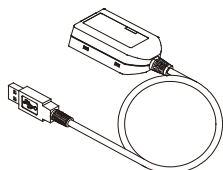
Appearance	Model	Remarks
	F39-GIF-1	Used to connect an F3SG-RR receiver to a USB port of a PC. Accessories: F39-CN1 Branch Connector (1), Connector Cap (1), 2-m Dedicated Cable (1), Instruction Sheet

*When the accessory is used, protect it from cutting oil.

Bluetooth® Communication Unit

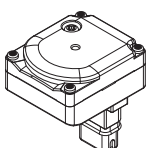
Appearance	Model	Remarks
	F39-BT	Used for the receiver. IP67* rated. Material: PBT

*When the accessory is used, protect it from cutting oil.

Lamp and Bluetooth® Communication Unit

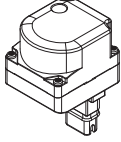
Appearance	Model	Remarks
	F39-BTLP	Used for the receiver. IP67* rated. Material: PC (Lighting element) PBT (Other body parts)

*When the accessory is used, protect it from cutting oil.

Lamp

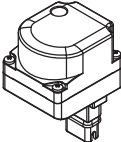
Appearance	Model	Remarks
	F39-LP	Used for the receiver. IP67* rated. Material: PC (Lighting element) PBT (Other body parts)

*When the accessory is used, protect it from cutting oil.

End Cap

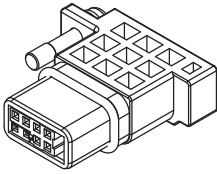
Appearance	Model	Remarks
	F39-CNM	Housing color: Black For both emitter and receiver (The End Cap can be purchased if lost.) IP67 rated when mated*1 *2

*1 This accessory can also be used for F3SG-RA.

*2. When the accessory is used, protect it from cutting oil.

Laser Alignment Kit*

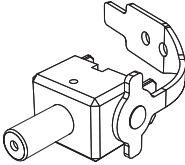
Appearance	Model	Application	Remarks
	F39-PTG	You can attach this to F3SG-RR. The laser light assists coarse beam alignment.	Red semiconductor laser (wavelength 650 nm, 1 mW max., JIS Class 2, IEC Class 2, FDA Class II)

*When the accessory is used, protect it from cutting oil.

Free-Location Bracket (Also used as Intermediate Bracket)

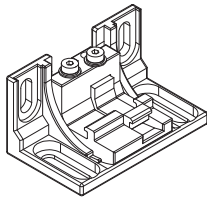
Appearance	Model	Application	Remarks
	F39-LGRA	Beam alignment after mounting possible. The angle adjustment range is $\pm 15^\circ$. Side mounting and backside mounting possible.	2 brackets per set Protective height and number of brackets required: 0240 to 1200 mm: 2 sets 1280 to 2080 mm: 3 sets

Top/Bottom Bracket

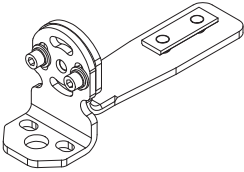
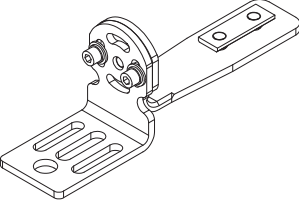
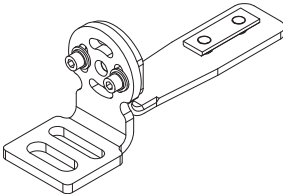
Appearance	Model	Application	Remarks
	F39-LGRTB	Use this bracket at the top and bottom positions of the F3SG-RR. Beam alignment after mounting possible. The angle adjustment range is $\pm 22.5^\circ$. Side mounting and backside mounting possible.	4 brackets per set. When it is necessary to use it with another bracket, only the combination with the Intermediate Bracket is possible.
	F39-LGRTB-2	Use this bracket at the top and bottom positions of the F3SG-RR. The angle adjustment range is $\pm 22.5^\circ$. Side mounting and backside mounting possible. The part of this bracket to contact with a wall surface has a different shape from the F39-LGRTB Top/Bottom Bracket.	Protective height and number of brackets required: 1120 to 1920 mm: 1 set of Top/Bottom Bracket and 1 set of Intermediate Bracket 1040 mm or less: Intermediate Bracket is not required.
	F39-LGRTB-3	Use this bracket when replacing an existing safety light curtain with F3SG-RR.	

Test Rod

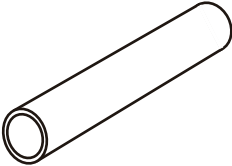
Appearance	Model	Diameter
	F39-TRD14 F39-TRD25	14 mm dia., Length: 250 mm, Material: ABS resin 25 mm dia., Length: 250 mm, Material: ABS resin



To check operation before use, purchase and use the test rod.

CHECK!

Control Unit

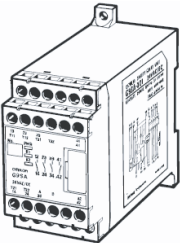
Appearance	Model	Output	Remarks
	G9SA-301 G9SA-321-T075 G9SA-321-T15 G9SA-321-T30	Safety output (relay): NO contact x 3 Auxiliary output (relay): NC contact x 1	<ul style="list-style-type: none"> An F39-JD□A Single-Ended Cable is required. An F3SG-RR with PNP output can be connected.
	G9SA-501	Safety output (relay): NO contact x 5 Auxiliary output (relay): NC contact x 1	

Control Unit

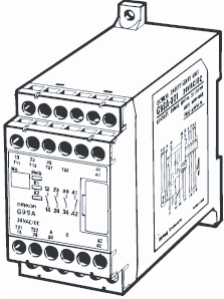
Appearance	Model	Output	Remarks
	G9SA-301-P	Safety output (relay): NO contact x 3 Auxiliary output (relay): NC contact x 1	<ul style="list-style-type: none"> • An F39-JD□A Single Ended-Cable is required. • An F3SG-RR with NPN Output can be connected.

Control Unit

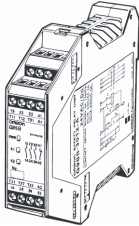
Appearance	Model	Output	Remarks
	G9SB-301-B	Safety output (relay): NO contact x 3 Auxiliary output (relay): NC contact x 1 Auto reset	<ul style="list-style-type: none"> • An F39-JD□A Single-Ended Cable is required. • An F3SG-RR with PNP output can be connected.
	G9SB-301-D	Safety output (relay): NO contact x 3 Auxiliary output (relay): NC contact x 1 Manual reset	
	G9SB-200-B	Safety output (relay): NO contact x 2 Auto reset	
	G9SB-200-D	Safety output (relay): NO contact x 2 Manual reset	

Control Unit

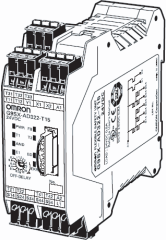
Appearance	Model	Output	Remarks
	G9SX-AD322-T15	Safety output (solid-state): source output (PNP) x 3 (instantaneous), source output (PNP) x 2 (OFF-delayed) Auxiliary output (solid-state): source output (PNP) x 2	<ul style="list-style-type: none"> • An F39-JD□A Single-Ended Cable is required. • An F3SG-RR with PNP output can be connected. • 16 patterns of OFF-delayed output for up to 15 seconds can be set. • The OFF-delayed output can be used as instantaneous output by setting it to 0 second. • Can be configured for partial control and total control. • Can be extended to connect a relay unit.

Control Unit

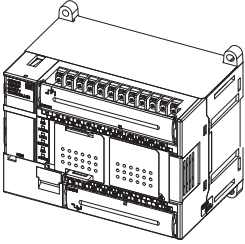
Appearance	Model	Output	Remarks
	G9SP-N10S	Safety output (solid-state): source output (PNP) x 4 Test output (solid-state): source output (PNP) x 4 Standard output (solid-state): source output (PNP) x 4	<ul style="list-style-type: none"> • An F39-JD□A Single-Ended Cable is required. • An F3SG-RR with PNP output can be connected.
	G9SP-N10D	Safety output (solid-state): source output (PNP) x 16 Test output (solid-state): source output (PNP) x 6	
	G9SP-N20S	Safety output (solid-state): source output (PNP) x 8 Test output (solid-state): source output (PNP) x 6	

Control Unit

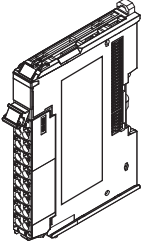
Appearance	Model	Application	Specifications
	NX-SIH400	Safety input (solid-state): sink input (PNP) x 4 Test output (solid-state): source output (PNP) x 2	<ul style="list-style-type: none"> • An F39-JD□A Single-Ended Cable is required. • An F3SG-RR with PNP output can be connected.
	NX-SID800	Safety input (solid-state): sink input (PNP) x 8 Test output (solid-state): source output (PNP) x 2	

Control Unit

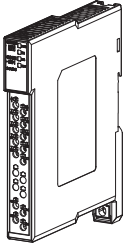
Appearance	Model	Application	Specifications
	G9SE-201	Safety output (relay): NO contact x 2 (instantaneous) Auxiliary output (solid-state): source output (PNP) x 1	<ul style="list-style-type: none"> • An F39-JD□A Single-Ended Cable is required. • An F3SG-RR with PNP output can be connected. • For G9SE-221-T□, 16 patterns of OFF-delayed output for up to 5 or 30 seconds can be set.
	G9SE-401	Safety output (relay): NO contact x 4 (instantaneous) Auxiliary output (solid-state): source output (PNP) x 1	
	G9SE-221-T□	Safety output (relay): NO contact x 2 (instantaneous), NO contact x 2 (OFF-delayed) Auxiliary output (solid-state): source output (PNP) x 1	

7-3. Glossary

	Term	Description
A	Accumulated load switching frequency	Total number of operations of a load to be connected to the F3SG-RR, from when the F3SG-RR is first energized until the present time.
	Allowable Beams	Dynamic Muting: Area(s) (or beam(s)) to be added in a Dynamic Muting zone, in order to prevent an accidental interruption of the F3SG-RR due to vibration.
		Fixed/Floating Blanking: Beam(s) in a Blanking zone, that are not monitored by the Blanking Monitoring function.
	Allowable delay time	The allowable amount of time difference from when the state of the Safety outputs changes until the state of an external relay changes. The F3SG-RR enters the Lockout state if this time is exceeded.
	Auto reset mode	Mode that disables Start Interlock and Restart Interlock. The Safety outputs are turned ON when no object is detected in the detection zone.
	Auxiliary output	Function to give output signal according to the settings. This must not be used for safety applications.
B	Blanking zone	Area in the detection zone of the F3SG-RR, where the Fixed Blanking or the Floating Blanking is enabled.
C	Configuration Tool	Setting tool that allows the user to make settings to the F3SG-RR with a PC.
D	Designated beam output	Function to signal the state of user-designated beam(s) to the Auxiliary output or Lamp. To use the function, target beam(s) must be designated.
	Designated beam output information	Information on the beam state of user-designated beam(s) to be signaled to the Auxiliary output or Lamp. To signal the information, the Designated beam output information must be assigned to an output destination.
	Dynamic muting	Function to configure a new muting zone after muting is enabled based on a result measuring a workpiece height for a certain period of time.
E	Effective aperture angle (EAA)	Range of angles in which the F3SG-RR can operate.
	Excess power-on time information	Information to be signaled to the Auxiliary output or Lamp when the power-on time exceeds the power-on time threshold value. To signal the information, the Power-On Time information must be assigned to an output destination.
	Exit-only muting delay time	Time difference from when the signal of Muting input A or B is turned OFF until the Muting state is cancelled.
	Exit-only muting mode	Muting mode to be used for such an application where objects move from the inside to the outside of the hazardous zone.
	External device monitoring function (EDM)	Function to monitor the operation of an NC contacts of external relays (or contactors) that control the hazardous zone of a machine, for any malfunctions such as welding.
	External test	Function that stops emission at a specified time to check that the Safety outputs are being properly turned OFF.
F	Fixed blanking	Function to disable part of the detection zone of the F3SG-RR and keep the Safety outputs in the ON state even if an object blocks the disabled detection zone.
	Fixed blanking monitoring function	Function to bring the F3SG-RR in the Lockout state (factory default setting) when part of the Fixed Blanking zone is unblocked.
	Floating blanking	Function to disable a specified number of beams in the detection zone of the F3SG-RR, and keep the Safety outputs in the ON state even if an object smaller than the dimension of the specified number of beams blocks the F3SG-RR.
	Floating blanking monitoring function	Function to bring the F3SG-RR in the Lockout state (factory default setting) if the number of blocked beams is smaller than specified.
I	Interlock	Function that keeps the Safety outputs in the OFF state until safety is ensured and a reset signal is received.
	Interlock Information	Information to be signaled to the Auxiliary output or Lamp when the F3SG-RR is in the Interlock is state. To signal the information, the Interlock information must be assigned to an output destination.

	Term	Description
	Interlock reset	Cancels the Interlock state.
	Inverted signal output mode	In this mode, the logic of the Auxiliary output signal is reversed.
L	Light level diagnosis information	Information to be signaled to the Auxiliary output or Lamp when the Safety output is in the ON state and when the incident light level is from 100% to 170% of the ON-threshold value for 10 seconds or more. To signal the information, the Light Level Diagnosis information must be assigned to an output destination.
	Light level monitoring	Function to read out the light level of incident light or ambient light on the F3SG-RR.
	Load switching frequency	Function to display the number of operations of a load to be connected to the F3SG-RR. The number is counted from when the number was last reset until the present time.
	Lockout	Function to keep the Safety outputs in the OFF state when an error is detected by the F3SG-RR.
	Lockout information	Information to be signaled to the Auxiliary output or Lamp when an error or lockout occurs. To signal the information, the Lockout information must be assigned to an output destination.
	Lower beam(s)	Beams located toward the Power Cable of the F3SG-RR.
M	Maintenance information	Function to read the maintenance information of the F3SG-RR and view it on a PC screen, with the Configuration Tool.
	Manual reset mode	Function to enable the Start Interlock and Restart Interlock. The Safety outputs are turned ON by applying a reset signal when there is no object in the detection zone.
	Maximum allowable muting signal interruption	Maximum duration of a signal interruption allowed in Muting inputs A and B.
	Muting	Function to temporarily disable the safety function of the F3SG-RR and keep the Safety outputs in the ON state even if the F3SG-RR is blocked.
	Muting end wait time	Time difference from when the F3SG-RR is unblocked until the Muting state is cancelled.
	Muting input time limit value (maximum)	Maximum time difference between Muting inputs A and B.
	Muting input time limit value (minimum)	Minimum time difference between Muting inputs A and B.
	Muting sensor	Input device, such as photoelectric sensor or proximity sensor, to give an input signal for notifying the start and end of the Muting function.
	Muting sequence error	An error that occurs when muting signal is not received in the correct order. The Safety outputs keep in the ON state unless the F3SG-RR is blocked.
	Muting time limit	The duration time of the Muting function. The Muting state is cancelled if it continues for longer than this time limit.
N	Number of floating beams	Number of beams to be configured in the Floating Blanking zone, for which the F3SG-RR does not transition to the Lockout state or Machine Stop state (Safety output OFF) even when blocked.
O	Object resolution (Detection capability)	Minimum size of an object that can be detected in the protective height of the F3SG-RR.
	Operating status monitoring	Function to read out the I/O data and status of functions of the F3SG-RR.
	Output operation mode	Information to be signaled to an output part (Safety output, Auxiliary output).
	Override	Function that forcibly turns the Safety outputs ON when the Muting is not working.
	Override input time limit (maximum)	Input time limit (maximum value) of the special sequence to activate the Override function.
	Override time limit	The duration time of the Override function. The Override state is cancelled if it continues for longer than this time limit.
P	PELV	Protected Extra Low Voltage. A grounded circuit separated by double insulation or equivalent from hazardous voltage. It does not generate voltage that exceeds ELV under normal conditions and under single-fault conditions. Normally, protection against direct contact is required.
	PNP/NPN Selection	Function to select the safety output type between PNP and NPN.

	Term	Description
	Position detection muting mode	Mode that enables the Muting function according to the position of a hazardous source such as a robot arm, using heterogeneous redundant inputs.
	Power-on time	Function to display the period of time when the F3SG-RR is energized, starting from when the power-on time was last reset until the present time.
	Power-on time reset	Function to reset the power-on time of the F3SG-RR to 0. In the case of cascade connection, the power-on time can be reset for each cascaded segment of the F3SG-RR.
	Power-on time threshold value	When the power-on time exceeds this value, an output is signaled to the Auxiliary output or Lamp. To signal the information, the Power-On Time information must be assigned to an output destination.
	Pre-Reset	One of the Interlock reset functions. Interlock state can be released only in the sequence that the operator operates the Pre-reset switch installed in the hazardous zone and leave the hazardous zone, and then operates the Reset switch outside the hazardous zone.
	Pre-Reset state	The F3SG-RR under this state is allowed to be blocked after the input of the Pre-Reset signal is ensured. When the number of times the F3SG-RR is blocked is set to infinite, the F3SG-RR stays in this state until the Reset input signal is received.
	Primary sensor	Name used for the F3SG-RR to be connected nearest the power supply, when in cascade connection.
R	Reduced resolution	Function to change the size of the object resolution so that an object of the size between 1 and 3 beams has no effect.
	Reset	Function to release the Interlock state or Lockout state.
	Response time adjustment	Function to change the response time so that the Safety outputs can hardly be turned OFF due to accidental interruption by an environmental factor.
	Response time from ON to OFF	Period of time from when the F3SG-RR is blocked until the Safety outputs are turned from ON to OFF.
	Restart interlock	Function to turn the Safety outputs to the OFF state when the F3SG-RR is blocked and keep this state until a reset signal is received.
S	Safety output (OSSD)	Output to be turned to the ON state when safety is ensured. This can be used for safety applications.
	Safety output information	Information to be signaled to the Auxiliary output or Lamp when the Safety outputs are in the ON state. To signal the information, the Safety output information must be assigned to an output destination.
	SD Manager 2	Setting software that is used as the Configuration Tool for the F3SG-RR. It allows the user to make settings to or monitor the operation of the F3SG-RR when the F3SG-RR is connected to the PC via the Interface Unit or Bluetooth® Communication Unit.
	Secondary sensor	Name used for other segments of F3SG-RR's than the primary sensor, when in cascade connection.
	SELV	Safety Extra Low Voltage. An ungrounded circuit separated by double insulation or equivalent from hazardous voltage. It does not generate voltage that exceeds ELV under normal conditions and under single-fault conditions. If the nominal voltage exceeds 25 VAC or 60 VDC, protection against direct contact is required.
	Setting recovery	Function to restore the factory settings of the F3SG-RR.
	Setting state	Status of the F3SG-RR when settings are being performed with the Configuration Tool. In this state, the Safety outputs are in the OFF state.
	Standard muting mode	Muting mode to be used for such an application where a muting sensor is positioned on both sides of the F3SG-RR.
	Start interlock	Function to turn the Safety outputs to the OFF state at power-on or recovery from power failure and keep this state until a reset signal is received.
T	Troubleshooting support signal	Information to be signaled to the Auxiliary output or Lamp when any one of a Muting Sequence Error, Interference/Vibration Information and Light Level Diagnosis Information signals is in the ON state. To signal the information, the Troubleshooting Support signal must be assigned to an output destination.
U	Upper beam(s)	Beams located toward the terminal of the F3SG-RR.

	Term	Description
V	Vs	Power supply voltage value in your usage environment.
W	Warning zone function	Function to configure part of the detection zone, in which the Safety outputs are not affected by the beam state. The blocked state of the Warning zone can be signaled to the Auxiliary output. This function must not be used for safety applications.
	Warning zone information	Information to be signaled to the Auxiliary output or Lamp when the Warning zone is blocked. To signal the information, the Warning Zone information must be assigned to an output destination.

7-4. Revision History

A manual revision code appears as a suffix to the manual number at the bottom of the front and back covers of this manual.

Z383-E1-04



Revision No.

Revision symbol	Revision date	Revisions
01	June 2017	First edition
02	January 2018	Minor corrections.
03	February, 2020	- Added or modified precautions in <i>Safety Precautions</i> . - Added more detailed descriptions of the override function.
04	July 2020	- Added the wiring examples of Auto Reset Mode (PNP/NPN). - Minor corrections.

OMRON Corporation Industrial Automation Company (Manufacturer)

Shiokoji Horikawa, Shimogyo-ku, Kyoto, 600-8530 JAPAN

Contact: www.ia.omron.com

Regional Headquarters

OMRON EUROPE B.V. (Importer in EU)

Wegalaan 67-69, 2132 JD Hoofddorp
The Netherlands
Tel: (31)2356-81-300/Fax: (31)2356-81-388

OMRON ASIA PACIFIC PTE. LTD.

No. 438A Alexandra Road # 05-05/08 (Lobby 2),
Alexandra Technopark,
Singapore 119967
Tel: (65) 6835-3011/Fax: (65) 6835-2711

OMRON ELECTRONICS LLC

2895 Greenspoint Parkway, Suite 200
Hoffman Estates, IL 60169 U.S.A.
Tel: (1) 847-843-7900/Fax: (1) 847-843-7787

OMRON (CHINA) CO., LTD.

Room 2211, Bank of China Tower,
200 Yin Cheng Zhong Road,
PuDong New Area, Shanghai, 200120, China
Tel: (86) 21-5037-2222/Fax: (86) 21-5037-2200

Authorized Distributor:

© OMRON Corporation 2017-2020 All Rights Reserved.
In the interest of product improvement,
specifications are subject to change without notice.

Cat. No. Z383-E1-04

Printed in Japan
0720(0617)